

# MAGIRUS EQUIPMENT



### Order placement equipment/loading/ consultation and distribution

Kindly place your order via phone or mail:

Phone: +49 731 408-2444

Mail: [magirus-equipment@ivecogroup.com](mailto:magirus-equipment@ivecogroup.com)

### Imprint

Edition: October 2023

Publisher: Magirus GmbH, Graf-Arco-Straße 30, D-89079 Ulm

Copyright: Magirus GmbH

Product portfolio non-binding, no liability accepted for mistakes and printing errors. Production subject to modification, especially regarding technical development and model changes. The images may show options that are subject to a charge. Original products may differ to images used in the catalogue, including colour deviation due to printing processes. Reproductions of any kind, including excerpts, are permissible only with written consent of Magirus GmbH Ulm.



Dear corporate customers,  
we are very excited to introduce to you our Magirus Equipment catalogue 2023/24, including several new products in the Magirus portfolio.

Fire fighters are impacted by ever tougher deployment scenarios. Hence, our new catalogue will also focus on deployment scenarios, e.g., fighting wildfires.

As always, we place great emphasis on offering you a portfolio of innovative and high-quality products. We therefore collaborate with selected suppliers, technology leaders in their field, to complement our portfolio.

One additional new product and an absolute highlight in our catalogue is the new firefighter helmet Magirus PROTECTUS P1. It revives the history of protective helmets already offered by Conrad-Dietrich Magirus after he founded C.D. Magirus Feuerwehr-Requisiten-Fabrik. You can find more information on PROTECTUS P1 on page 328 onwards.

We will continue to work on a host of other innovative and reliable products, to ensure maximum protection for firefighters during operations.









With our well-stocked warehouse at our headquarters in Ulm, we can guarantee seamless operations and quick turn-around time on your orders.

You are most welcome to submit your catalogue feedback through our points of contact. We are looking forward to your feedback and suggestions.

I hope you enjoy reading about our portfolio,



Frank Winkler  
Head Spare Parts management & Equipment

## CONTENTS

<b>FITTINGS &amp; HOSES</b> .....	<b>11</b>
Pressure hoses.....	12
Hoses.....	16
★ Hose integration system Easy-Fix .....	18
★ Hose carrying basket flexattack® „Waldbrand“ .....	20
Hose carrying baskets .....	21
Water-conducting fittings.....	24
★  Nozzle Magirus QC (Quick Connect) .....	34
★  Nozzles Magirus.....	35
Nozzles.....	37
Monitors .....	43
<b>FIRE EXTINGUISHING EQUIPMENT</b> .....	<b>47</b>
Stirrup & extinguishing backpack pumps and fire buckets .....	48
★ Vallfirest heavy-load carrying system .....	49
High pressure fire-extinguishing devices .....	50
★  Fire extinguisher Magirus .....	53
Fire extinguisher .....	56
★ Recover-E-Bag.....	59
Fire blankets.....	60
★ Fire blanket – passenger cars LEADER STOP.....	61
Foam fittings.....	62
Foaming agents .....	64
Transfer pumps.....	67
★  Our high-performance portable pump Magirus Fire 1500.....	68
★  Portable pumps .....	70
<b>TECHNICAL EQUIPMENT</b> .....	<b>73</b>
★  Magirus M-Eye Drone .....	74
Drone Magirus.....	76
<b>Generators</b>	
★  Generator MSE 14 Super Silent Plus .....	78
★  Generators Magirus .....	80
★ Generator Instagrid .....	81
Generators Endress.....	82
Generators Eisemann .....	85
Current-carrying equipment .....	88
<b>Lamps / Lighting</b>	
Hand lamps .....	94
Illuminators .....	105
Floodlights.....	107
Warning lights .....	111

	<b>Traffic safety</b>	
	Traffic cones & folding signs .....	116
	Warning & barrier material .....	118
★	Fan LEADER BatFan 3 Li+ .....	120
▲	Ventilation equipment Magirus .....	121
	Ventilation equipment .....	122
	Smoke shutters .....	127
	<b>Technical aid</b>	
	Hydraulic rescue equipment Lukas.....	128
	Hydraulic rescue equipment Weber.....	143
	Pneumatic rescue equipment Vetter.....	152
	Chainsaws Husqvarna .....	165
	Chainsaws Stihl .....	167
	Separating tools .....	174
	Plasma cutters .....	179
	Pumps Mast .....	180
	Vacuum cleaners.....	184
	<b>Rescue and Safety devices</b>	
	Ladders MUNK Rettungstechnik .....	186
	Rescue and working platforms .....	189
	Tool set Fall arrest/Pulley.....	191
▲	★ Stretcher rescue lanyard .....	193
	Ropes/ Rope bags.....	198
	Basket stretcher .....	200
	Jumping cushions .....	203
	<b>First-aid equipment</b>	
	Slings/Rescue blankets.....	204
	Stretchers .....	206
	Scoop stretchers & vacuum mattresses .....	207
	Spine boards .....	208
	First-aid boxes & backpacks.....	210
	Defibrillators .....	214
	Privacy screen/Sheltering tent .....	215
	Tools.....	218
	Tool boxes and cases.....	233
	Power tools .....	239
	Pull & lifting equipment .....	241
	Round & webbing slings.....	242
	Lashing straps.....	244
	Shackles .....	246
	Additional tools.....	247
	Snow chains .....	254

## CONTENTS

Reels/Roll containers	
One-person hose reels .....	255
Roll containers.....	261
 ★ Hygiene station MAGIRUS .....	263
<b>RESPIRATORY PROTECTION.....</b>	<b>265</b>
SCBA systems.....	266
Respiratory masks.....	271
Compressed-air cylinders .....	273
Respiratory monitoring.....	276
Escape & rescue devices.....	278
 ★ Thermal imaging cameras Magirus .....	280
Thermal imaging cameras.....	283
<b>ENVIRONMENTAL EQUIPMENT.....</b>	<b>287</b>
Gas detection technology.....	288
Dose rate meter.....	292
Hazardous materials fittings.....	293
Hazardous material pumps/Diaphragm pump.....	296
Additional hazardous material pumps.....	297
Containment tanks.....	298
Decontamination equipment .....	303
Binding agents.....	306
<b>PERSONAL PROTECTIVE EQUIPMENT (PPE).....</b>	<b>311</b>
Firefighter clothing.....	312
Protective clothing .....	321
Gloves.....	327
Boots .....	330
 ★ Firefighter helmet Magirus Protectus P1 .....	332
Helmets.....	338
Straps.....	340
<b>WILDLAND FIREFIGHTING EQUIPMENT .....</b>	<b>341</b>
Firefighter helmets .....	342
Protective equipment .....	347
Wildland fire gear .....	349
Wildland firefighting tools .....	354
★ Heliskid .....	356
Portable water tanks.....	358
Extinguishing module/portable pumps.....	359

<b>FIRE STATION EQUIPMENT.....</b>	<b>363</b>
★ Battery test & charging system .....	364
Charging devices.....	366
🚒 ★ Our Magirus ServiceLine portfolio .....	368
<b>MOUNTS/STORAGE.....</b>	<b>371</b>
Hose compartments.....	372
Storage for hose carrying baskets.....	374
Straps.....	375
Elastics .....	378
Small parts.....	379
Mounting brackets .....	382
Latches.....	383
Additional storage .....	384
Telescopic slide aluminium .....	390
Profile technology .....	392
<b>MERCHANDISE .....</b>	<b>393</b>
★ Model „Ulmer Leiter“ .....	394
Models .....	395
Children.....	397
Accessories .....	399
Books.....	403
Clothing.....	404
🚒 ★ Document case Magirus .....	405
<b>SPARE PARTS CONDITIONS OF SALE .....</b>	<b>406</b>
<b>INDEX A-Z .....</b>	<b>408</b>



# EVERY MAJOR DEVELOPMENT BEGINS WITH A VISION.

**Conrad Dietrich Magirus, Ulm fire-fighter, visionary, pioneer in fire-fighting technologies and trendsetting innovations – The man who still drives Magirus today.**

150 years ago Ulm fire-fighter Conrad Dietrich Magirus had only a single goal: Making life safer for himself and his comrades and making it easier to respond to emergencies. He found everything that had been developed for fire-fighting until then was not good enough. His personal on-the-job experience as a fire-fighter and commander taught him precisely where to look for potential improvements. Even his first invention revolutionised the world of fire-fighting: The "Ulm Ladder", a two-wheeled extension ladder which can be climbed when free-standing and moved when extended. In 1873 the ladder won the Gold Medal at the Vienna World's Fair. Soon hardly a fire brigade anywhere is without this innovative ladder.

The name Conrad Dietrich Magirus soon gained worldwide renown. The company he founded in 1864 continued to do his reputation justice as a fire-fighting pioneer in the following decades. When the company founder passed on in 1895 at the age of 70, his three sons took the helm at the company and carried on his life-work.

Magirus remains the epitome of innovation, having introduced the elevator patent ladder, the petrol driven fire pump, the first self-propelled electric turntable ladder, the first light pumper with a 1.5 ton chassis, the early predecessors of the tank pumpers, the so-called "water wagons", and the first motorised tank pumper capable of carry large amounts of water and foam compound, a built-in front-end Magirus pump and two quick attack units: The first airport fire-fighting vehicle.







**At home in Germany. On the job around the world.**

A lot has changed since the beginning, and a lot has stayed the same. Today Magirus still embodies the spirit of new ideas, innovative technologies, outstanding quality, perfection in craftsmanship and absolute practical orientation.

Fire brigades and disaster protection teams around the world count on Magirus developments. And they're not disappointed, as is demonstrated by countless international awards and most of all by the large number of fire brigades who tell us about their toughest missions and the outstanding performance of our products.

We employ approximately 1300 people at 4 locations around the world. Our competence centre for fire-fighting vehicles in Chambéry electrifies French customers, in Kainbach Austria we produce vehicles for fire brigades in Austria, South Tyrol and neighbouring Eastern European countries. We produce airport fire-fighting vehicles as well as special vehicles and forest-firefighting vehicles in Brescia, Italy. And the heart of Magirus still beats in Ulm, Germany, in our competence centre for fire-fighting which we call the Excellence Center.

In 2013, Magirus became part of CNH Industrial, a group of companies born from Fiat Industrial and CNH Global. CNH Industrial was created in 2013 from Fiat Industrial and CNH Global. It is among the world's largest companies in the investment goods sector.

Members of the corporate group include renowned manufacturers such as CaseIH, Steyr and New Holland (products for the agriculture and construction industries), Iveco (trucks, special vehicles and buses) and FPT Industrial (engines, transmissions and axles). CNH Industrial is represented in 190 countries with 12 brands, 64 factories, 48 research and development centres, 71,000 employees and a sales network of approximately 10,000 dealers. This lets Magirus rely on a worldwide network of engineers as well as on technologies developed group-wide and lets us leverage special synergies.



**Around the globe Magirus embodies the art of engineering and quality, proven in practice thousands of times.**



# FITTINGS & HOSES









## PRESSURE HOSES

FITTINGS &amp; HOSES

Product	Name	Description	Length (m)	Part no.
	<b>Pressure hose GH Titan FLAME D 25</b>	DIN14811/A3:2018-12, Class 1, 4 yellow identification stripes, hose guard Water loss 2l/min at 100m with 6bar. Max. operating pressure 16bar.  <b>Other coupling-systems on request.</b>	15 20 30	579816539 579816540 579816541
	<b>Pressure hose GH Titan 3F A 110</b>	DIN 14811. Inside-Ø 110mm. Ageing & ozone resistant. Inner core resistant against seawater and many chemicals. Hose-guard collar.  <b>Other coupling-systems on request.</b>	5 15 20	579805269 579804569 579807026
	<b>Pressure hose GH Titan 3F B 75</b>  <b>Pressure hose GH Titan 3F B 75, pawl</b>	DIN 14811. Inside-Ø 75mm. Ageing & ozone resistant. Inner core resistant against seawater and many chemicals. Hose-guard collar.  <b>Other coupling-systems on request.</b>	5 15 20 35	579800093 579804280 579800094 579800099
	<b>Pressure hose GH Titan 3F NEON B 75</b>  <b>Pressure hose GH Titan 3F NEON B 75, pawl</b>	DIN 14811. Inside-Ø 75 mm. Visible in darkness and smoke. Inner core resistant against seawater and many chemicals. Hose-guard collar.  <b>Other coupling-systems on request.</b>	5 15 20 35	579800103 579808189 579800104 579800109
	<b>Pressure hose GH Titan 3F C 42</b>	DIN 14811. Inside-Ø 42mm. Ageing & ozone resistant. Inner core resistant against seawater and many chemicals. Hose-guard collar.  <b>Other coupling-systems on request.</b>	5 15 20 30	579804809 579800095 579800096 579804322
	<b>Pressure hose GH Titan 3F NEON C 42</b>	DIN 14811. Inside-Ø42 mm. Visible in darkness and smoke. Inner core resistant against seawater and many chemicals. Hose-guard collar.  <b>Other coupling-systems on request.</b>	5 15 20 30	579805586 579800105 579800106 579804583
	<b>Pressure hose GH Titan 3F C 52</b>	DIN 14811. Inside-Ø 52mm. Ageing & ozone resistant. Inner core resistant against seawater and many chemicals. Hose-guard collar.  <b>Other coupling-systems on request.</b>	15 20	579800097 579800098

## PRESSURE HOSES

Product	Name	Description	Length (m)	Part no.
	<b>Pressure hose GH Titan 3F NEON C 52</b>	DIN 14811. Inside-Ø 52 mm. Visible in darkness and smoke. Inner core resistant against seawater and many chemicals. Hose-guard collar.  <b>Other coupling-systems on request.</b>	15 20	579800107 579800108
	<b>Pressure hose GH Titan 3F Signal C 52</b>	DIN 14811. Inside-Ø52 mm. Visible in darkness and smoke. Inner core resistant against seawater and many chemicals. Hose-guard collar.  <b>Other coupling-systems on request.</b>	15 20	579807079 579816538
	<b>Pressure hose GH Titan 3F D 25</b>	DIN 14811. Inside-Ø25mm. Ageing & ozone resistant. Inner core resistant against seawater and many chemicals. Hose-guard collar.  <b>Other coupling-systems on request.</b>	5 15 20 30	579800101 579800102 579804281 579804486





**GOLLMER & HUMMEL**  
hoses for heroes





[www.gollmer-hummel.net/en/](http://www.gollmer-hummel.net/en/)

**We are  
IN LOVE WITH HOSES  
since 1872**

## PRESSURE HOSES

FITTINGS &amp; HOSES

Product	Name	Description	Length (m)	Part no.
	<b>Pressure hose GH Titan 3F NEON D 25</b>	DIN 14811. Inside-Ø25 mm. Visible in darkness and smoke. Inner core resistant against seawater and many chemicals. Hose-guard collar.  <b>Other coupling-systems on request.</b>	5	579800110
			15	579800111
			20	579804374
			30	579815941

### PRESSURE HOSE GOLLMER & HUMMEL GH TITAN COMBAT











Due to its flexibility, the GH Titan Combat is an excellent rapid deployment hose. It is approved according to DIN performance level 2 and reaches DIN performance level 3 during practical application. The hose is wrapped in stainless steel wire and a hose guard collar included as standard.



**Other coupling-systems on request.**

    	<b>Pressure hose GH Titan Combat B 75</b>	DIN 14811. Inside-Ø 75 mm. Triple twined chain. Inner core resistant against seawater, chemicals, UV radiation and ozone. Hose-guard collar, DIN performance level 3	5 20	579805233 579805234	
	<b>Pressure hose GH Titan Combat B 75, pawl</b>		35	579806528	
	<b>Pressure hose GH Titan Combat NEON B 75</b>	DIN 14811. Inside-Ø 75 mm. Triple twined chain. Visible in darkness and smoke. Inner core resistant against seawater, chemicals, UV radiation and ozone. Hose-guard collar, DIN performance level 3	5 20	579805696 579805697	
	<b>Pressure hose GH Titan Combat NEON B 75, pawl</b>		35	579805495	
	<b>Pressure hose GH Titan Combat NEON B 75</b>	DIN 14811. Inside-Ø 75 mm. Triple twined chain. Visible in darkness and smoke. Inner core resistant against seawater, chemicals, UV radiation and ozone. Hose-guard collar, DIN performance level 3	5 20 35	579805801 579805802 579808148	
	<b>Pressure hose GH Titan Combat C 52</b>	DIN 14811. Inside-Ø 52 mm. Triple twined chain. Visible in darkness and smoke. Inner core resistant against seawater, chemicals, UV radiation and ozone. Hose-guard collar, DIN performance level 2	15 20 30	579805541 579806715 579805570	
	<b>Pressure hose GH Titan Combat C 42</b>	DIN 14811. Inside-Ø42 mm. Triple twined chain. Inner core resistant against seawater, chemicals, UV radiation and ozone. Hose-guard collar, DIN performance level 2	15 20 30	579804580 579806106 579805525	
	<b>Pressure hose GH Titan Combat NEON C 42</b>	DIN 14811. Inside-Ø42 mm. Triple twined chain. Visible in darkness and smoke. Inner core resistant against seawater, chemicals, UV radiation and ozone. Hose-guard collar, DIN performance level 2	15 20 30	579805209 579805698 579806387	
	without image	<b>Label Pressure hose</b>	Only with new orders. Both ends of hose, depending customer specifications.		579804921
		<b>Label Pressure hose</b>	Only with new orders. Both ends of hose and middle, depending customer specifications.		579807303

## PRESSURE HOSES

Product	Name	Description	Length (m)	Part no.
	<b>Pressure hose GH Titan X-Treme B 75</b>	DIN 14811. Inside-Ø75 mm. High visibility when battling interior fires, low friction loss, hose-guard collar, DIN performance level 3	5 20	579800122 579800123
	<b>Pressure hose GH Titan X-Treme NEON B 75, pawl</b>		35	579800128
	<b>Pressure hose GH Titan X-Treme NEON C 42</b>	DIN 14811. Inside-Ø42 mm. High visibility when battling interior fires, low friction loss, hose-guard collar, DIN performance level 3  <b>Other coupling-systems on request.</b>	15 20	579800124 579800125
	<b>Pressure hose GH Titan X-Treme NEON C 42</b>	DIN 14811. Inside-Ø42 mm. High visibility when battling interior fires, low friction loss, hose-guard collar, DIN performance level 3  <b>Other coupling-systems on request.</b>	30	579804640
	<b>Pressure hose GH Titan X-Treme NEON C 52</b>	DIN 14811. Inside-Ø52 mm. High visibility when battling interior fires, low friction loss, hose-guard collar, DIN performance level 3  <b>Other coupling-systems on request.</b>	15 20 35	579800126 579800127 579806529
	<b>Pressure hose GH Titan X-Treme NEON D 25</b>	DIN 14811. Inside-Ø25 mm. High visibility when battling interior fires, low friction loss, hose-guard collar  <b>Other coupling-systems on request.</b>	15 20 30	579805932 579806556 579815423
	<b>Pressure hose GH Titan Attack NEON C 42</b>	DIN 14811/A2:2014-08, Class 1, Performance Level 3, hose-guard, fourfold twined chain, burst pressure over 85bar  <b>Other coupling-systems on request.</b>	15 20 30	579808352 579808353 579808354
	<b>Pressure hose GH Titan Attack NEON C 42</b>	DIN 14811/A2:2014-08, Class 1, Performance Level 3, hose-guard, fourfold twined chain, burst pressure over 85bar  <b>Other coupling-systems on request.</b>	15 20 30	579808358 579808357 579808355

Other lengths on request.

## HOSES

Product	Name	Description	Length (m)	Part no.
	<b>Rapid deployment hose TEXFLEX X-TREME Storz C</b>	<p><b>Benefits</b></p> <ul style="list-style-type: none"> <li>• Exceptionally light, resistant to bending and flexible (even at very cold temperatures)</li> <li>• Extremely small bend radius and high abrasion resistance due to 4Z weave</li> <li>• Reelable</li> <li>• Reduced tendency to twist and expand</li> <li>• Very good adhesion values between rubber and fabric</li> <li>• Distinctive design with contrasting weave for high visibility</li> </ul> <p><b>Material composition fabric:</b></p> <ul style="list-style-type: none"> <li>• High-strength polyester yarn, spun dyed, endless woven</li> <li>• Monofilaments used for inlays to guarantee shape retention</li> <li>• Special construction for high pressure and very tight bend radii</li> </ul> <p><b>Inner core:</b></p> <ul style="list-style-type: none"> <li>• Made from high quality EPDM rubber, flexible at low temperatures, suitable for hot water</li> </ul> <p> <b>Other coupling-systems on request.</b></p>	50	579815571
	<b>Rapid deployment hose MONOFLEX blue</b>	Shape-retaining DIN-rapid deployment hose, integrated with C-Storz. Effective burst pressure at 160 bar. DIN EN 1947-II-B-5, Storz C, flame-retardant, weather-proof, bend protection on both ends, operating pressure max. 40 bar, length 50 m.	50	579800090
	<b>Rapid deployment hose MONOFLEX orange</b>			579804462
	<b>Suction hose KW Storz A 1,6m</b>	DIN EN ISO 14557. Inside-Ø110 mm, Connector nominal size Storz 2 x A	1,6	579800657
	<b>Suction hose KW, Storz A 1,6 m incl. Coupling handles</b>	DIN EN ISO 14558. Inside-Ø110 mm, Connector nominal size Storz 2 x A	1,6	579800658
	<b>Suction hose KW Storz A</b>	DIN EN ISO 14557, Inside-Ø110 mm, Connector 2x Storz A	2,0	579804004
	<b>Suction hose Storz A 2,5m</b>	DIN EN ISO 14557, Inside-Ø110 mm Connector nominal size Storz 2 x A	2,5	579800656
	<b>Coupling handle</b>	For size Storz A 110 incl. mounting material	16	579800706
	<b>Lever hose bandage PERFECT 38</b>	Hose inside-Ø38mm, lever fastener.		579800712
	<b>PERFEKT 42</b>	Hose inside-Ø42 mm, lever fastener.		579800713
	<b>PERFEKT 52</b>	Hose inside-Ø52 mm, lever fastener.		579800710
	<b>PERFEKT 75</b>	Hose inside-Ø75 mm, lever fastener.		579800709
	<b>PERFEKT 110</b>	Hose inside-Ø110mm, lever fastener.		579800711



## HOSE ACCESSORIES

Product	Name	Description	Material	Part no.
	<b>Hose protection ramp 2B/2C</b>	DIN 14820, for two B or C pressure hoses.	Wood	579802912
	<b>Hose protection ramp 2B/2C</b>	For two B or C pressure hoses. Freely expendable in width Lateral reflective stripes.	Rubber	579802913
	<b>Hose protection ramp Crocodile, Type B</b>	For two B or C pressure hoses, foldable, high slip resistance due to floor ribs, knobs to connect several hose protection ramps.	Rubber	579802914
	<b>Hose protection ramp Crocodile, Type B</b>	For two B or C pressure hoses, incl. drive-over protection, foldable, high slip resistance due to floor ribs, knobs to connect several hose protection ramps.	Rubber	579802915
	<b>Hose protection ramp</b>	For two B or C pressure hoses. Incl. ramp parts and profiled slip rubber.	Aluminium	579802916

# THE NEW BINDING SYSTEM, DESIGNED AND DEVELOPED BY GOLLMER & HUMMEL



## BENEFITS

- The GH EASY-FIX System has been on the market for an extended period and is deployed by many fire departments
- Based on extensive user feedback, a new, modified version of the assembly device was developed: the GH EASY-FIX evo2
- The system supports continued use of conventional DIN-pressure couplings (2008 and later) in sizes C/42, C/52, B/75. GH EASY-FIX makes assembly and disassembly a breeze, even for the technically inexperienced. Additionally, you save a tremendous amount of time and expenses compared to conventional wire binding.
- Significantly lighter
- Handy and space-saving
- Horizontal and vertical assembly possible

## HIGHLIGHTS

- All GH EASY-FIX components are reusable
- Already existing DIN-pressure couplings can still be used, thanks to a special retrofit kit (consisting of inner and outer ring)
- No skidding with a positive locked hose
- The cone-shaped outer ring serves as edge protector and prevents getting caught in edges, corners, and steps
- Time & Cost saving
- Easy to handle
- Safe assembly

## HOSE ACCESSORIES

Product	Name	Description	Size	Part no.
	<b>Binding system Easy-Fix</b>	Only if ordered with new hose incl. Pressure couplings. Produced by Gollmer & Hummel	B75 C52 C42	579808343 579808342 579808340
	<b>Retro-fit kit Coupling Easy-Fix</b>	To connect existing hoses without couplings. Kit contains connecting nozzles, cleat fittings, inner and outer sleeve	B75 C52 C42	579808344 579808345 579808346
without image	<b>Retro-fit kit Easy-Fix</b>	To connect existing hoses. Kit contains inner and outer sleeve	B75 C52 C42	579808349 579808348 579808347
	<b>Velcro strap</b>	For hose package, red. For hose package, yellow.	70	579805844 579807602
	<b>Hose carrying strap</b>		1000	579807289

# HOSE CARRYING BASKET FLEXATTACK® „WALDBRAND“





## BENEFITS

- The flexattack® forest fire basket keeps your fastest and most required tools organized on the way to the deployment site. Inlets at the fitting section allow for quick and easy extraction of steel pipe and distributor without opening the entire basket. The hose carrying basket comes with the same useful features as the entire flexattack® portfolio (extraction of hoses, easy equipping). Fits vehicle mounts for hose carrying baskets C
- The forest fire basket provides space for 3 D-hoses at 20m, 3 steel pipes Storz D without handle and 1 distributor C-DDD. Extraction without opening the basket is possible.
- Delivery without content!

## FEATURES

- Plastic with high temperature and chemical resistance
- Modular design to swap out individual parts if required
- Produced exclusively in Germany (District of Neu-Ulm)





## HOSE CARRYING BASKETS FOREST FIRES

Product	Name	Description	Length (mm)	Part no.
	<b>Hose carrying basket C for „Waldbrand“ Flexattack</b>	Holds 3 D-hoses at 20m, 3 steel pipes Storz D without handle and 1 distributor C-DDD. Extraction without opening the basket is possible.	870	579807667
	<b>Dönges Forest fire basket Wakob</b>	Measurements identical to hose carrying basket C according DIN 14827, practical transport of equipment, without content	870	579815419
	<b>Dönges Forest fire basket Wakob, incl. fittings</b>	Measurements identical to hose carrying basket C according DIN 14827, practical transport of equipment, incl. 3 steel pipes AWG HS7, 1 distributor C-DDD, 1 transition piece C-D (without hoses)	870	579815418



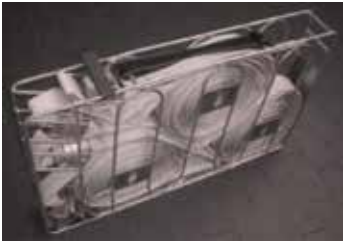





## HOSE CARRYING BASKETS/BAGS

Product	Name	Description	Length (mm)	Part no.
	<b>Rapid deployment bag „de Vries“, rescue-tec</b>	For D-hose, 30m, bag delivered without content.	510	579805077
	<b>Hose carrying basket B, foldable</b>	DIN 14827. Holds space for 2 x 20 m B-hoses.	870	579802918
	<b>Hose carrying basket C, foldable</b>	DIN 14827. Holds space for 3 x 15 m C-hoses.		579802917
	<b>Hose package basket B Profi ultra</b>	Hose package basket B Profi ultra with centred panel to house several B-hoses	870	579801740
	<b>Hose package basket C Profi ultra</b>	Hose package basket C Profi ultra with centred panel to house several C-hoses		579801739
	<b>Hose carrying basket B, foldable, Flexattack</b>	For 3 B-hoses á 20m.	870	579807666
	<b>Hose carrying basket C, foldable, Flexattack</b>	For 3 C-hoses á 15m.		579805699
	<b>Hose carrying basket flexattack® D</b>	Without separator plate, to house 3 x 15m D-pressure hose, lengthwise handle, 2 STK-D fit in one STK-C storage due to shorter length	435	579816543
	<b>Hose carrying basket flexattack® D</b>	Incl. separator plate	435	579816542
	<b>Hose carrying basket flexattack® C-D 90</b>	Incl. Separator plate, to house 6 x D-hoses, 15m & 1 D-steel pipe	870	579809911

## HOSE CARRYING BASKETS/BAGS







Product	Name	Description	Length (mm)	Part no.
	<b>Hose wrapping basket B</b>	for 2 B-hoses with valve & 2 impellers	870	579805565
	<b>Hose wrapping basket C</b>	For 3 C-hoses with valve	870	579804317
	<b>Retaining plate for hose wrapping basket B</b>	Allows to hang hose wrapping basket B in access ladder		579806550
	<b>Retaining plate for hose wrapping basket C</b>	Allows to hang hose wrapping basket C in access ladder		579804318
	<b>Crank for hose wrapping basket</b>	Robust and high-quality crank, fits all hose wrapping baskets, used to reel in hoses.		579804319
	<b>Hose package bag RAP-EX</b>	Suitable for 30m C-42 pressure hose, capacity: 31 litres	870	579807344

## WATER-CONDUCTING FITTINGS









Product	Name	Description	Part no.
	<b>Transition piece KW Storz 125-A110</b>	Nominal size A-125-A-110	579804568
	<b>Transition piece KW Storz A-B</b>	DIN 14343. Nominal size A-110-DS - B-75. Lug space 113/89 mm.	579800671
	<b>Transition piece KW Storz B-C</b>	DIN 14342. Nominal size B-75 - C-52. Lug space 89/66 mm.	579800672
	<b>Transition piece KW Storz C-D</b>	DIN 14341. Nominal size C-52 - D-25-DS. Lug space 66/31 mm.	579800673
ohne Abbildung	<b>Blind coupling B with drain valve</b>	Lug space 66 mm, with chain	579804579
	<b>Fixed coupling C - G 1</b>	Nominal size Storz C. Inlet G 1". Suitable for size M 0,4.	579805512
	<b>Hydrant wrench A, AWG</b>	DIN 3223:2012-11, for aboveground hydrants	579800951
	<b>Hydrant wrench B, AWG</b>	DIN 3223:2012-11, for aboveground hydrants	579800952
	<b>Hydrant wrench B with ratchet</b>	DIN 3223:2012-11, for aboveground hydrants	579804316
	<b>Hydrant wrench C, AWG</b>	DIN 3223:2012-11, for underground hydrants	579800953













## WATER-CONDUCTING FITTINGS

Product	Name	Description	Part no.
	<b>Hydrant wrench C (underground hydrant) with weld-on hook</b>	The weld-on hook enables easy lifting of stuck street caps and manhole covers	579806616
	<b>Hydrant wrench C (Underground hydrant) Flexattack</b>	DIN 3223:2012-11, the lockable lifting clamp enables lifting of stuck hydrant covers	579808445
	<b>Hydrant wrench C Württemberg, AWG</b>	for underground hydrants	579800954
	<b>Hydrant bar iconos</b>	To lift all types of channel covers, hydrant covers and supply lines	579807410
	<b>Manhole cover lifter with handle</b>	For heavy manhole covers. Made of steel, coated in black	579802919
	<b>Hydrant bar with chain, AWG</b>	Pair	579800955
	<b>Cover lifter Kaplift</b>	Using the new KAPLIFT, all corroded, jammed or iced over street hydrant covers can be opened effortless and quick.	579805688













## WATER-CONDUCTING FITTINGS

Product	Name	Description	Part no.
	<b>Manhole cover hammer 320 mm</b>	Non-slip rubber handle, steel pipe shaft, specially forged tip, fits with all channel- and manhole covers	579805645
	<b>Coupling spanner Storz ABC, AWG</b>	DIN 14822. Nominal size 110-75-52 = ABC. Galvanised steel Incl. thermal hand guard.	579800949
	<b>Coupling spanner Magi- rus ABC made of plastic</b>	Tensile strength up to 200 N/mm <sup>2</sup> , temperature range of -40 °C to +100 °C, not sparking & electrically conductive	579808984
	<b>Coupling spanner BC</b>	DIN 14822. Nominal size 75-52 = BC. Thermal guard. Steel	579800688
	<b>Mini coupling spanner UNISEK</b>	Fits all coupling sizes, small and compact	579805825
	<b>Hydrant standpipe AWG DN 80 2B</b>	DIN 14375, Inlet DN 80, Outlet 2 x B Shut-off valve bonnet 2 x 2½"  <b>Other coupling-systems on request.</b>	579800920
	<b>Hydrant standpipe AWG DN 80 2B</b>	DIN 14375, Shut-off valve bonnet 2 x 2½", hydrant standpipe from the drinking water and pipe protection series, incl. non-return & ventilation valves  <b>Other coupling-systems on request.</b>	579804485

## WATER-CONDUCTING FITTINGS

Product	Name	Description	Part no.
	<b>Hydrant standpipe AWG DN 80 2C</b>	Shut-off, valve bonnets: 2 x 2". Rotatable.  <b>Other coupling-systems on request.</b>	579800922
	<b>Hydrant standpipe AWG DN 50 2B, Württemberg</b>	Inlet DN 50, outlet 2 x B, shut-off, valve bonnets 2 x 2½", Württemberg  <b>Other coupling-systems on request.</b>	579800921
	<b>Hydrant standpipe AWG DN50 2B, Württemberg</b>	Shut-off valve bonnets 2 x 2½", Hydrant standpipe from the drinking water and pipe protection series, incl. non-return & ventilation valves  <b>Other coupling-systems on request.</b>	579805211
	<b>Hydrant standpipe AWG DN 50 2C, Württemberg</b>	Shut-off, valve bonnets: 2 x 2" Württemberg  <b>Other coupling-systems on request.</b>	579800923
	<b>Hydrant standpipe extension</b>	Allows use of standpipe DN 80 with Württemberger underground hydrants  <b>Other coupling-systems on request.</b>	579806814













## WATER-CONDUCTING FITTINGS

Product	Name	Description	Part no.
	<b>System separator AWG B-FW</b>	DIN 14346, 2 x Storz 75 (B), flow of min. 1.600 l/min at max. 1 bar pressure loss for annual check of system separators B-FW	579808027
	<b>Test set System separator AWG B-FW</b>	for annual check of system separators B-FW	579808121
	<b>System separator B-FW</b>	DIN 14346, flow rate of 1700 l/min at max. pressure loss of 1 bar. Handle with counter lever for tool-free mounting at hydrant	579809226
	<b>Suction strainer A AWG</b>	DIN 14362. Nominal size 100. Outlet Storz/A, incl. non-return valve and drain arrangement.  <b>Other coupling-systems on request.</b>	579800916
	<b>Suction strainer A with coupling handles AWG</b>	Nominal size 100. Outlet Storz/A, incl. non-return valve and drain arrangement.  <b>Other coupling-systems on request.</b>	579805066
	<b>Suction strainer B, AWG</b>	DIN 14362. Nominal size 65. Outlet Storz/B, incl. non-return valve and drain arrangement.  <b>Other coupling-systems on request.</b>	579804284
	<b>Suction strainer C AWG</b>	DIN 14362, Nominal size 45, Outlet Storz C, incl. non-return valve and drain arrangement.  <b>Other coupling-systems on request.</b>	579816544
	<b>Suction strainer DN125, AWG</b>	Nominal size 125. Outlet Storz/125, incl. non-return valve and drain arrangement.  <b>Other coupling-systems on request.</b>	579804490

















## WATER-CONDUCTING FITTINGS

Product	Name	Description	Part no.
	<b>Suction strainer basket size A, AWG</b>	Nominal size DN 100 /Storz A, foldable, with elastic band	579800919
	<b>Suction strainer basket size A, AWG</b>	Nominal size DN 100 /Storz A, foldable, with tightening ring	579805018
	<b>Suction strainer basket size DN 125</b>	Nominal size DN 125, foldable, with elastic band	579804594
	<b>Suction strainer Amphibio buoyant</b>	Flow of up to 2700 l/min. Connection fixed coupling A-DS=110 mm, suitable for water extraction from all open waters with min. water depth of 20mm, robust casing with two handles.  <b>Other coupling-systems on request.</b>	579810029
	<b>Suction strainer Amphibio Mini buoyant</b>	Flow of up to 1800 l/min.  <b>Other coupling-systems on request.</b>	579815773
without image	<b>Buoy</b>	PVC-coated, inflatable buoy, 50 x 50 cm	579802635
	<b>Buoy</b>	With Schrader valve and air pump	579805857
	<b>Siamese AWG A-2B</b>	DIN 14355, outlet rotatable, Inlet Storz/2 x B, Outlet Storz/A, with pendulum flap.  <b>Other coupling-systems on request.</b>	579800924
	<b>Siamese AWG A-2B</b>	DIN 14355. Inlet Storz 2x75 B, Outlet Storz A rotatable, Drinking water & pipe protection series  <b>Other coupling-systems on request.</b>	579804378









## WATER-CONDUCTING FITTINGS

Product	Name	Description	Part no.
	<b>Siamese AWG A-3B</b>	DIN 14355, Inlet Storz/, 3 x B Outlet Storz/A, with single flaps  <b>Other coupling-systems on request.</b>	579800925
	<b>Siamese AWG A-3B</b>	DIN 14355. Inlet Storz 3x75 B, Outlet Storz A rotatable, drinking water & pipe protection series  <b>Other coupling-systems on request.</b>	579804893
	<b>Siamese AWG Storz 125-2B</b>	Inlet 2x 75-B, Outlet 125  <b>Other coupling-systems on request.</b>	579804595
without image	<b>Siamese 125 - 3B, AWG</b>	Outlet rotatable, Outlets Storz 3 x B, Outlet Storz 125.  <b>Other coupling-systems on request.</b>	579804455
	<b>Siamese 125-3B, AWG</b>	Outlet rotatable, Outlets Storz 3 x B, Outlet Storz 125, drinking water & pipe protection series, Colour: red.  <b>Other coupling-systems on request.</b>	579808659
without image	<b>Distributor A-BB AWG, with crew down valve</b>	Inlet Storz A 110, Outlet 2x Storz B  <b>Other coupling-systems on request.</b>	579809479
	<b>Distributor A-BB AWG, with ball valve shut-off</b>	Inlet Storz A 110, Outlet 2x Storz B  <b>Other coupling-systems on request.</b>	579807529
	<b>Distributor B-CC AWG, with screw down valve</b>	Inlet Storz B, Outlet 2x Storz C  <b>Other coupling-systems on request.</b>	579816547
	<b>Distributor B-CC AWG, with ball valve shut-off</b>	Inlet Storz B, Outlet 2x Storz C  <b>Other coupling-systems on request.</b>	579807967

## WATER-CONDUCTING FITTINGS











Product	Name	Description	Part no.
	<b>Distributor AWG B-CBC, with screw down valve</b>	DIN 14345. Incl. Transition piece B-C and chain, Inlet Storz B, Outlet Storz 2x C+B, Valve bonnet 2x 2" + 2½"  <b>Other coupling-systems on request.</b>	579800926
	<b>Distributor AWG B-CBC, with ball valve shut-off</b>	DIN 14345. Incl. Transition piece B-C and Chain, Inlet Storz B, Outlet Storz 2x C+B, Valve bonnet 2x 2" + 2½"  <b>Other coupling-systems on request.</b>	579800927
	<b>Distributor AWG BB-CBC, with screw down valve</b>	DIN 14345. Incl. Transition piece B-C and Chain, Inlet 2x Storz B, Outlet Storz 2x C+B, Valve bonnet 2x 2" + 2½"  <b>Other coupling-systems on request.</b>	579800928
	<b>Distributor AWG BB-CBC, with ball valve shut-off</b>	DIN 14345. Incl. Transition piece B-C and Chain, Inlet 2x Storz B, Outlet Storz 2x C+B, Valve bonnet 2x 2" + 2½"  <b>Other coupling-systems on request.</b>	579800929
	<b>Distributor AWG C-DCD, with screw down valve</b>	DIN 14345. Incl. Transition piece C-D and Chain, Inlet Storz C, Outlet Storz 2x D+C, Valve bonnet 2x 1" + 2"  <b>Other coupling-systems on request.</b>	579800930
	<b>Distributor C-DDD FI-exattack, with ball valve shut-off</b>	for Hose carrying basket flexattack® WALDBRAND  <b>Other coupling-systems on request.</b>	579809096
	<b>Distributor C-DDD AWG, with ball valve shut-off</b>	Specifically designed to fight wildfires. Storage in STK-C possible, according to DIN.  <b>Other coupling-systems on request.</b>	579816545
	<b>Pressure relief valve B AWG</b>	DIN 14380. In- and Outlet Storz rotatable 2 x B. Overflow Storz B.  <b>Other coupling-systems on request.</b>	579800956

## WATER-CONDUCTING FITTINGS

Product	Name	Description	Part no.
	<b>Hose shut-off B with Ball valve AWG</b>	Connection system Storz. Nominal size DN 40, Outlet/Inlet Storz B.  <b>Other coupling-systems on request.</b>	579800961
	<b>Hose shut-off C with Ball valve AWG</b>	Connection system Storz, Nominal size DN 32, Outlet/Inlet Storz C.  <b>Other coupling-systems on request.</b>	579800960
	<b>Pipe elbow 90° A, AWG</b>	Inlet Storz A rotatable, Outlet Storz A.	579805384
	<b>Pipe elbow 90° B, AWG</b>	Inlet Storz B rotatable, Outlet Storz B.	579800965
	<b>Pipe elbow 90° C, AWG</b>	Inlet Storz C rotatable, Outlet Storz C.  <b>Other coupling-systems on request.</b>	579800964
	<b>Branch pipe holder Storz B, AWG</b>	DIN 14368. Inlet Storz B. Outlet Storz B. Rotatable.	579800934
	<b>Branch pipe holder Storz C, AWG</b>	Inlet Storz C52, Outlet Storz C52, rotatable.  <b>Other coupling-systems on request.</b>	579804283



## WATER-CONDUCTING FITTINGS MAGIRUS

Product	Name	Description	Part no.
	<b>Foam inductor Magirus Z2, Storz C</b>	DIN 14384, in- & outlet Storz C, foam proportioning rate 0,5 - 6 %, flow rate 200 l/min, carrying handle.  <b>Other coupling-systems on request.</b>	579807540
	<b>Pressure relief valve Magirus, Storz B</b>	DIN 14380, in- & outlet Storz B  <b>Other coupling-systems on request.</b>	579807665
	<b>Distributor Magirus B-CBC with screw down valve shut-off</b>	DIN 14345, Inlet Storz B, Outlet Storz 2x C+ 1x B  <b>Other coupling-systems on request.</b>	579807652
	<b>Distributor Magirus B-CBC with ball valve shut-off</b>	DIN 14345, Inlet Storz B, Outlet Storz 2x C+ 1x B  <b>Other coupling-systems on request.</b>	579807653
	<b>Branch pipe holder Magirus Storz B</b>	DIN 14368  <b>Other coupling-systems on request.</b>	579815587

# MAGIRUS QC (QUICK CONNECT)



Magirus QC (Quick Connect) enables fast deployment of different add-ons such as a slow expansion foam, piercing applicators etc. without removing the nozzle. It increases safety during indoor firefighting, as water can be pumped consistently through the nozzle. Therefore, loss during low visibility is eliminated.

Adjustable type of stream, ranging from hard jet, to spray jet and spray jet with firefighter protection effect. All types of stream securely fixed through snap-in point. Flow rate from 80 to 235l/min managed via four snap-in points of rotating bezel. Pointer at 130l/min setting improved and even better to feel, which further improves orientation at low visibility. Flush position to flush out dirt particles available during deployment. Ergonomic, removable plastic pistol grip and smooth-running

aluminium gear lever. Robust make with high-quality materials. Chromium-plated messing ball in switchgear. Inlet rotatable under pressure.

## FEATURES





- EN 15182-2
- Flow pattern settings at 6 bar 80-130-180-235 l/min.
- Inlet Storz C rotatable

Part no. 579815874

## NOZZLES MAGIRUS

Product	Name	Description	Length (mm)	Part no.
	<b>Nozzle Magirus QC-500 B</b>	The QC series is the ideal nozzle for different add-ons and indoor firefighting. EN 15182-2. Inlet Storz B rotatable. Flow pattern settings at 6 bar 100-250-350-500 l/min.  <b>Other coupling-systems on request.</b>	303	579815876
	<b>Nozzle Magirus QC-400 C</b>	EN 15182-2. Inlet Storz C rotatable. Flow pattern settings at 6 bar 100-200-300-400 l/min.  <b>Other coupling-systems on request.</b>	303	579815875
	<b>Nozzle Magirus QC-235 C</b>	EN 15182-2. Inlet Storz C rotatable. Flow pattern settings at 6 bar 80-130-180-235 l/min.  <b>Other coupling-systems on request.</b>	303	579815874
	<b>Nozzle Magirus WF-180 D</b>	Compact construction and maximum flow volume makes the WF series ideal for forest fire fighting. EN 15182-2. Inlet Storz D. Flow pattern settings at 6 bar 40-80-130-180 l/min.  <b>Other coupling-systems on request.</b>	230	579815873
	<b>Nozzle Magirus WP-1000 B</b>	The WP series is the ideal nozzle to fight large fires. Its hollow stream effect allows generation of low expansion foam without foam nozzles. EN 15182-2. Inlet Storz B rotatable. Flow pattern settings at 6 bar 400-600-800-1.000 l/min.  <b>Other coupling-systems on request.</b>	303	579815879
	<b>Nozzle Magirus WP-750 B</b>	EN 15182-2. Inlet Storz B rotatable. Flow pattern settings at 6 bar 360-475-550-750 l/min.n.in.  <b>Other coupling-systems on request.</b>	303	579815878
	<b>Low expansion foam add-on for all Magirus QC nozzles</b>	Suitable for all ND & HD hollow foam nozzles	389	579815880

## NOZZLES MAGIRUS







Product	Name	Description	Length (mm)	Part no.
	<b>Piercing applicator for all Magirus QC nozzles</b>	Suitable for all ND & HD hollow foam nozzles		579815881
	<b>High pressure nozzle Magirus 180 D</b>	EN 15182-2. Inlet Storz D rotatable. Flow pattern settings at 6 bar 50-100-150-180 l/min.	303	579807944
	<b>Combination foam branch pipe Magirus K2, Storz C</b>	DIN 14366. Switchable. Ball valve shut-off and C fixed coupling. Mixture flow 200 l/min. at 5 bar.  <b>Other coupling-systems on request.</b>	610	579807542

## NOZZLES

Product	Name	Description	Length (mm)	Part no.
	<b>Multi-purpose nozzle BM, DIN, AWG</b>	Nominal size BM. Inlet Storz B. Ø Nozzle x Ø Mouth- piece 22 x 16.  <b>Other coupling-systems on request.</b>	500	579800939
	<b>Multi-purpose nozzle BM VSP, DIN, AWG</b>	Hard jet locking mechanism. Connection system Storz. Inlet Storz B. Ø Nozzle x Ø Mouthpiece 22x16.  <b>Other coupling-systems on request.</b>	500	579800940
	<b>Multi-purpose nozzle BMM VSP, AWG</b>	DIN EN 15182-3:2010-04, with hard jet locking mechanism and additional water curtain, Nominal size BMM, Inlet Storz B  <b>Other coupling-systems on request.</b>	450	579807583
	<b>Multi-purpose nozzle CM, AWG</b>	DIN EN 15182-3:2010-04, with Nominal size CM, Inlet Storz  <b>Other coupling-systems on request.</b>	450	579800942
	<b>Multi-purpose nozzle CM VSP, AWG</b>	DIN EN 15182-3:2010-04, with hard jet locking mechanism, Nominal size CM, Inlet Storz C  <b>Other coupling-systems on request.</b>	450	579800943
	<b>Multi-purpose nozzle CMM VSP, AWG</b>	DIN EN 15182-3:2010-04, with Hard jet locking mechanism and additional water curtain, Nominal size CMM, Inlet Storz C  <b>Other coupling-systems on request.</b>	450	579807582
	<b>Multi-purpose nozzle DM, AWG</b>	DIN EN 15182-3. Nozzle Ø 6 mm, mouthpiece Ø 4 mm, Inlet: 25-D  <b>Other coupling-systems on request.</b>	300	579800946
	<b>Water shield B AWG</b>	Inlet Storz B, 1400 l/min	240	579801001
	<b>Water shield C AWG</b>	Inlet Storz C, 800 l/min.  <b>Other coupling-systems on request.</b>		579801000
	<b>Nozzle AWG Turbo-Nozzle 2950 B, with handle</b>	DIN 14367. Inlet B. Flow pattern settings 550-750-950 l/min.  <b>Other coupling-systems on request.</b>	380	579800938

## NOZZLES

FITTINGS &amp; HOSES

Product	Name	Description	Length (mm)	Part no.
	<b>Turbo-Nozzle tip AWG Turbo-Nozzle 2750 B, with handle</b>	DIN EN 15182. Storz B. Flow pattern settings 360-550-750 l/min.	380	579800937
	<b>Nozzle AWG Turbo-Nozzle 2400 Storz B, with handle</b>	DIN 14367. Flow pattern settings 130-235-400 l/min.	320	579800936
	<b>Nozzle AWG Turbo-Nozzle 2400 Storz C, with handle</b>	DIN 14367. Flow pattern settings 130-235-400 l/min.  <b>Other coupling-systems on request.</b>	290	579800945
	<b>Nozzle AWG Turbo-Nozzle 2235 Storz C, with handle</b>	DIN EN 15182. Flow pattern settings 60-130-235 l/min.  <b>Other coupling-systems on request.</b>	290	579800944
	<b>Nozzle AWG Turbo-Nozzle 2235 C, without handle</b>	DIN EN 15182-2:2010-04 Type 3, Flow pattern settings 60-130-235 l/min, without handle.  <b>Other coupling-systems on request.</b>	290	579805014
	<b>Nozzle AWG Turbo-Nozzle 2130 Storz C, with handle</b>	DIN 14367. Flow pattern settings 40-80-130 l/min.	265	579800948
	<b>Nozzle AWG Turbo-Nozzle 2130 Storz D, with handle</b>	DIN EN 15182. Flow pattern settings 40-80-130 l/min.	265	579800947
	<b>Nozzle AWG Turbo-Nozzle 2090 Storz D, with handle</b>	EN 15182, Flow of 30-60-90 l/min at 6 bar, max. working pressure 16 bar, designed for wildfires and forest firefighting  <b>Other coupling-systems on request.</b>	253	579809228
	<b>Nozzle AWG HS7, Inlet Storz 25-D</b>	Flow of 80 l/min. at 6 bar, Throw distance Hard jet/ Spray jet: 26/8m, Storz D  <b>Other coupling-systems on request.</b>	262	579805079

## NOZZLES

Product	Name	Description	Length (mm)	Part no.
	<b>Turbo-Nozzle tip AWG HS7, Inlet Storz 25-D with handle</b>	Flow of 80 l/min. at 6 bar, Throw distance Hard jet/ Spray jet: 26/8m, Storz D	262	579807624
<b>FOAM ATTACHMENT FOR NOZZLES AWG</b>				
	<b>for Turbo-Nozzle 2130</b>	For Turbo-Nozzle 2130 with screws.	225	579800970
	<b>for Turbo-Nozzle 2235 + 2400</b>	DIN 14367. Suitable for all common polyvalent and film-forming foams.	285	579800971
	<b>for Turbo-Nozzle 2750 + 2950</b>	DIN 14367. Suitable for all common polyvalent and film-forming foams.	370	579800972
	<b>Shut-off unit Turbo Twist TT B-75, AWG</b>	Nozzle with self-locking bayonet.	230	579800974
	<b>Shut-off unit AWG Turbo Twist TT C-52</b>	Nozzle with self-locking bayonet.	200	579800973
	<b>Nozzle AWG Turbo Twist T 2130 TT</b>	DIN 14367. Select flow volume at 6 bar: 40/80/130 l/min.  <b>Other coupling-systems on request.</b>	167	579800975
	<b>Nozzle AWG Turbo Twist T 2235 TT</b>	DIN 14367. Select flow volume at 6 bar: 60/130/235 l/min.  <b>Other coupling-systems on request.</b>	180	579800976

## NOZZLES

FITTINGS &amp; HOSES





Product	Name	Description	Length (mm)	Part no.
	<b>Nozzle AWG Turbo Twist T 2400 TT</b>	DIN 14367. Select flow volume at 6 bar 130/235/400 l/min.  <b>Other coupling-systems on request.</b>	187	579800977
	<b>Nozzle AWG Turbo Twist T 2750 TT</b>	DIN 14367. Select flow volume at 6 bar: 360/550/750 l/min. Measurements Ø113 mm  <b>Other coupling-systems on request.</b>	235	579800978
	<b>CAFS tip AWG Turbo-Twist</b>	Inlet: TT, Nominal size: D 25	134	579807253
	<b>CAFS tip AWG Turbo-Twist</b>	Inlet: TT, Nominal size: D 32	134	579806260
	<b>Piercing nozzle TT, Set</b>	Consisting of: Tip and Piercing nozzle, Turbo-Twist		579800980
	<b>Flat jet nozzle AWG TT horizontally, Turbo Twist</b>	Throw distance at 6 bar 12 m. Spray angle 45°. Spray cone flat. Flow volume at 6 bar: 130l/min.	75	579800985
	<b>Hard jet nozzle AWG TT, Turbo Twist</b>	Throw distance 6 bar: 25 m, Flow volume at 6 bar: 175l/min., max. permitted operating pressure: 16 bar	80	579800986
	<b>Heavy foam tip S2 TT, Turbo Twist</b>	DIN 16712-3:2015-12, Throw distance 6 bar: 23 m Expansion ratio: 15-fach Flow volume at 5 bar: 200 l/min. Measurements: Ø 70 mm	670	579809034
	<b>Heavy foam tip S4, Turbo-Twist, without shut-off unit</b>	DIN 16712-3:2015-12 Throw distance 6 bar: 26 m Expansion ratio: 15-fach Flow volume at 5 bar: 400 l/min. Measurements: Ø 90 mm	760	579800988







## NOZZLES

Product	Name	Description	Length (mm)	Part no.
	<b>Medium foam tip M2, Turbo-Twist, without shut-off</b>	Inlet TT, Flow volume 200 l/min at 5 bar, Throw distance 8 m at 6 bar, Expansion ratio M=50-60	450	579805828
	<b>Medium foam tip M4, Turbo-Twist, without shut-off</b>	DIN 14366. Throw distance 6 bar: 10 m. Expansion ratio: 50-60fach. Flow volume 5 bar: 400 l/min. Ø 265 mm.	540	579800990
	<b>Combination foam branch pipe S4/ M4, Turbo-Twist, switchover device</b>	Throw distance 5bar: S=27/M=8m, Flow volume at 5 bar: 400l/min, Measurements: Ø 265 mm	570	579800991
	<b>Combination foam branch pipe S2/ M2, Turbo-Twist, switchover device</b>	Throw distance 5bar: S=16/M=7m, Flow volume at 5 bar: 200l/min, Measurements: Ø 194 mm	510	579806714
	<b>Foam nozzle Venturi S/M Turbo-Twist, switchover device</b>	Throw distance Medium/low expansion foam: ca. 4/10 m, Proportioning rate btw. 0-3%, Expansion ratio 12-50, Flow at 6 bar: 75 l/min	502	579808410
	<b>Foam nozzle Venturi Turbo- Twist 75</b>	Throw distance 6 bar: Hard jet 19 m, Spray jet 4 m. Flow volume 75 l/min. Proportioning rate: 0, 0,5, 1, 3%	195	579800995
	<b>Foam nozzle Venturi Turbo- Twist 130</b>	Flow volume 130 l/min. Proportioning rate: 0, 0,1, 0,5, 1%		579815306
	<b>Medium foam tip M 0,4 TT, Turbo-Twist</b>	Throw distance 6 bar: 3-5 m. Proportioning rate: 3%. Expansion ratio: 40-50fach. Flow volume at 5 bar: 40 l/min.	502	579800987

**NOZZLES**

Product	Name	Description	Length (mm)	Part no.
	<b>Medium foam pistol AWG M 0,4, Storz C</b>	Throw distance: ca. 6 m, Flow/ 4 bar: 35 l/min, Proportioning rate: 1/3%, Expansion ratio > 60, max. Operating pressure: 16 bar, self-priming	505	579809603
	<b>Foaming agent - additional container AWG, 2 l</b>	Wide-mouth bottle with screw cap (PE)		579800905
	<b>Piercing applicator</b>	Connection system Storz Inlet Storz/ C	1600	579800999
	<b>Firefighting system for fog, complete</b>	Content included: 1x Piercing applicator Attacke, 550 mm 2x Piercing applicator Weitwinkel, 550 mm 1x Special hammer 1x Triple distributor 1x Firebox® size 1 (600x400x220mm) with special insert made from waterproof wood 3x D-hose, Length 10 m		579803176



## MONITORS

Product	Name	Description	Part no.
	<b>Monitor APF 2-Turbo-Fighter</b>	Flow at 8 bar: 2000 l/min, Inlet: Storz B, Outlet: 2 1/2" thread, Swivel range Horizontal/Vertical: $\pm 40^\circ$ / $+20^\circ$ to $+60^\circ$ , max. Operating pressure: 16 bar	579816158
	<b>Monitor APF 2-Turbo-Fighter OSZI</b>	Flow at 8 bar: 2000 l/min, Inlet: Storz B, Outlet: 2 1/2" Thread, Equipment: horizontal, oscillating unit (symmetrical $\pm 30^\circ$ ), Swivel range Horizontal/Vertical: $\pm 30^\circ$ / $+20^\circ$ to $+60^\circ$ , max. Operating pressure: 16 bar	579816548
	<b>Monitor APF 2-Turbo-Fighter MZV 2000/600 EVO</b>	Flow at 8 bar: 600-2000 l/min adjustable in steps of 200, Inlet: Storz B, Outlet: MZV 2000/600 EVO Nozzle, Swivel range Horizontal/Vertical: $\pm 40^\circ$ / $+20^\circ$ to $+60^\circ$ , max. Operating pressure: 16 bar	579801017
	<b>Monitor APF 2-HH XL</b>	Flow at 8 bar: 2000 l/min, Inlet: Storz B, Outlet: 2 1/2" Thread, Swivel range Horizontal/Vertical: $\pm 30^\circ$ / $+25$ to $+90$ , max. Operating pressure: 16 bar	579801002

## MONITORS

Product	Name	Description	Part no.
<b>ACCESSORIES MONITORS</b>			
	<b>Multi-purpose nozzle MZV 1200/500 EVO, G2 1/2"</b>	Flow at 8 bar: 500-1200 l/min adjustable in steps of 100	579816549
	<b>Multi-purpose nozzle MZV 2000/600 EVO, G2 1/2"</b>	Flow at 8 bar: 600-2000 l/min adjustable in steps of 200	579805622
	<b>Multi-purpose nozzle MZ 3000 EVO, G2 1/2"</b>	Flow at 8 bar: 3000 l/min, factory default setting at 2000 l/min	579815805
	<b>Multi-purpose nozzle MZV 3000, G2 1/2"</b>	Flow at 8 bar: 200-3000 l/min adjustable in steps of 200	579809091
without image	<b>Foam nozzle SW 16-8, G2 1/2"</b>	Flow at 8 bar: 1600 l/min	579808841
	<b>Foam nozzle SWS 12-8 G2 1/2"</b>	Flow at 8 bar: 1200 l/min, Foam liquid inlet Storz D with Ball valve, Proportioning rate: 1/2/3/6 %	579815806
	<b>Foam nozzle SWS 16-8 G2 1/2"</b>	Flow at 8 bar: 1600 l/min, Foam liquid inlet Storz D with Ball valve, Proportioning rate: 1/2/3/6 %	579801019
	<b>Foam nozzle SWS 20-8 G2 1/2"</b>	Flow at 8 bar: 2000 l/min, Foam liquid inlet Storz C with Ball valve, Proportioning rate: 1/2/3/6 %	579808889

## MONITORS





Product	Name	Description	Part no.
	<b>Foam nozzle add-on for MZ/MZV Evo</b>	Foam nozzle add-on with self-locking bayonet, suitable for: MZV 1200/500 EVO, MZV 2000/600 EVO, MZ 3000 EVO	579809949
	<b>Foam nozzle add-on SWA 2000-3000</b>	Foam nozzle add-on with self-locking bayonet, suitable for: MZ 2000, MZ 3000, MZV 3000	579816550
	<b>Floor rack for Monitor HH 1260</b>	Quick and simple plug connection between base unit and floor rack. Both are foldable to save space.	579801003
without image	<b>Roof flange for Monitor HH 1260</b>	Easy mounting on vehicle roof with additional available roof flange	579801004



# FIRE EXTINGUISHING EQUIPMENT



## STIRRUP & EXTINGUISHING BACKPACK PUMPS AND FIRE BUCKET

Product	Name	Description	Weight (kg)	
	<b>Stirrup pump AWG A10, DIN</b>	Double-acting piston pump for reliable function. Used for incipient fires of fire Class A with extinguishing agents/water or other aqueous solutions. Tank empties within less than a minute.	8,1	579800900
	<b>Dönges Extinguishing backpack ERMAK</b>	- Easy handling through double-acting pump nozzle - Pump with metal nozzle to select between hard and spray jet - Addtl. Foam nozzle can be added (included) - Isolates firefighter back from cold water - Adjustable straps - Flow volume: 3,7 l/min up to 8,5 m reach, hose length 100 cm - Tank volume 16 l	2,4	579805185
		Tank volume 20 l		579805183
		Tank volume 20 l incl. connector for filling system		579808924
		Tank volume 25 l		579805184
<b>ACCESSORIES</b>				
	<b>Water connection for extinguishing backpack with filling system</b>	Fitted with quick coupling to refill backpack without setting it down.	0,5	579808794
	<b>Fire bucket canvas</b>	Fire bucket made of canvas. Volume 10 l. Incl. handle and spout.	0,1	579802920



# ROBUST CARRIER SYSTEM TO TRANSPORT HEAVY LOADS

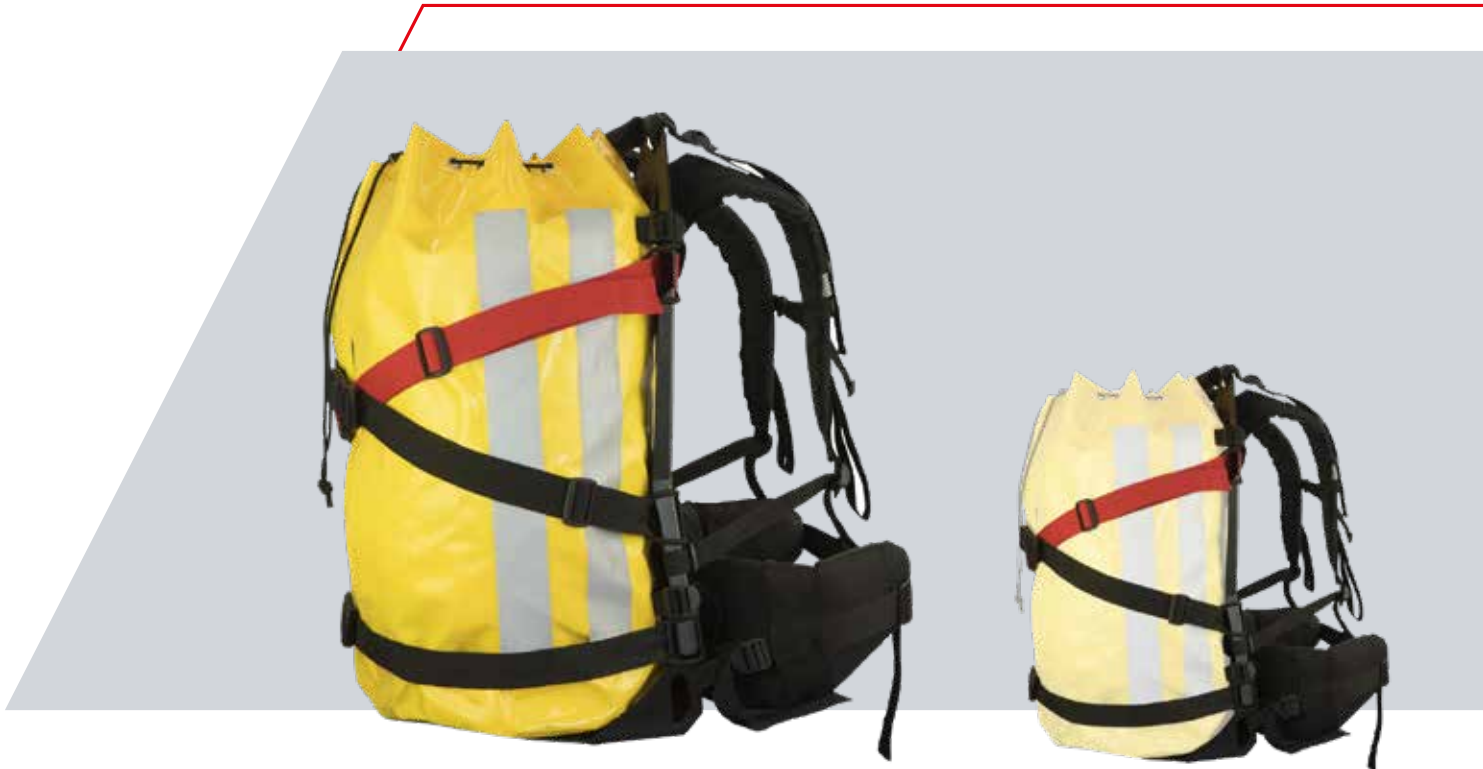

## BENEFITS

- Many times, emergency vehicles cannot reach the deployment site. Instead, heavy equipment and tools need to be carried
- A comfortable extinguishing backpack is an important tool for emergency personnel working close to heavily forested areas, in mountain rescue forces or during major events
- The robust frame with platform of 28,5 cm depth offers a multitude of options to transport hoses, tanks, pumps, tools, emergency medicine etc.
- An anatomically shaped back panel with padding and breathable mesh fabric plus extra wide shoulder and hip straps offer the highest degree of comfort

## CHARACTERISTICS

- Extra wide shoulder and hip straps
- anatomically shaped back panel with lumbar support
- Straps and back panel are padded and made of breathable mesh fabric
- Highly robust aluminium frame
- Adjustable strap system adapts to nearly every user

## SCOPE OF DELIVERY







- 1 aluminium frame
- 1 harness with padding
- 1 nylon strap
- 1 equipment bag, yellow (only incl. with Part no. 579816375)

Part no.	579816375	(incl. bag)
	579816108	(excl. bag)



## HIGH PRESSURE FIRE-EXTINGUISHING DEVICES

Product	Name	Description	Weight (kg)	Part no.
	<b>High pressure fire device MÜLLER WATERJET frame-version</b>	With high-pressure pump, adjustable pressure control valve 40-220 bar and pressure gauge, ejector foam proportioner, high-pressure hose on reel incl. extinguishing pistol. Engine: 9.5 kW (13 HP), pump capacity: 20 l/min, 30 m.	88	579819716
	<b>Bearing module TS 8 for MÜLLER WATERJET</b>		12,5	579819717
	<b>Manway</b>	2 castors, 1 steering castor with parking brake and drawbar for bearing modules or high-pressure extinguishing unit POWERJET.	10,5	579819718
	<b>High pressure fire-extinguisher HiPRESS 9 Carbon</b>	Compressed air: 2 l/300 bar/CFK, operating pressure: 38 bar, duration: 18 sec, jet width: up to 21 m.	9,5	579808522
	<b>High pressure fire-extinguisher HiPRESS VARIO 9 Carbon</b>	Compressed air: 2 l/300 bar/CFK, operating pressure: 38 bar, duration: up to 39 sec, jet width: up to 21 m, rating 55 A + 13 A, 233 B.	10,5	579808524
	<b>High pressure fire-extinguisher HiPRESS VARIO 13 Carbon</b>	Compressed air: 2 l/300 bar/CFK, operating pressure: 38 bar, duration: up to 51 sec, jet width: up to 21 m, rating 2 x 55 A, IV B.	10,5	579808523





## HIGH PRESSURE FIRE-EXTINGUISHING DEVICES

Product	Name	Description	Weight (kg)	Part no.
	<b>High pressure fire-extinguisher HI-PRESS 50</b>	Compressed air: 6,8 l/300 bar, operating pressure: 34 bar, duration: ca. 86 sec, jet width: up to 18 m.	70	579800801
	<b>High pressure fire-extinguisher coldmetal 50</b>	Compressed air: 6,8 l/300 bar, operating pressure: 34 bar, duration: ca. 86 sec, jet width: up to 18 m.	70	579800803
	<b>Compressed air bottle HNE 2 l, 300 bar, steel</b>		5	579805438
	<b>Compressed air bottle HNE 2 l, 300 bar, carbon</b>		3	579809346
	<b>High-performance fire extinguisher MicroCAFS MC6SP10</b>	Flow volume wet/dry 11/5,4 l/min., duration wet/dry 55/115 s. Reach wet/dry 11,5/8 m.	22,5	579801256
	<b>Back carrying platform for compressed air foam generator MicroCAFS 6SP10</b>	Carrying platform incl. padded shoulder & waist belt.	1,1	579816376
without image	<b>Shoulder strap for compressed air foam generator MicroCAFS 6SP10</b>		0,3	579816377





## HIGH PRESSURE FIRE-EXTINGUISHING DEVICES

Product	Name	Description	Weight (kg)	Part no.
	<b>High-performance fire extinguisher</b> <b>MicroCAFS MC6SP50S</b>	Flow volume wet/dry 23/7,7 l/min., duration wet/dry 130/390 s. Reach wet/dry 15/9 m.	95	579801257
	<b>Compressed air bottle</b> 2 l / 300 bar for Micro-CAFS MC6SP10	With valve, incl. pressure gauge.	4,7	579806533
	<b>Extinguishing agent</b> F-15 HNE AFFF 6 % 0,6 l		0,7	579807239

## FIRE EXTINGUISHER MAGIRUS



Product	Name	Description	Weight (kg)	Part no.
	<b>Powder extinguisher with bracket GP-2x ABC</b>	According to DIN EN 3, rating 13A 89B C, temperature range: -30 °C / +60 °C, propellant N2, with bracket.	3,5	579819245
	<b>Powder extinguisher with bracket GP-6x ABC/MP</b>	According to DIN EN 3, rating 43A 233B C, temperature range: -30 °C / +60 °C, propellant: N2, with bracket.	9,7	579819246
	<b>Powder extinguisher with bracket GP-6x ABC/MP Plus</b>	According to DIN EN 3, rating 55A 233B C, temperature range: -30 °C / +60 °C, propellant: N2, with bracket.	9,7	579819248
	<b>Powder extinguisher with bracket GP-9x ABC/MP</b>	According to DIN EN 3, rating 55A 233B C, temperature range: -30 °C / +60 °C, propellant: N2, with bracket.	14	579819249
	<b>Powder extinguisher with bracket GP-12x ABC/MP</b>	According to DIN EN 3, rating 43A 233B C, temperature range: -30 °C / +60 °C, propellant: N2, with bracket.	19	579819250
	<b>CO<sub>2</sub> extinguisher with bracket GS-2x B</b>	According to DIN EN 3, rating 34B, temperature range: -20 °C / +60 °C.	7	579819251

## FIRE EXTINGUISHER MAGIRUS

Product	Name	Description	Weight (kg)	Part no.
	<b>CO<sub>2</sub> extinguisher with bracket GS-5x B/MP</b>	According to DIN EN 3, rating 89B, temperature range: -20 °C / +60 °C.	14	579819252
	<b>Foam-Extinguisher Magirus GPN-6x AB/MP Plus</b>	According to DIN EN 3, rating 27A 183B, temperature range: 0 °C / +60 °C, propellant: N2, with bracket.	9,3	579819361
	<b>Foam-Extinguisher Magirus GPN-9x AB/MP</b>	According to DIN EN 3, rating 27A 233B, temperature range: +5 °C / +60 °C, propellant: N2, with bracket.	14	579819362
	<b>Water-Extinguisher Magirus GW-6x A/MP</b>	According to DIN EN 3, rating 13A, temperature range: +5 °C / +60 °C, propellant: N2, with bracket.	9,3	579819364
	<b>Water-Extinguisher Magirus GW-9x A/MP</b>	According to DIN EN 3, rating 21A, temperature range: +5 °C / +60 °C, propellant: N2, with bracket.	14	579819365

FIRE EXTINGUISHING EQUIPMENT

## FIRE EXTINGUISHER MAGIRUS





Product	Name	Description	Weight (kg)	Part no.
	<b>Powder extinguishing Magirus Magirus AP-25x ABC</b>	Corresponds to DIN EN 1866-1, rating A II B C, temperature range -20 to +60 °C, propellant: N <sub>2</sub> , extinguishing agent 25 kg.	48	579819369
	<b>Powder extinguishing Magirus Magirus AP-50x ABC</b>	Corresponds to DIN EN 1866-1, rating A III B C, temperature range -30 to +60 °C, propellant: N <sub>2</sub> , extinguishing agent 50 kg.	85	579819370
	<b>CO<sub>2</sub> extinguishing Magirus Magirus AS-30x B</b>	Corresponds to DIN EN 1866-1, rating 113B, temperature range -20 to +60 °C, propellant: 30 kg CO <sub>2</sub> .	98	579819371

## FIRE EXTINGUISHER

Product	Name	Description	Weight (kg)	Part no.
	<b>Fire extinguisher Minimax PU 2 G DE/EN</b>	Rating: 13A, 89B, C, LE 4, with car cradle, build PG 2 L, stored pressure extinguisher, filled with 2 kg ABC extinguishing powder, incl. car cradle.	3,5	579800645
	<b>Fire extinguisher Minimax Powder PU 6 G DE</b>	EN 3, rating 43 A/233 B+C, LE12, enclosed CO <sub>2</sub> bottle, build PG6H, charger, filled 6 kg EURO-TROXIN S(ABC), without wall mount.	10,9	579800635
	<b>Fire extinguisher Minimax Powder PU 9 G DE</b>	EN 3, rating: 43 A, 183 B & C, LE 12, enclosed CO <sub>2</sub> bottle, build PG 9 H, charger, filled with 9 kg EURO-TROXIN S (ABC), without wall mount.	14,9	579800637
	<b>Fire extinguisher Minimax Powder PU 12 G DE</b>	EN 3, rating 55 A 233 B C, LE 15, enclosed CO <sub>2</sub> bottle, build PG 12 H, charger, filled 12 kg EURO-TROXIN S (ABC), without wall mount.	18,9	579800638
	<b>Fire extinguisher Minimax Foam WX 6 nG green, DE</b>	EN 3, rating 34 A,183 B, LE 10, enclosed CO <sub>2</sub> bottle, with integrated NFC chip, squeeze grip valve (impact-resistant high-performance plastic), charger, filled with 5,91 l aqueous solution + 1 x tube 0,09 l AFFF concentrate, not frost-proof, recognition no. SP 96/16, without wall mount.	11,4	579800639
	<b>Fire extinguisher Minimax Grease fire WF 3 nG DE</b>	Rating: 13 A, 70 B and 40 F, LE 4, enclosed CO <sub>2</sub> bottle. Build W 3 H-0, charger, filled with 3 l Meterin-2, without wall mount.	6,8	579800642
	<b>Fire extinguisher Minimax Grease fire WF 6 nG DE</b>	Rating 21 A, 113 B and 75 F, LE 6, enclosed CO <sub>2</sub> bottle. Build W 6 H-0, charger, filled with 6 l Meterin-2, without wall mount.	11,5	579800643





## FIRE EXTINGUISHER

Product	Name	Description	Weight (kg)	Part no.
	<b>Fire extinguisher Minimax metal fire PM 12i DE</b>	To fight metal fires, enclosed CO <sub>2</sub> bottle, build PM 12 H, charger, filled with 12 kg META-TROXIN (D).	20	579800644
	<b>Fire extinguisher Minimax Carbon dioxide CS 2c DE</b>	Rating 34 B, LE 2, steel bottle, snow horn, filled with 2 kg carbon dioxide (B).	5,9	579800646
	<b>Fire extinguisher Minimax Carbon dioxide CS 5c DE</b>	DIN EN 3 SP 18/06, rating 89 B LE 5, steel bottle, build K 5, filled with 5 kg carbon dioxide (B).	14	579800647
	<b>Fire extinguisher Minimax Carbon dioxide C 30</b>	DIN EN 1866, 30 kg CO <sub>2</sub> , class: 3x144, 6 m hose, throw distance: ca. 3 m.	92	579805591
	<b>Fire extinguisher Minimax Powder PU 50s</b>	DIN EN 1866, 50 kg ABC extinguishing powder. Class: A/IV B/C, 5 m hose, operational period: ca. 60s.	92	579805590

### ACCESSORIES FIRE EXTINGUISHER

	<b>Car cradle for all 6 kg /6 l fire extinguisher minimax</b>		1,27	579800636
	<b>Car cradle for all 9 + 12 kg/l fire extinguisher minimax</b>		1,24	579800641
	<b>Car cradle for 5 kg fire extinguisher minimax</b>		1,26	579800648

## FIRE EXTINGUISHER

Product	Name	Description	Weight (kg)	Part no.
	<b>Special fire extinguisher Sion Hydrofix A 10/L, 10 l</b>	According EN 3 for fire classes A and B, rating 34 A, 233 B (with extinguishing agent), piercing applicator 400 mm with nozzle.	17,5	579805540
	<b>Special fire extinguisher Sion Hydrofix B 5/L</b>	According EN 3 for fire classes A and B, rating 27 A, 144 B (with extinguishing agent), piercing applicator 270 mm with nozzle.	8,5	579805560

ACCESSORIES FOR FIRE EXTINGUISHER SION				
	<b>Filling fitting Hydrofix</b>	20-22 bar, with pressure gauge, security, ventilation, and connection valve. Filling hose 1.000 mm incl. plug nipple.	1	579805561
without image	<b>Piercing applicator Hydrofix</b>	For B 5 and A 10 when extinguishing through small opening – optional equipment available.	0,8	579805917
	<b>Carrying straps</b>	For Hydrofix A 10.	0,3	579806396

# THE INNOVATIVE SYSTEM FOR SECURING AND RECOVERING ELECTRIC VEHICLES



## CHARACTERISTICS





- Simple and intuitive one-way quarantine system for electric vehicles after a fire incident
- Low water consumption through adaptation to the vehicle contour (all common types of cars)
- Suitable for filling with extinguishing water
- Mobile and inexpensive alternative to roll-off containers
- Roll the vehicle in, lift it or, in tight spaces (underground garages, courtyards, ...), lift it on both sides and undergo
- The vehicle can be handed over to the tow truck, secured in the system
- Contaminated water is retained and can be disposed of properly
- Easy to transport and easy to store
- The best solution for fire brigades, towing companies, workshops and car dealerships

## CONTENT

- 1x Recover-E-Bag
- 1x Recover-E-Training-Bag (not for operation!)
- 2x Tension belt 2000 daN with claw hook, blue (4 m)
- 2x Tension belt 2000 daN with claw hook, green (4 m)
- 1x Tension belt 2000 daN with claw hook, yellow (6 m)
- 1x Lashing strap 2000 daN with claw hook, red (6 m)
- 1x Lashing strap 2000 daN with claw hook, orange (8 m)
- 4x Sling 715 daN with snap hook, black (0,6 m)
- 4x Anti-slip mat
- 1x Transport box for accessories
- 1x Transport bag for Recover-E-Bag
- 1x Instruction manual



## FIRE BLANKETS

Product	Name	Description	Length (mm)	Width (mm)	Part no.
	<b>Fire blanket ultraFIRE I</b>	Fire blanket from glass fabric, DIN 1869.	1800	1600	579801731
	<b>Fire blanket ultraFIRE III</b>	Fire blanket from glass fabric, DIN 1869 with bag.	1600	1800	579801733
	<b>Fire blanket ultraFIRE IV</b>	EN 1869, from glass fabric with pocket grips, in plastic box, red-white.	1200	1200	579816385
	<b>Fire blanket Nomex</b>	Incombustible. Soft, light, smooth. Non melting or dripping, resistant to chemicals, skin-friendly.	1600	2000	579806028
	<b>Ever-ready bag for firefighters</b>	High visibility through conspicuous colours and clearly visible pictogram with print 'fire blanket'.	300	120	579806794

# THE SIMPLE YET EFFECTIVE SOLUTION TO CONTAIN A CAR FIRE





## CHARACTERISTICS

- Suffocates fire and therefore prevents expansion of car fire
- Prevents fire from reaching other cars or close-by building structures
- Effective to stop smoke and fume development
- Effective to limit damages due to car fires
- Makes it easier for firefighters to control seat of fire upon arrival. Minimum of extinguishing agents required
- LEADER Stop withstands high temperatures up to 1000 °C (Material: glass fibre with silicon coating)
- Large size (LxW) 6x8 m / Packing size (LxWxH) 830x340x270 mm, approx. 25 kg
- Easy and quick covering of car thanks to flexible and highly robust fabric
- Re-useable (depending on deployments and hygiene of deployment site/decontamination procedures)











Car fire blanket LEADER STOP, with case  
Car fire blanket LEADER STOP, without case

Part no. 579809990  
Part no. 579816386

## FOAM FITTINGS

Product	Name	Description	Length (mm)	Part no.
 	<b>Foam nozzle S4/M4, AWG, with shut-off unit</b>	DIN 16712-3, Storz B, flow volume at 5 bar: 400 l/min, throw distance low expansion/medium foam: ca 27/8 m.	665	579800901
	<b>Foam nozzle S2/M2, AWG, with shut-off unit</b>	DIN 16712-3, Storz C, Flow volume at 5 bar: 200 l/min, Throw distance low expansion/medium foam: ca 16/7 m.  <b>Other coupling-systems on request.</b>	610	579804379
 	<b>Foam nozzle M4, AWG, with shut-off unit</b>	DIN 16712-3, Storz B, Flow volume at 5 bar: 400 l/min, Throw distance: approx. 12 m, expansion ratio: 50-70.	630	579800902
	<b>Foam nozzle M2, AWG, with shut-off unit</b>	DIN 16712-3, Storz C, Flow volume at 5 bar: 200 l/min, Throw distance: approx. 8 m, expansion ratio: 50-70.  <b>Other coupling-systems on request.</b>	533	579804276
  	<b>Foam nozzle S4 AWG, with shut-off unit</b>	DIN 16712-3, Storz B, Flow volume at 5 bar: 400 l/min, Throw distance: approx. 26 m.	866	579800903
	<b>Foam nozzle S2 AWG, with shut-off unit</b>	DIN 16712-3, Storz C, Flow volume at 5 bar: 200 l/min, Throw distance: approx. 23 m.	738	579804278
	<b>Foam nozzle S8 AWG, with shut-off unit</b>	DIN 16712-3, Storz B, Flow volume at 5 bar: 800 l/min, Throw distance: approx. 36 m.  <b>Other coupling-systems on request.</b>	975	579800906
 	<b>Foam inductor Z2R „light“, AWG</b>	DIN 14384, in-/outlet C fixed coupling. Foaming agent inlet D fixed coupling. Mixture flow volume 200 l/min.	370	579804279
	<b>Foam inductor AWG Z2 FD</b>	DIN EN 16712, precision dosing, in-/outlet C-Fixed coupling. Foaming agent inlet D-fixed coupling. Mixture flow volume 200 l/min.  <b>Other coupling-systems on request.</b>	294	579805665
 	<b>Foam inductor Z4R „light“, AWG</b>	DIN 14384, in-/outlet 2 x B. Mixture flow volume 400 l/min.	355	579800907
	<b>Foam inductor AWG Z4 FD</b>	DIN 14384, precision dosing, in-/outlet B-Fixed coupling. Foaming agent inlet D-fixed coupling. Mixture flow volume 400 l/min.  <b>Other coupling-systems on request.</b>	294	579804892
	<b>Foam inductor Z8R „light“, AWG</b>	DIN 14384, in-/outlet 2 x B mixture flow volume 800 l/min.  <b>Other coupling-systems on request.</b>	355	579800908

## FOAM FITTINGS

Product	Name	Description	Length (mm)	Part no.
<b>ACCESSORIES FOAM INDUCTOR</b>				
	<b>Foam inductor add-on AWG Z-Select</b>	Connector on both sides Storz D, diameter 64 mm.  <b>Other coupling-systems on request.</b>	142	579800968
	<b>Suction hose</b>	DIN EN 16712-2, one side Storz D, other side with indentation.	1500	579800909
	<b>Suction hose</b>	Both sides Storz D.	1500	579804870
	<b>Suction hose</b>	One side Storz D, other side with stainless-steel pipe 1 m.  <b>Other coupling-systems on request.</b>	2000	579805207
<b>FOAM INDUCTOR LEADER MIX</b>				
	<b>Foam inductor LEADER Mix 200-1000 l/min portable</b>	Precise dosing of foaming agent from 0,3-6 % starting at 5 bar, flow volume from 200 up to 1050 l/min (proportioning rate 3 %), in-/outlet Storz B, foaming agent inlet Storz D incl. suction hose with immersion pipe 2,5 m.  <b>Other coupling-systems on request.</b>	486	579809537
	<b>Foam inductor LEADER Mix 200-1000 l/min Vehicle installation</b>	Precise dosing of foaming agent from 0,3-6 % starting at 5 bar, flow volume from 200 up to 1050 l/min (proportioning rate 3 %), in-/outlet 2 1/2" IG, foaming agent inlet 1" AG.  <b>Other coupling-systems on request.</b>	486	579816387
	<b>Foam inductor LEADER MIX 400 FIBERTECH 400 l/min, 6 bar, B-Storz</b>	The LEADER MIX 200 and 400 offers a variety of concentrations thanks to its large dispensing valve: 0,1 – 0,25 – 0,5 – 1 – 2 – 3 – 4 – 5 or 6 %.  <b>Other coupling-systems on request.</b>	390	579816389
	<b>Foam inductor LEADER MIX 400 FIBERTECH 400 l/min, 6 bar, C-Storz</b>	Same description as 579816389 only different version.  <b>Other coupling-systems on request.</b>	390	579809714
	<b>Foam inductor LEADER MIX 200 FIBERTECH 200 l/min, 6 bar, C-Storz</b>	Same description as 579816389 only different version.  <b>Other coupling-systems on request.</b>	390	579816388

## FOAMING AGENTS DR. STHAMER



Product	Name	Description	Weight (kg)	Part no.
   	<b>Multi-use Foaming agent STHAMEX 3 % F-15, 20 l</b>	EN 1568 part 1, 2 and 3, IMO 670, proportioning rate 3 %, wetting agent 0,5 %.	20	579815749
	<b>Multi-use Foaming agent STHAMEX 3 % F-15, 60 l</b>	EN 1568 part 1, 2 and 3, IMO 670, proportioning rate 3 %, wetting agent 0,5 %.	60	579815750
	<b>Multi-use Foaming agent STHAMEX 3 % F-15, 210 l</b>	EN 1568 part 1, 2 and 3, IMO 670, proportioning rate 3 %, wetting agent 0,5 %.	210	579815751
	<b>Multi-use Foaming agent STHAMEX 3 % F-15, 1000 l</b>	EN 1568 part 1, 2 and 3, IMO 670, proportioning rate 3 %, wetting agent 0,5 %.	1040	579815752
   	<b>Foaming agent ST-HAMEX-Class A 0,5 % F-15, 20 l, synthetic</b>	EN 1568 part 1 and 3, fluorine-free, proportioning rate: Class A: 0,3-0,5 %, Class B: 0,5-1 %, wetting agent 0,1 %.	20	579802044
	<b>Foaming agent ST-HAMEX-Class A 0,5 % F-15, 60 l, synthetic</b>	EN 1568 part 1 and 3, fluorine-free, proportioning rate: Class A: 0,3-0,5 %, Class B: 0,5-1 %, wetting agent 0,1 %.	60	579802045
	<b>Foaming agent ST-HAMEX-Class A 0,5 % F-15, 210 l, synthetic</b>	EN 1568 part 1 and 3, fluorine-free, proportioning rate: Class A: 0,3-0,5 %, Class B: 0,5-1 %, wetting agent 0,1 %.	210	579802046
	<b>Foaming agent ST-HAMEX-Class A 0,5 % F-15, 1000 l, synthetic</b>	EN 1568 part 1 and 3, fluorine-free, proportioning rate: Class A: 0,3-0,5 %, Class B: 0,5-1 %, wetting agent 0,1 %.	1040	579802047



## FOAMING AGENTS DR. STHAMER

Product	Name	Description	Weight (kg)	Part no.
   	<b>Foaming agent ST-HAMEX-Class A Classic 1 % 20 l, synthetic</b>	EN 1568 part 1 and 3, fluorine-free, biodegradable, proportioning rate: Class A 0,5 % - 1,0 %, Class B 1 %, wetting agent 0,1 - 0,3 %.	20	579802048
	<b>Foaming agent ST-HAMEX-Class A Classic 1 %, 60 l, synthetic</b>	EN 1568 part 1 and 3, fluorine-free, biodegradable, proportioning rate: Class A 0,5 % - 1,0 %, Class B 1 %, wetting agent 0,1 - 0,3 %.	60	579802049
	<b>Foaming agent ST-HAMEX-Class A Classic 1 %, 210 l, synthetic</b>	EN 1568 part 1 and 3, fluorine-free, biodegradable, proportioning rate: Class A 0,5 % - 1,0 %, Class B 1 %, wetting agent 0,1 - 0,3 %.	210	579802050
	<b>Foaming agent ST-HAMEX-Class A Classic 1 %, 1000 l, synthetic</b>	EN 1568 part 1 and 3, fluorine-free, biodegradable, proportioning rate: Class A 0,5 % - 1,0 %, Class B 1 %, wetting agent 0,1 - 0,3 %.	1040	579802051
   	<b>Foaming agent STHA-MEX-AFFF 6 % F-15, 20 l, synthetic</b>	EN 1568 part 1 and 3, ICAO Level B, IMO, MED, water film forming, proportioning rate: 6 %.	20	579802056
	<b>Foaming agent STHA-MEX-AFFF 6 % F-15, 60 l, synthetic</b>	EN 1568 part 1 and 3, ICAO Level B, IMO, MED, water film forming, proportioning rate 6 %.	60	579802057
	<b>Foaming agent STHA-MEX-AFFF 6 % F-15, 210 l, synthetic</b>	EN 1568 part 1 and 3, ICAO Level B, IMO, MED, water film forming, proportioning rate 6 %.	210	579802058
	<b>Foaming agent STHA-MEX-AFFF 6 % F-15, 1000 l, synthetic</b>	EN 1568 part 1 and 3, ICAO Level B, IMO, MED, water film forming, proportioning rate: 6 %.	1040	579802059

**FOAMING AGENTS BIOEX**

Product	Name	Description	Volume (l)	Part no.
	<b>Foaming agent BIO FOAM 15</b>	DIN EN 1568-1-2-3:2018, 2013-F-1877/Bio 08, IMO licenced, totally biodegradable, multi-use foaming agent 2-6 %, fire classes: A, B, frost-resistant up to -15 °C, fluorine-free.	20 60 200 1000	579816215 579816393 579816394 579816395
	<b>Foaming agent BIO FOR N</b>	DIN EN 1568-1-2-3:2018, PL-11/02, totally biodegradable, wetting capability 0,1-0,5 %, foaming capability 0,5-1 %, fire classes A, B, frost-resistant up to -10 °C, fluorine-free.	20 60 200 1000	579807137 579816390 579809571 579816392
	<b>Foaming agent BIO FOR C</b>	DIN EN 1568-1-2-3:2018, PL-5/02, totally biodegradable, wetting capability 0,1-0,3 %, foaming capability 0,3-0,5 %, fire classes A, B, frost-resistant up to -15 °C, fluorine-free.	20 60 200 1000	579816396 579816397 579816398 579816399

FIRE EXTINGUISHING EQUIPMENT

**LEADER®**

Fighting for performance

**BATFAN 3 LI+**

**BATTERY FAN WITH SWAPPABLE BATTERY**  
50 minutes runtime with one battery  
at full speed of 29,270 m<sup>3</sup>/h (open air flow)

- Adjustable tilt from + 65° to - 90°
- Integrated variable-speed drive
- Illumination of the ventilation zone with 10 LEDs
- Built in charger: charge during operation
- Extremely Robust
- Ready for use even in the harshest environments - IP66
- Works with battery and/or plugged to the main power
- On mains power, the battery is charged at the same time



- **Robust and lightweight (23.5kg):** for self-contained operation!
- **Compact, mobile and low noise level**
- **Ready for use immediately and everywhere**
- **More flexibility with swappable lithium-ion battery pack**

Multi-use thanks to the optional accessories:  
Blowing or suction ducts, high expansion foam adapter  
and rehab misting adaptor.

**WWW.LEADER-GROUP.COMPANY**

## TRANSFER PUMPS

Product	Name	Description	Weight (kg)	Part no.
without image	<b>Pump set F430</b>	Barrel pump F 430 PP-40/33 with mechanical seal, seal material FKM with shaft from Hastelloy C, commutator motor FEM 4070, 230 V, 50 Hz, 500 Watt with speed setting and undervoltage release, PVC hose inlet DN 19, 2 m long, with nozzle and drum screw joint PP (G 2), immersion depth 1000 mm.	1,4	579806030
without image	<b>Pump set F458</b>	Barrel pump F430 PP-40/33 in polypropylene with shaft from Hastelloy C, Mechanical seal, Seal material FKM, with commutator motor F458, 24V DC, 410-Watt, PVC hose inlet DN19, 2 m long, with nozzle PP, immersion depth 1000 mm.	1,4	579805624
	<b>Manual pump K 10 C incl. hose kit</b>	Manual reciprocating pump to extract from barrels and small casks for diesel, fuels (AI-III), heating oil EL/L, low viscosity mineral oils, antifreeze (undiluted).	2,4	579816273
without image	<b>Telescopic suction pipe for manual pump K 10 C</b>	Extendable from 490 - 925 mm.	2,4	579816274

# THE HIGH-PERFORMANCE PORTABLE PUMP MAGIRUS FIRE 1500

With the portable pump FIRE 1500, fire brigades have access to a pump exemplary in form and function. Based on successful predecessors, Magirus developed a portable pump that does justice to 21st century aesthetics, and especially meets the challenges of tough day-to-day firefighter business. Available as an option are various couplings, battery charging devices and plug connections to charge the pump.

## TECHNICAL DATA

- High-performance, water-cooled, quiet and minimised vibrations straight-four engine produced by FPT
- 1.368 ccm and 57 kW (77 PS) at 6.000 U/min
- Fuel tank for 18 l
- Two-staged Magirus centrifugal pump, resistant against waste water and temperature fluctuations, dry run protection, pressure shock resistance
- Housing made of stainless light metal, stainless-steel pump shaft
- Automatic pump ventilation Magirus PRIMATIC
- Closing pressure: 17 bar

## OUTPUT

- 3 m geodetic suction height 1.500 l/min at 10 bar
- 7,5 m geodetic suction height 750 l/min at 10 bar





#### **BENEFITS**

- Maximum security during deployment with a minimum of noise pollution thanks to highest performance during continuous operation with up to 8 m suction height
- Robust stainless-steel frame: light-weight, corrosion-resistant, suitable to attach lifting gear at e.g., helicopter
- 8 permanently mounted, ergonomic rubber handles on all sides enable safe and fast transport
- Measurements according to DIN EN 14466
- Loading onto any vehicle possible through standardized bearing
- Electric starter as standard, additional manual starter device available
- Intuitive control panel bundles all functionalities in one place
- Mechanical coupling between pump and engine





Part no. 579808730

**PORTABLE PUMPS**

Product	Name	Description	Weight (kg)	Part no.
	<b>Portable pump PFPN 10-1500 according to DIN 14466</b>	<p>Motor: water-cooled straight-four engine</p> <ul style="list-style-type: none"> <li>• Electric starter with lead battery 12 V / 20 Ah and additional, emergency manual launcher incl. return prevention, fully integrated in pump enclosure</li> <li>• Performance: 57 kW (77 PS) at 6.000 U/min • Displacement: 1.368 cm<sup>3</sup></li> <li>• Fuel tank for 18 l premium</li> </ul> <p>Centrifugal pump: low-maintenance, two-staged Magirus firefighting centrifugal pump • Stainless steel pump shaft • Output at 3 m Suction height: 1.500 l/min. at 10 bar • Output at 7,5 m Suction height: 750 l/min. at 10 bar • Closing pressure: 17 bar</p> <p>Ventilation system: MAGIRUS „Primatic“ pump ventilation system.</p> <p>Additional features: Carrying structure with tubular frame and ergonomically placed handles at the corners • Locking mechanism to secure portable pump in emergency vehicle (according to standard) • Control panel with all steering and control elements • 12 V charging socket, BEOS, 3 pin • Fan monitoring via acoustic and visual alerts in case of fan malfunction to prevent subsequent damages • Manual</p> <p> <b>Other coupling-systems on request.</b></p>	192 filled up	579808730
	<b>Portable pump PFPN 10-1000 according to DIN 14466</b>	<p>Motor: Water-cooled straight-four engine</p> <ul style="list-style-type: none"> <li>• Electric starter with lead battery 12 V / 20 Ah and additional, emergency manual launcher incl. return prevention, fully integrated in pump enclosure</li> <li>• Performance: 57 kW (77 PS) at 6.000 U/min • Displacement: 1.368 cm<sup>3</sup> • Fuel tank for 18 l premium</li> </ul> <p>Centrifugal pump: low-maintenance, two-staged Magirus firefighting centrifugal pump • Stainless steel pump shaft • Output at 3 m Suction height: - 1350 l/min. at 10 bar • Output at 7,5 m Suction height: - 750 l/min. at 10 bar • Closing pressure: 17 bar</p> <p>Ventilation system: MAGIRUS „Primatic“ pump ventilation system.</p> <p>Additional features: Carrying structure with tubular frame and ergonomically placed handles at the corners • Locking mechanism to secure portable pump in emergency vehicle (according to standard) • Control panel with all steering and control elements • 12 V charging socket, BEOS, 3 pin • Fan monitoring via acoustic and visual alerts in case of fan malfunction to prevent subsequent damages • Manual</p> <p> <b>Other coupling-systems on request.</b></p>	192 filled up	579808478

FIRE EXTINGUISHING EQUIPMENT

## ACCESSORIES PORTABLE PUMPS

Product	Name	Description	Part no.
without image	<b>Equipment</b>	Set of 10 l canister steel with spout and exhaust hose.	579808480
	<b>Spare parts</b>	Set of O-ring DIN 3770, tools incl. extractor, refill bottle for engine oil.	579808481
	<b>Charging socket 12V</b>	According to DIN 14690 (standard socket), 2 pin, to retrofit Magirus portable pump or portable generator.	579808482
	<b>Charging socket Mag-Code</b>	To retrofit Magirus portable pump or portable generator.	579808483
	<b>Ladomat converter 10/30-2 N-T-T, 230V</b>	230 V AC adapter, spiral cords 0,8 m FX30, extendable to 2-2,5 m, with 3 pin male connector and self-locking bayonet (further connectors available upon request).	579816241
	<b>Rolling device Magirus portable pump</b>	Incl. 2 ball bearing mounted wheels, ball bearing mounted swivel castor with wheel lock, drawbar with quick lock, length 800 mm.	579816126
 	<b>Portable pump trailer Magirus TSA 750</b>	Produced according to ISO 9001, CE safety regulations and NSPGV (Low Voltage Electrical regulations). Reversing mechanisms, 13-inch tires, perforated floor plates, MP light system with rear fog lights, 13 pin connector, support wheel with cable clamps, 2 supporting legs with cable clamps, GFK hood opens through gas pressure absorbers, painted red, white design stripes and tactical markings, ball bearing mounted runner for portable pump, mounting section for suction and pressure equipment, interior lighting, 230 V charging socket and charging mount for portable pump.	579817215
without image	<b>Periphery lighting</b>	To illuminate way leading to deployment site. Activation through pressure switch of work lights.	579817178





# TECHNICAL EQUIPMENT



# KEEPING AN EYE ON THE MISSION – THE MAGIRUS M-EYE DRONE

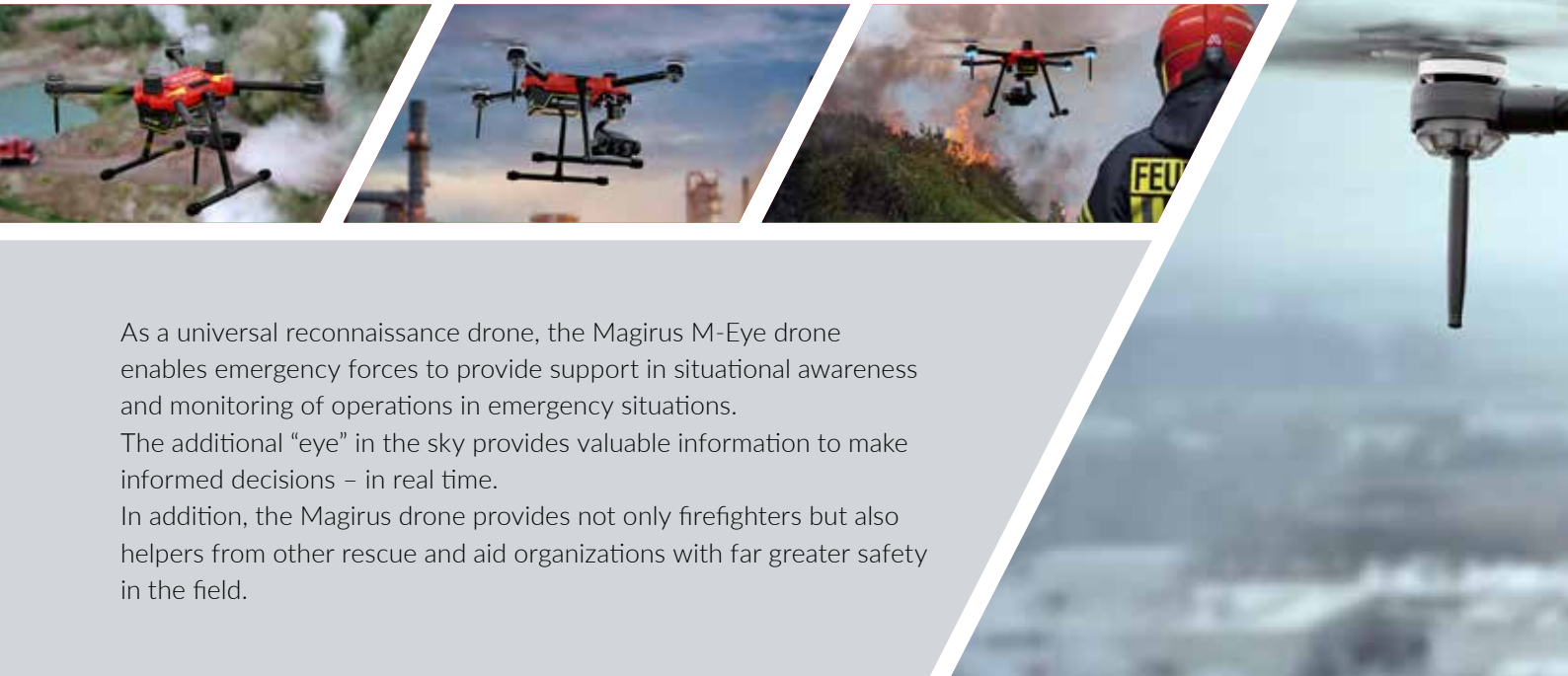

As a universal reconnaissance drone, the Magirus M-Eye drone enables emergency forces to provide support in situational awareness and monitoring of operations in emergency situations.

The additional “eye” in the sky provides valuable information to make informed decisions – in real time.

In addition, the Magirus drone provides not only firefighters but also helpers from other rescue and aid organizations with far greater safety in the field.



#### TECHNICAL DATA:

- Weight: 4000 g
- Maximum payload: 1480 g
- Flight time: 68 min
- Protection class: IP 43
- Positioning: GNSS and Dual RTK

#### Camera

- Resolution: 1080p Full HD
- Zoom: 320x (hybrid)

#### IR camera

- Resolution: 640 x 512, 12µm
- Gimbal: 3 axes FOC

#### Rangefinder

- Measuring range: 5-1500 m







**FEATURES:**

- Camera with AI object identification and tracking with up to 10 objects (vehicles and people).
- Picture-in-picture view for thermal and real images
- Waypoint planning
- Return-To-Home function
- Additional options like lighting system or additional gimbal



## DRONE MAGIRUS

Product	Name	Description	Weight (kg)	Part no.
	<b>Drone Magirus M-Eye</b>	incl. 1 charger, 2 batteries, control incl. integration & programming, hard case	4	579818329
	<b>Camera system A10TR for drone M-Eye</b>	10x optical zoom, 32x digital zoom, thermal function, 8x digital zoom 640x512, operating temperature -20° to +60°C		579819375
without image	<b>LED-Bar for Magirus M-Eye drone</b>	10.000 lm, mechanical fixation on the rotor arm Control via system app		579819162
without image	<b>Charger 350 W for Magirus drone M-eye</b>			579819163
	<b>Landing linkage for Magirus M-Eye drone</b>	spare part		579819763
	<b>Rotor blades for Magirus M-Eye drone</b>	spare part		579819764
	<b>Landing-Pad for Magirus M-Eye drone</b>	26 eyelets evenly distributed all around		579819762

NEXT GENERATION



# ALWAYS READY FOR OPERATION

With Magirus FLEETCONNECT  digital fleet management

Emergency services must be able to fully rely on their vehicles - everywhere and all the time. With FleetConnect by Magirus, we offer you a perfect, easy to use solution for monitoring and maximising the uptime of your fleet. The digital fleet management system uses intelligent software to increase your operational readiness while reducing administrative work. It supports you with constant real-time transparency of your vehicles. Always and, thanks to the Magirus Cloud, from anywhere in the world. Connect your fleet like never before with Magirus FleetConnect!

More  
about  
Fleet  
Connect



# A RELIABLE SOURCE OF ENERGY WHEN EVERY SECOND COUNTS.

Generator MSE 14 Super Silent lightens the load on fire brigades, relief organisations and disaster prevention units. Constant development of existing technologies makes the MSE 14 Super Silent a reliable source of energy during deployments. It comes equipped according to DIN 14685-1 standard and can be easily customized with additional accessories. Thanks to its built-in DUPLEX generator, electric and inductive devices can be run in parallel.

## FURTHER CHARACTERISTICS:

- „MAGIRUS“ branding
- Ground bond tester
- Insulation monitoring
- Cut-out feature in case of low oil
- ECO Tronic
- Starter battery 12 V/20 A
- Outlets 3x 230V, 2x 400V
- Vehicle tool kit
- Fuel tank 12l
- Emergency stop button
- Sound power level LWA 96 dB(A)
- Overload protection for generator





**HIGHLIGHTS:**

- Foldable handles
- Multi-purpose control panel E-MCS 4.0
- LED lighting for switch board
- Electric starter
- Exhaust system as a customized option available on side of switchbox
- 3-way fuel valve for external refuelling
- 16-pin remote starter (optional)



Briggs & Stratton Vanguard  
Diesel engine  
Nominal capacity 13,7 kVA

## GENERATORS MAGIRUS

Product	Name	Description	Weight (kg)	Measures (mm)	Part no.
	<b>Generator MSE 14 Super Silent Plus</b>	DIN 14685-1. 13,7 kVA. Super soundproof. Duplex. Diesel engine B&S 23 HP. Electric starter. ECO Tronic.	150	820 x440 x580	579800299
without image	<b>Generator MSE 9</b>	DIN 14685-1. 9,0 kVA. Open frame design. Duplex. Diesel engine Briggs & Stratton Vanguard 16 HP. Electric starter. Incl. BEOS charging socket & Votronic temperature sensor	130	820 x440 x580	579808147
	<b>Generator MSE 9 Super Silent</b>	DIN 14685-1. 9,0 kVA. Soundproof. Duplex. Diesel engine Briggs & Stratton Vanguard 16 HP. Electric starter. Incl. Fire-Can interface & Votronic temperature sensor. ECO Tronic. Exhaust system on switchbox side. Suitable for turntable ladder Magirus	130	820 x440 x580	579809020
	<b>Generator MSE 9 Super Silent</b>	DIN 14685-1. 9,0 kVA. Soundproof. Duplex. Diesel engine Briggs & Stratton Vanguard 16 HP. Electric starter. Incl. remote starter Harting plug & Votronic Temperature sensor. ECO Tronic. Exhaust system switchbox side. Suitable for turntable ladder Magirus	130	820 x440 x580	579800297
	<b>Generator MSE 13 Super Silent</b>	DIN 14685-1. 13,2 kVA. Soundproof. Duplex. Diesel engine Briggs & Stratton Vanguard 23 HP. Electric starter. Incl. Fire-Can interface & Votronic temperature sensor. ECO Tronic. Exhaust system switchbox side. Suitable for turntable ladder Magirus	130	820 x440 x580	579816881
	<b>Generator MSE 13 Super Silent</b>	DIN 14685-1. 13,2 kVA. Soundproof. Duplex. Diesel engine Briggs & Stratton Vanguard 23 HP. Electric starter. Incl. remote starter Harting plug & Votronic Temperature sensor. ECO Tronic. Exhaust system switchbox side. Suitable for turntable ladder Magirus	130	820 x440 x580	579805179



# LIGHTWEIGHT, ROBUST, POWERFUL AND FLEXIBLE. INSTAGRID ONE IS THE NEW STANDARD FOR MOBILE WORK.



Our portable battery power supply was designed specifically for professional applications, providing a power socket without constraints, wherever it is required.

Take a wall socket with you - power any device no matter where you are.

With the instagrid system you can power your most demanding devices up to 18.000 W peak.

- 150% overload (5,400 W / 24 A)  
Operation for >500 s possible
- 200% overload (7,200 W / 32 A)  
Operation for >50 s possible
- 250% overload (9,000 W / 40 A)  
Operation for >10 s possible
- Peak Power 18,000 W / 80 A

Power your tools with 3.600 W pure sine from fine electronics to welding. Nothing this powerful has ever come in this size.

Short on time? You can charge the instagrid system even in the middle of your workday within 2,5h.

No grounding required - Instagrid power system is designed according to IEC protection class II

- No tripping hazards - Reduce cabling
- No toxic fumes - Create a healthier work environment, work indoors and in closed spaces.

IP 54+, voltage: 230 V / 50 Hz, rated power: 3.6 kW, max. operating time (idle): 150 h, 16 A, temperature range: -20 to 60 °C

Part no. 579819726

## GENERATORS ENDRESS

Product	Name	Description	Weight (kg)	Measures (mm)	Part no.
	<b>Generator ESE 2100i Silent</b>	DIN 14685-3:2017-05, electrical Power 1,8 kVA, Endress 80i, Power 2,2 kW, sound power level LWA 92 dB(A), nominal voltage 230 V	22	498 x293 x467	579818479
	<b>Generator ESE 3000i</b>	Power: 3,3 kVA, synchronous generator, inverter technology, 1 cylinder, 4 stroke, OHV, Diesel, Electric starter incl. Battery, Connection for 12 V Battery charge, USB connection	41	490 x445 x295	579815544
	<b>Generator Endress ESE 604 DBG DIN</b>	DIN 14685-1. 6,5 kVA. Open frame design. Duplex. Diesel engine Briggs & Stratton Vanguard 16 HP. Electric starter.	105	700 x440 x580	579800302
	<b>Generator Endress ESE 604 DBG ES DIN</b>	DIN 14685-1. 6,5 kVA. Open Frame design. Duplex. Diesel engine Briggs & Stratton Vanguard 16 HP. Electric starter.	105	700 x440 x580	579800303
	<b>Generator Endress ESE 607 DBG DIN Super Silent</b>	DIN 14685-1. 6,5 kVA. Soundproof. Duplex. Diesel engine Briggs & Stratton Vanguard 16 HP. Manual starter.	120	700 x440 x580	579800310
	<b>Generator Endress ESE 607 DBG ES DIN Super Silent</b>	DIN 14685-1. 6,5 kVA. Soundproof. Duplex. Diesel engine Briggs & Stratton Vanguard 16 HP. Electric starter.	135	700 x440 x580	579800311
	<b>Generator Endress ESE 904 DBG DIN</b>	DIN 14685-1. 9,0 kVA. Open Frame design. Duplex. Diesel engine Briggs & Stratton Vanguard 16 HP. Manual starter.	124	820 x440 x580	579800306
	<b>Generator Endress ESE 904 DBG ES DIN</b>	DIN 14685-1. 9,0 kVA. Open Frame design. Duplex. Diesel engine Briggs & Stratton Vanguard 16 HP. Electric starter.	136	820 x440 x580	579800307
	<b>Generator Endress ESE 907 DBG DIN Super Silent</b>	DIN 14685-1. 9,0 kVA. Soundproof. Duplex. Diesel engine Briggs & Stratton Vanguard 16 HP. Manual starter.	130	820 x440 x580	579800313
	<b>Generator Endress ESE 907 DBG ES DIN Super Silent</b>	DIN 14685-1. 9,0 kVA. Soundproof. Duplex. Diesel engine Briggs & Stratton Vanguard 16 HP. Electric starter.	145	820 x440 x580	579800314
	<b>Generator Endress ESE 908 DBG ES DIN Super Silent Plus</b>	DIN 14685-1. 9,0 kVA. Soundproof. Duplex. Diesel engine Briggs & Stratton 16 HP. Electric starter.	132	820 x440 x580	579800318

## GENERATORS ENDRESS

Product	Name	Description	Weight (kg)	Measures (mm)	Part no.
	<b>Generator Endress ESE 954 DBG DIN</b>	DIN 14685-1. 9,0 kVA. Open frame design. Duplex. Diesel engine Briggs & Stratton Vanguard 16 HP. Manual starter.	110	700 x440 x580	579800304
	<b>Generator Endress ESE 954 DBG ES DIN</b>	DIN 14685-1. 9,0 kVA. Open frame design. Duplex. Diesel engine Briggs & Stratton 6 HP. Electric starter.	122	700 x440 x580	579800305
	<b>Generator Endress ESE 957 DBG ES DIN Super Silent</b>	DIN 14685-1. 9,0 kVA. Soundproof. Duplex. Diesel engine Briggs & Stratton Vanguard 16 HP. Electric starter.	127	700 x440 x580	579800312
	<b>Generator Endress ESE 1304 DBG ES DIN</b>	DIN 14685-1. 13,2 kVA. Open frame design. Duplex. Diesel engine Briggs & Stratton Vanguard 23 HP. Electric starter.	148	820 x440 x580	579800309
	<b>Generator Endress ESE 1307 DBG ES DIN Super Silent</b>	DIN 14685-1. 13,2 kVA. Soundproof. Duplex. Diesel engine Briggs & Stratton Vanguard 23 HP. Electric starter.	145	820 x440 x580	579800316
	<b>Generator Endress ESE 1307 DBG ES DIN SS II/ TN-S</b>	According DIN 14685-1, with Switchover device IT-TN, Nominal power three-phase current / alternating current 13,2/7,2 kVA, Nominal power 19,1/31,3 A, Diesel engine B&S, Electric starter.	145	820 x440 x580	579806105
	<b>Generator Endress ESE 1308 DBG ES DIN Super Silent Plus</b>	DIN 14685-1. 13,2 kVA. Super soundproof. Duplex. Diesel engine Briggs & Stratton Vanguard 23 HP. Electric starter.	144	820 x440 x580	579800319
	<b>Generator Endress ESE 1407 DBG ES DIN Super Silent</b>	DIN 14685-1. 13,7 kVA. Soundproof. Duplex. Diesel engine Briggs & Stratton Vanguard 23 HP. Electric starter.	150	820 x440 x580	579800317
	<b>Generator Endress ESE 1408 DBG ES DIN Super Silent Plus</b>	DIN 14685-1. 13,7 kVA. Super soundproof. Duplex. Diesel B&S Motor 23 HP. Electric starter. ECO Tronic.	144	820 x440 x580	579800320









## ACCESSORIES GENERATORS ENDRESS

Product	Name	Description	Weight (kg)	Measures (mm)	Part no.
	<b>Battery charge conservation BEOS, Endress</b>	Outlet for battery charge conservation. Not possible to combine with MagCode or charging outlet DIN 14690	0,6		579800335
	<b>Battery charge conservation MagCode, Endress</b>	Outlet for battery charge conservation. Not possible to combine with BEOS and charging outlet DIN 14690	0,6		579800336
	<b>Battery charge conservation DIN 14690, Endress</b>	Outlet for battery charge conservation DIN 14690 Not suitable for ESE 608. Not possible to combine with MagCode or charging outlet DIN 14690	0,6		579800334
	<b>Fire-Can interface, Endress</b>	Enables remote start and remote monitoring of generator and integrated battery charge conservation	0,25		579800330
	<b>Remote starter device Endress</b>	16-pin connection (Harting connector system) for start-stop commands through central control. Not possible in combination with Fire-Can interface.	0,25		579800329
without image	<b>Automatic choke</b>	for DIN-Generator Endress with Diesel engine	0,25		579800332
	<b>IT-TN incoming supply</b>	Possible for generator ESE 607,807, 1307, 1407. NOTE: no retrofit possible!	0,25		579807545
	<b>ECO Tronic System Endress</b>	For DIN generator Endress	0,25		579800331
	<b>External starter NATO-Outlet, Endress</b>	Not possible for ESE 608	0,25		579800333
	<b>Refuelling system Endress</b>	Incl. Fuelling hose, applicator, and canister.	1,5		579800325
	<b>Hose for fuelling Endress</b>	Incl. Fuelling hose and applicator. Without canister.	0,5		579800326
	<b>Adapter 90° for exhaust pipe, Endress</b>	for exhaust pipe	0,3		579800324
	<b>Set of wheels</b>	Set of wheels for 5 & 8 DIN frames	9,5		579800328

## GENERATORS EISEMANN

Product	Name	Description	Weight (kg)	Measures (mm)	Part no.
	<b>Generator Eisemann BSKA 2,2 RSS</b>	DIN 14685-3:2017-05, Power 1,8 kVa, Nominal power 7,83 A, IP23, 4-Takt Diesel engine, Recoil starter	21,5	500 x280 x450	579818480
	<b>Generator Eisemann BSKA 6,5</b>	DIN 14685-1, open, Power 6,5 kVa, Nominal power 9,3 A, IP54, Diesel engine Briggs & Stratton	118	700 x440 x580	579800820
	<b>Generator Eisemann BSKA 6,5 V</b>	DIN 14685-1, open, Power 6,5 kVa, Nominal power 9,3 A, IP54, Diesel engine Briggs & Stratton	118	700 x440 x580	579800821
	<b>Generator Eisemann BSKA 6,5 E Silent</b>	DIN 14685-1, encapsulated, Power 6,5 kVa, Nominal power 9,3 A, IP54, Diesel engine Briggs & Stratton	118	700 x440 x580	579800822
	<b>Generator Eisemann BSKA 6,5 EV Silent</b>	DIN 14685-1, encapsulated, Power 6,5 kVa, Nominal power 9,3 A, IP54, Diesel engine Briggs & Stratton	118	700 x440 x580	579800823
	<b>Generator Eisemann BSKA 9</b>	DIN 14685-1. Diesel engine B&S 9,0 kVA. Synchronous. Speed 3150 U min-1.	126	700 x440 x580	579800824
	<b>Generator Eisemann BSKA 9 V</b>	DIN 14685-1. Diesel engine B&S 9,0 kVA. Synchronous. Speed controlled. Speed 3150 U min-1.	126	700 x440 x580	579800825
	<b>Generator Eisemann BSKA 9 E</b>	DIN 14685-1. Diesel engine B&S 9,0 kVA. Synchronous. Electric starter. Speed 3150 U min-1.	126	700 x440 x580	579800826
	<b>Generator Eisemann BSKA 9 EV</b>	DIN 14685-1. Diesel engine B&S 9,0 kVA. Synchronous. Electric starter. Speed controlled. Speed 3150 U min-1.	126	700 x440 x580	579800827
	<b>Generator Eisemann BSKA 9 E Silent</b>	DIN 14685-1. Diesel engine B&S 9,0 kVA. Synchronous. Electric starter. Noise reduction.	126	700 x440 x580	579800828
	<b>Generator Eisemann BSKA 9 E RSS Cube</b>	DIN 14685-1, Engine power 10,6 kW, Engine B&S Vanguard E-Start, Sound power level LWA 95 dB(A), 1 CEE three-phase current outlet (16A), 3 shockproof sockets (16A), 12V DC outlet	134		579816323
	<b>Generator Eisemann BSKA 9 E RSS Cube IT/TN</b>	DIN 14685-1, Engine power 10,6 kW, Engine B&S Vanguard E-Start, Sound power level LWA 95 dB(A), 1 CEE three-phase current outlet (16A), 3 shockproof sockets (16A), 12V DC Outlet, IT/TN incoming supply	134		579816882

## GENERATORS EISEMANN

Product	Name	Description	Weight (kg)	Measures (mm)	Part no.
	<b>Generator Eisemann BSKA 13 E</b>	DIN 14685-1. Diesel engine B&S 13,0 kVA. Synchronous. Electric starter. Speed 3150 U min <sup>-1</sup> .	150	820 x440 x580	579800832
	<b>Generator Eisemann BSKA 13 EV</b>	DIN 14685-1. Diesel engine B&S 13,0 kVA. Synchronous. Electric starter. Speed controlled	150	820 x440 x580	579800833
	<b>Generator Eisemann BSKA 14 E Silent</b>	DIN 14685-1, Three-phase current/ Alternating current 13,4/11 kVA, Nominal power 19,3/48 A, IP54, Briggs & Stratton Engine, Electric starter	145	820 x440 x580	579800835
	<b>Generator Eisemann BSKA 14 EV Silent</b>	DIN 14685-1, Three-phase current/ Alternating current 13,4/11 kVA, Nominal power 19,3/48 A, IP54, Briggs & Stratton Engine, Electric starter, Speed controlled	150	820 x440 x580	579805551
	<b>Generator Eisemann BSKA 14 EV RSS cube</b>	DIN 14685-1, Three-phase current/ Alternating current 13,4/5,9 kVA, Nominal power 19,3/48 A, IP54, Sound power level 95 dB(A), Briggs & Stratton Engine, Electric starter, 12-V Outlet	148	820 x440 x580	579806496
	<b>Generator Eisemann BSKA 14 EV RSS cube IT/TN</b>	DIN 14685-1, Three-phase current/ Alternating current 13,4/5,9 kVA, Nominal power 19,3/48 A, IP54,			579816883
	<b>Sound power level 95 dB(A), Briggs &amp; Stratton Engine, Electric starter, 12-V Outlet, IT/TN incoming supply</b>	DIN 14685-1, Motorleistung 14,1 kW, Nennstrom 20,3/48 A, IP54, Schalleistungspegel 94 dB(A), Elektrostart, VarioSpeed	148	820 x440 x580	579808506
	<b>Generator Eisemann BSKA 17 EV RSS cube PMG EFI</b>	DIN 14685-1, Engine power 14,1 kW, Nominal power 20,3/48 A, IP54, Sound power level 94 dB(A), Electric starter, VarioSpeed	148	820 x440 x580	579808507

## ACCESSORIES GENERATORS EISEMANN

Product	Name	Description	Weight (kg)	Measures (mm)	Part no.
	<b>Remote starter device Eisemann</b>	16-pin connection. Not in combination with Fire-Can interface, for DIN generator with Electric starter	0,4		579804002/1
	<b>Remote starter device Eisemann</b>	Outlet for battery charge conservation. Not possible to combine with MagCode or charging outlet DIN 14690	0,2		579804002/2
without image	<b>IT-TN incoming supply</b>	for Generator BSKA 6,5-14 (except Cube) possible. NOTE: no retrofit possible!	1		579808387
	<b>IT-TN incoming supply</b>	for Generator BSKA 14 EV RSS Cube possible. NOTE: no retrofit possible!			579808388
	<b>Charging outlet DIN 14690 Eisemann</b>	for all generators with electric starter (without remote starter device). Fitted at generator and connected to battery.	0,3		579804002/3
	<b>Battery charge conservation MagCode Eisemann</b>	for all generators with electric starter (without Remote starter device). Fitted at generator and connected to battery.	0,3		579804002/4
without image	<b>Fire-Can Interface Eisemann</b>	Enables remote start and remote monitoring of generator and integrated battery charge conservation.	0,2		579804002/5
	<b>Remote starter plug (Nato plug), Eisemann</b>	Plug fits charging socket to enable remote start.	0,3		579800841
	<b>Fuelling kit only B&amp;S GEKO+ Eisemann</b>	Incl. fuelling hose, applicator, and canister.	5,3		579800836
	<b>Fuel withdrawal device</b>	Incl. fuelling hose and applicator. Without canister.	0,64		579800837
without image	<b>Earthing system</b>	Incl. Earthing cable (16 mm <sup>2</sup> - 5 m long) and earthing spike (45 cm long).	1,5		579800842

## CURRENT-CARRYING EQUIPMENT

Product	Name	Description	Weight (kg)	Part no.
	<b>Cable reel KSA 20, 230V, 45 + 5 m</b>	According withdrawn standard 14680 Form A1, Winding width 220mm	20	579800816
	<b>Cable reel KSA 20, 400V 35m</b>	According withdrawn standard 14680 Form A1, Winding width 220mm	20,5	579800817
	<b>Cable reel KSA 42, 400V 50m</b>	According withdrawn standard 14680 Form A2, Winding width 440mm	26	579800818
	<b>Cable reel KSA 20 Ex, 400V 35m</b>	Winding width: 220mm Explosion proof	22,3	579800819
	<b>Solid rubber cable reel Gifas 502 R</b>	DIN 14555-3, Thermal overload protection, H07RN-F 50 m cord 3 x 2,5 mm <sup>2</sup> with shockproof socket IP68, 3 x 230 V shockproof outlet IP68	16	579803602
	<b>Solid rubber cable reel Gifas 503 RG</b>	DIN 14555-3, without Thermal overload protection, H07RN-F 50 m cord 5 x 2,5 mm <sup>2</sup> with CEE plug 400V IP67, 3 x 230 V shockproof outlet IP68, 1x CEE outlet 400V	25	579800234
	<b>Reflective cable reel Dönges Feuerwehr 230V</b>	EN 61316, 50m LiYF11Y-3G2.5 cord with shockproof plug, Outlet: 3 x shockproof coupling, neon yellow, reflective cable	15,8	579816884



## CURRENT-CARRYING EQUIPMENT

Product	Name	Description	Weight (kg)	Part no.
	<b>Reflective cable reel Dönges Feuerwehr 230 V/400 V, 16 A</b>	EN 61316, 50m LiYF11Y-5G2.5 cord with CEE plug, Outlet: 3 x shockproof coupling IP68, 1x CEE, neon yellow, reflective cable	20,5	579816885
	<b>Solid rubber cable reel Dönges 230V, 50 m</b>	EN 61316. Thermal overload protection. Inlet 1x shockproof plug 16A according VG 96926 IP68. Outlet 3x shockproof outlet 16A according VG 96926 IP68.	15,8	579803023
	<b>Solid rubber cable reel Dönges 230V/400V, 50 m</b>	EN61316. VG96926. Thermal overload protection. Inlet 1x CEE plug 16A IP67. Outlet 3x shockproof outlet 16 A IP68, 1x CEE outlet 16A IP67.	20,5	579803024
	<b>Extension cord 10 m, 230 V</b>	Inlet 1x Plug 16 A, IP68. Outlet 1x shockproof cou- pling 16 A, IP68.	2,4	579803025
	<b>Extension cord THW-Version</b>	230V, Inlet 1x shockproof plug IP68. Outlet 1x shockproof coupling IP68. Length 5m	1,3	579806126
	<b>Extension cord THW-Version</b>	230V, Inlet 1x shockproof plug IP68. Outlet 1x shockproof coupling IP68. Length 10m	2,4	579807513

## CURRENT-CARRYING EQUIPMENT

Product	Name	Description	Weight (kg)	Part no.
	<b>Multi-purpose branch piece Delta Box 230 V</b>	DIN VDE 0282. Inlet 1x shockproof plug 16 A IP68. Outlet 3x shockproof socket 16 A IP68.	1,4	579803026
	<b>Multi-purpose branch piece Delta Box 230 V/400 V</b>	DIN VDE 0282. Inlet 1x CEE plug 16A, IP67. Outlet 2x shockproof socket 16A, IP68, hinged 1xCEE socket 16A, IP67, hinged.	1,7	579803027
	<b>Multi-purpose branch piece Delta Box 400 V</b>	DIN VDE 0282. Inlet: 1x CEE plug 16A, IP67. Outlet: 3x CEE socket 16 A, IP67, hinged.	2	579803028
	<b>Triple adapter 230 V</b>	DIN VDE 0282 Inlet: 1x shockproof plug 16A IP68. Outlet: 3x shockproof socket 16A IP68.	0,7	579803029

## CURRENT-CARRYING EQUIPMENT

Product	Name	Description	Weight (kg)	Length	Part no.
	<b>Portable Residual Current Device PRCD, 230 V</b>	According VG 96926. Inlet 1x water pressure-tight shockproof plug 16A, IP68. Outlet 1x water pressure-tight shockproof outlet 16A, IP68.	0,8	2m	579803030
	<b>Portable Residual Current Device PRCD-S, 230 V, THW-Version IP55</b>	VG 96926. 1x water pressure-tight shockproof plug 16 A, IP68. 1x water pressure-tight shockproof outlet 16 A, IP68, Protection class IP55.	0,9	2m	579803031
	<b>Portable Residual Current Device PRCD-S 230 V THW-Version IP68</b>	VG 96926. Inlet 1x water pressure-tight shockproof plug IP68. Outlet 1x water pressure-tight shockproof outlet IP68, Protection class IP68.	0,9	4,5m	579806785
	<b>Portable Residual Current Device PRCD-S 230 V THW-Version IP55</b>	VG 96926. Inlet 1x water pressure-tight shockproof plug IP68. Outlet 1x water pressure-tight shockproof outlet IP68, Protection class IP55.	0,9	4,5m	579807148
	<b>Portable Residual Current Device PRCD-S+</b>	DIN SPEC 14660, Inlet 1x Shockproof plug IP44, Outlet 1x shockproof coupling IP68, Voltage 230 V	0,9	2m	579806684
	<b>Dönges Portable Residual Current Device with Triple adapter, PRCD</b>	IP55, 4,5m H07RN-F3G2.5 according DIN VDE 0282, Outlet 3 x shockproof coupling IP68	0,9	4,5m	579816886
	<b>Dönges Portable Residual Current Device with Triple adapter, PRCD-S</b>	IP68, 4,5m H07RN-F3G2.5 according DIN VDE 0282, Outlet 3 x shockproof coupling IP68	0,9	4,5m	579816887
	<b>Dönges Portable Residual Current Device with Triple adapter, PRCD-S</b>	IP55, 4,5m H07RN-F3G2.5 according DIN VDE 0282, Outlet 3 x shockproof coupling IP68	0,9	4,5m	579816888
	<b>Dönges Portable Residual Current Device with Triple adapter, PRCD-S+</b>	IP55, 4,5m H07RN-F3G2.5 according DIN VDE 0282, Outlet 3 x shockproof coupling IP68	0,9	4,5m	579816890

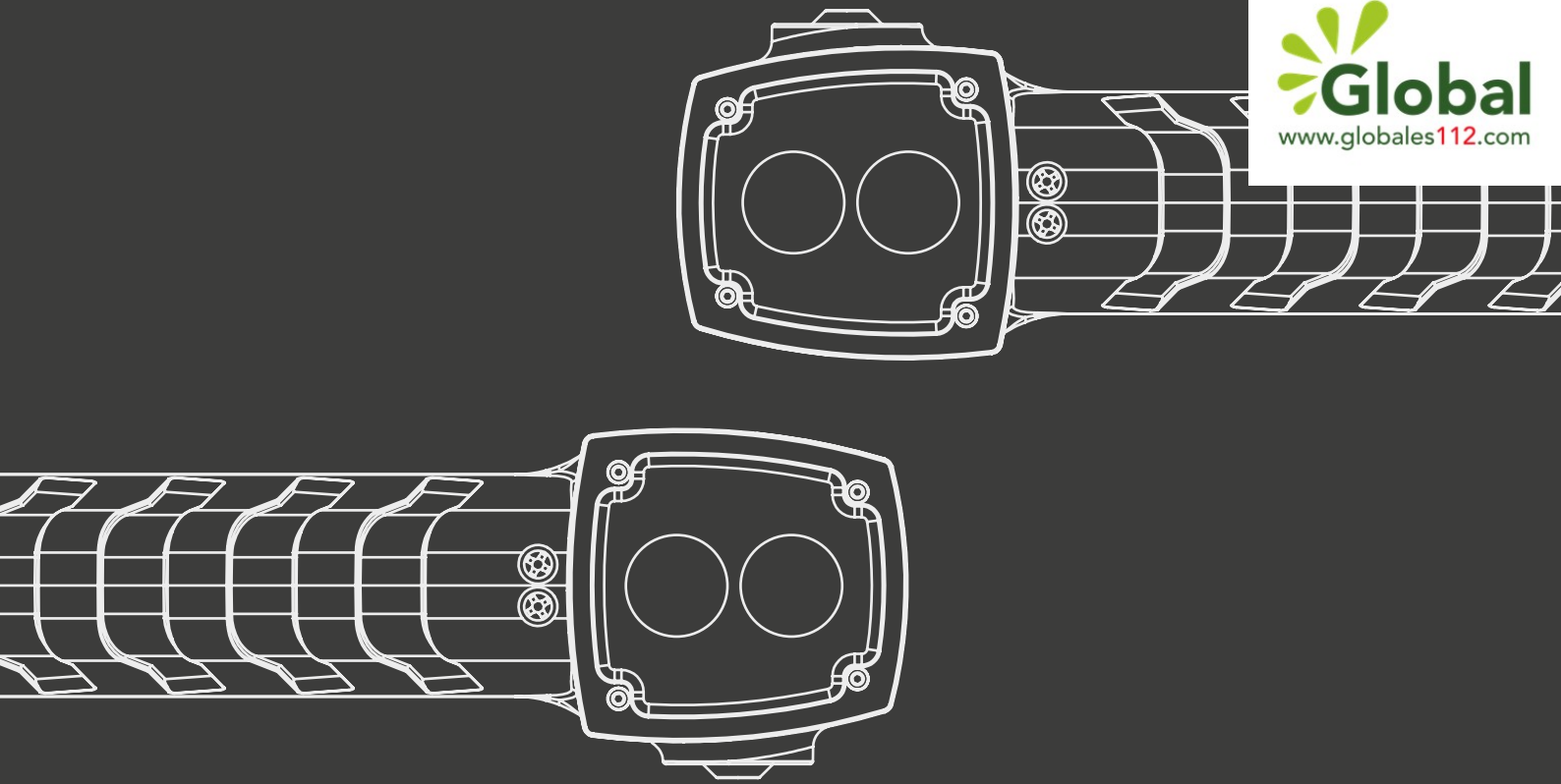

**KSE-LIGHTS**  
**be tough - be safe - be different**



Your specialist for ATEX/iECEx certified explosion-proof lights.  
German quality, local partnerships, secure illumination for challenging environments.



 **KSE-LIGHTS**  
be tough - be safe - be different

# SUPAHERO

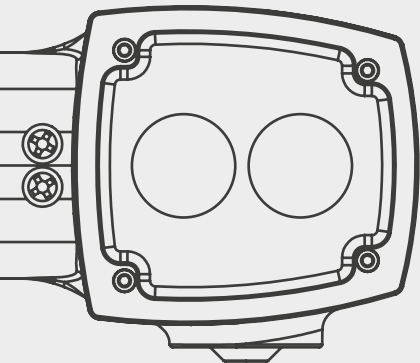

## POWER

Fokus & area lens for maximum brightness and versatility.

## DUALSPOT

Double focus lenses for highest light distance.

## OSIGHT

Special light color for operations in smoke and less glare.



**400 LUMENS**



**ZONE 0**



**380 GRAMS**



**IP68**



**ERGONOMIC**



## SMOKE VISION

The firefighting spotlight enhances vision in smoke, reduces glare, and enables effective action.



## WARRANTY

3-year warranty on the entire light with specially designed stress-tested accumulators. Over 80% capacity retained after 800 cycles.



## INDUCTIVE

Prevents corrosion and significantly increases the lifespan of the light - unique!



## CHEMICAL- & FIREPROOF

Durable, chemically resistant, and fireproof.



## NEWEST STANDARDS

The luminaire is certified according to the latest ATEX standards and complies with the new EN60079-0:2018 and even EN60079-28 for safe optical radiation.



## MADE IN GERMANY

Designed & manufactured in Germany.

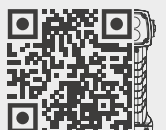

## HAND LAMPS

Product	Name	Description	Weight (kg)	Part no.
	<b>Explosion-proof hand lamp "SupaHERO"</b>	Explosion-proof hand lamp "SupaHERO", with max. 400lm, ATEX / IECEx, DIN 14649 II 1G Ex ia op is IIC T4 II 2D Ex ia op is IIIC 150° Db I M1 Ex ia op is I + H2 Ma -15 °C <Ta< +50 °C	0,4	579819727
	<b>Explosion-proof hand lamp "SupaHERO", double spot type</b>	Explosion-proof hand lamp "SupaHERO", with 400lm, ATEX / IECEx, DIN 14649 II 1G Ex ia op is IIC T4 II 2D Ex ia op is IIIC 150° Db I M1 Ex ia op is I + H2 Ma -15 °C <Ta< +50 °C, double-spot type	0,4	579819728
	<b>Explosion-proof hand lamp "SupaHERO", 0-sight type</b>	Explosion-proof hand lamp "SupaHERO", with 400lm, ATEX / IECEx DIN 14649 II 1G Ex ia op is IIC T4 II 2D Ex ia op is IIIC 150° Db I M1 Ex ia op is I + H2 Ma -15 °C <Ta< +50 °C, 0-sight	0,4	579819729
	<b>Single charging station 230 V for SupaHERO</b>	Inductive charging technology incl. adapter (EU, UK, US, AU)	0,3	579819730
	<b>Single charging station 12-24 V for SupaHERO</b>	Inductive charging technology with car plug 12-24 V	0,2	579819731
	<b>Single charging station 12-24 V for SupaHERO</b>	Inductive charging technology, for installation in cars, DC 12-24 V	0,2	579819732
	<b>Wall mount for charger "SupaHERO"</b>			579819733
	<b>Carabiner snap hook for "SupaHERO"</b>			579819734
	<b>Front clip matt black for "SupaHERO"</b>			579819735
	<b>Exchange battery for "SupaHero"</b>		0,1	579819736

TECHNICAL EQUIPMENT

## HAND LAMPS

Product	Name	Description	Weight (kg)	Part no.
	<b>LED handlamp KS-8890</b>	323 lm, 4x AA-battery (not included), operating time 6 h, with rectangular light head, ATEX 1G-/M1 permission	0,3	579819737
	<b>Wall mount for KS-8890</b>		0,1	579819738
	<b>Front clip matt black for KS-8890</b>			579819739
	<b>Flexible LED strip light "LED-MAMBA"</b>	AC 230 V, 15 m, 1500 lm/m, 6000K	4	579819740
	<b>Flexible LED strip light "LED-MAMBA"</b>	AC 230 V, 25 m, 1500 lm/m, 6000K	6	579819741
	<b>Flexible LED strip light "LED-MAMBA"</b>	AC 230 V, 50 m, 1500 lm/m, 6000K	14	579819742

## HAND LAMPS

Product	Name	Description	Weight (kg)	Part no.
	<b>Flashlight Peli 9050</b>	NFPA 1901, IP 67, 3369 lm, spot, flood, spot/flash and flash modes, flexible battery system		579819746
	<b>Portable spotlight Peli 9415 Z0</b>	IPX4, Certified for ATEX Zone 0 (Kat. 1), 530 Lumen	1,4	579806805
	<b>Flashlight Peli 3765 Z0</b>	IPX4, Certified for ATEX Zone 0 (Kat. 1), 194 Lumen Charger with 230 V Adapter, 4 AA Batteries	0,3	579805892
	<b>Portable spotlight Peli 3715 Z0</b>	IPX4, robust and light 90° lamp, 189 Lumen	0,4	579806558
	<b>Hand lamp Peli 3415MZO</b>	IPX4, certified for ATEX Zone 0 (Kat. 1), 329 Lumen, joint at luminaire head	0,3	579816379
	<b>Hand lamp Peli 3315Z0</b>	IP67, certified for ATEX Zone 0 (Kat. 1), 138 Lumen	0,2	579818100
	<b>Flashlight Peli 1975Z0</b>	ATEX Zone 0, 2 AAA-Batteries, 117 Lumen, thinnest and brightest safety-approved pen light.	0,2	579818103



## HAND LAMPS

Product	Name	Description	Weight (kg)	Part no.
	<b>Vehicle charging cable 12 V with plug Peli</b>	for cigarette lighter socket or on-board socket vehicle charger 8056F	0,1	579805895
	<b>Hand lamp Type ADALIT® L-5000 Z0, Spot Version</b>	ATEX 94/9/EG, Zones 0,1,2,20,21,22, II 1G Ex ia IIC T4 Ga II 1D Ex ia IIIC T135°C Da, Protection class IP66, Light beam to use as searchlight, Luminous range: 530m, Luminous flux 500lm, Luminous period Primary lamp: 6/12/24 h, Luminous period Secondary lamp: 12/24/48 h	1,3	579816892
	<b>Hand lamp Type ADALIT® L-5000 Z0, Flood Version</b>	ATEX 94/9/EG, Zones 0,1,2,20,21,22, II 1G Ex ia IIC T4 Ga II 1D Ex ia IIIC T135°C Da, Protection class IP66, Light beam to light up deployment site, Luminous range: 285m, Luminous flux 500lm, Luminous period Primary lamp: 6/12/24 h, Luminous period Secondary lamp: 12/24/48 h	1,3	579816893
	<b>Hand lamp Type ADALIT® L-5000 Z1, Spot Version</b>	ATEX 94/9/EG, Zones 1,2,21,22, II 2G Ex ia IIC T4 Ga II 2D Ex ia IIIC T135°C Da, Protection class IP66, Light beam to use as searchlight, Luminous range: 530m, Luminous flux 500lm, Luminous period Primary lamp: 6/12/24 h, Luminous period Secondary lamp: 12/24/48 h	1,3	579816894
	<b>Hand lamp Type ADALIT® L-5000 Z1, Flood Version</b>	ATEX 94/9/EG, Zones 1,2,21,22, II 2G Ex ia IIC T4 Ga II 2D Ex ia IIIC T135°C Da, Protection class IP66, Light beam to light up deployment site, Luminous range: 285m, Luminous flux 500lm, Luminous period Primary lamp: 6/12/24 h, Luminous period Secondary lamp: 12/24/48 h	1,3	579816895
	<b>Charger for hand lamp L-5000 12/24 V &amp; 220/240 V</b>	incl. Adapter 230 V, Vehicle charging cable 12/24 V	0,4	579816896
	<b>Charger for hand lamp L-5000 12/24 V</b>	incl. vehicle charging cable 12/24 V	0,4	579816897
	<b>Charger for 2 Hand lamps L-5000 12/24 V &amp; 220/240 V</b>	incl. Adapter 230 V, vehicle charging cable 12/24 V	0,7	579816898
	<b>Charger for 3 Hand lamps L-5000 12/24 V &amp; 220/240 V</b>	incl. Adapter 230 V, vehicle charging cable 12/24 V	1,2	579816899

## HAND LAMPS

Product	Name	Description	Weight (kg)	Part no.
	<b>Hand lamp Adalit L-3000 LED Power</b>	DIN 14649, EX II 1G Ex ia IIC T4 Ga, EX II 1D Ex ia IIC T135°C Da, max. 300 Lumen, Luminous range 250m	0,6	579805071
	<b>Hand lamp Adalit L-3000 LED</b>	DIN 14649, EX II 1G Ex ia IIC T4 Ga, EX II 1D Ex ia IIC T85°C Da, max. 200 Lumen, Luminous range 200m	0,6	579800159
<b>ACCESSORIES ADALIT L2000/3000</b>				
	<b>Charger Adalit 220/240 V, one piece</b>	Charger for 1 Adalit Hand lamp	0,4	579800152
	<b>Charger Adalit 220/240 V, three pieces</b>	Charger for 3 Adalit Hand lamps	1,2	579800154
	<b>Charger Adalit 220/240 V, five pieces</b>	Charger for 5 Adalit Hand lamps	1,9	579800155
	<b>Vehicle charger Adalit 12/24 V, one piece</b>	Charger for one Adalit Hand lamp L-2000 or L-3000.	0,4	579800153
	<b>Vehicle charger Adalit 12/24 V, two pieces</b>	Charger for one Adalit Hand lamp L-2000 or L-3000.	0,7	579806297
	<b>Vehicle charger Adalit 12/24 V, three pieces</b>	Charger for three Adalit Hand lamps L-2000 or L-3000.	1,2	579800157
	<b>Vehicle charger Adalit 12/24 V, five pieces</b>	Charger for five Adalit Hand lamps L-2000 or L-3000.	1,9	579800158
	<b>Holster for Adalit lamp</b>	With reflective stripes.	0,1	579800156



## HAND LAMPS

Product	Name	Description	Weight (kg)	Part no.
	<b>Helmet light ADALIT Penlight L-1, ATEX</b>	94/9/EG,Zones 0,1,2,20,21,22, II 1G Ex ia IIC T4 Ga, EX II 1D Ex ia IIIC T85°C Da, IP67, 2 AAA Micro Batteries 1,5 V, R03, antistatic, Luminous period 18 h, Luminous flux 100 Lumen, Luminous range 57 m	0,06	579816901
	<b>Helmet light ADALIT L-5 Plus</b>	94/9/EG, II 1GD Ex ia IIC T4 Ga, Ex ia IIIC T85°C Da,Zones 0,1,2,20,21,22,IP67, 4 AAA Micro Batteries 1,5 V, R03, Luminous period 30h, Luminous flux 135 Lumen Luminous range 87 m	0,13	579816900
	<b>Helmet light ADALIT L-5R Plus</b>	94/9/EG, II 1GD Ex ia IIC T4 Ga, Ex ia IIIC T85°C Da,Zones 0,1,2,20,21,22,IP67, LiPo Battery/4 AAA Micro Batteries 1,5 V, R03, Luminous period 4-8h, Luminous flux 135 Lumen, Luminous range 87 m	0,13	579804189
	<b>Helmet light ADALIT L-5 POWER</b>	94/9/EG, II 1GD Ex ia IIC T4 Ga, Ex ia IIIC T85°C Da,Zones 0,1,2,20,21,22,IP67, 4 AAA Micro Batteries 1,5 V, R03, Luminous period 30h, Luminous flux 150 Lumen, Luminous range 96 m	0,13	579816902
	<b>Helmet light ADALIT L-5R POWER</b>	94/9/EG, II 1GD Ex ia IIC T4 Ga, Ex ia IIIC T85°C Da,Zones 0,1,2,20,21,22,IP67, LiPo Battery/4 Batteries 1,5 V, Luminous period 4-8h, Luminous flux 150 Lumen, Luminous range 96 m	0,13	579816903
	<b>Charger for one Helmet light ADALIT L-5R</b>	for L-5R Plus ATEX and L-5R Power ATEX. Charge time 4-5 h, Protection class IP 54	0,4	579804190
	<b>Hand lamp Mini MHL 5 EX</b>	Ex-proof Mini Hand lamp with Power LED	0,1	579800174
	<b>Hand lamp HL 10 EX</b>	Explosion proof portable & helmet lamp with Power LED for deployment in Ex-Zones 1, 2, 21 and 22 - incl. 4 x AA Batteries.	0,2	579800175
	<b>Portable spotlight SL 5 LED Set (230/12-24V)</b>	Protection class IP54, Luminous period Primary lamp/ flash mode 5/10h, Luminous flux 170lm, Luminous range ca. 150m, Protection class II	1,1	579804731





## HAND LAMPS

Product	Name	Description	Weight (kg)	Part no.
	<b>Portable spotlight EX SLE 15 LED Set</b>	Safety lamp IP 64 for deployment in gas and dust atmospheres according Ex-Zones 1, 2, 21 and 22.	1,9	579800172
	<b>Portable spotlight EX SLE 15 Set</b>	Regulation 94/9/EG (ATEX), Zones 1, 2, 21, 22, Class II 2 G Ex ib IIC T4, II 2D Ex ibD 21 T 135°C, Protection class IP64.	1,1	579805150
	<b>Portable spotlight EX SLE 16 LED Set</b>	Safety lamp IP 64 for deployment in gas and dust atmospheres according Ex-Zones 1, 2, 21 and 22.	1,9	579800173
	<b>Hand lamp AccuLux HL 35 EX LED, with Battery</b>	DIN 14649. Flexible-head hand lamp IP 67 for deployment in gas and dust atmospheres according Ex-Zones 0,1,2,20,21,22	0,6	579809137
	<b>Hand lamp AccuLux HL 35 EX Set(12-24V) Battery LED charger</b>	DIN 14649. Flexible-head hand lamp IP 67 for deployment in gas and dust atmospheres according Ex-Zones 0,1,2,20,21,22 incl. 12/24V Charger	0,6	579809138
	<b>Hand lamp AccuLux HL 25 EX, LED, with Battery</b>	DIN 14649. Flexible-head hand lamp IP 67 for deployment in gas and dust atmospheres according Ex-Zones 1, 2, 21, 22.	0,6	579800160
	<b>Hand lamp AccuLux HL 25 EX Set(12-24V) Battery LED Charger</b>	DIN 14649. Flexible-head hand lamp IP 67 for deployment in gas and dust atmospheres according Ex-Zones 1, 2, 21, 22, incl. 12/24V Charger	0,9	579800161

## HAND LAMPS

Product	Name	Description	Weight (kg)	Part no.
 	<b>Handleuchte AccuLux HL Hand lamp AccuLux HL 12 LED</b>	Ex-Zones 0/20, Luminous period: ca. 5h, Luminous intensity: ca. 200 Lumen, powered by batteries (Delivery without batteries!)	1,1	579807761
	<b>Hand lamp AccuLux HL 12 LED SET Battery Charger</b>	incl. Charger 12/24V	1,1	579807759
	<b>Hand lamp AccuLux HL 12 LED SET Battery Charger</b>	incl. Charger 230V	1,1	579807760

### ACCESSORIES ACCULUX HL 25 & HL 35

	<b>Charging station one piece</b>	12-24V 100-230V	0,3	579800162 579800167
	<b>Charging station two pieces</b>	12-24V 100-230V	0,6	579800163 579800168
	<b>Charging station three pieces</b>	12-24V 100-230V	1	579800164 579800169
	<b>Charging station four pieces</b>	12-24V 100-230V	1,3	579800165 579800170
	<b>Charging station 12-24V, five pieces</b>	12-24V 100-230V	1,6	579800166 579800171

## HAND LAMPS

Product	Name	Description	Weight (kg)	Part no.
	<b>Hand lamp Combilight KH 22 Ex</b>	DIN 14649:2018-03, IP68, luminous flux max. 400 Lm., illumination range 550 m, 3 light modes, Charge status via 3-color LEDs	0,65	579819759
	<b>Hand lamp Combilight KH 22 Ex Set 1, 230 V</b>	DIN 14649:2018-03, IP68, luminous flux max. 400 Lm., illumination range 550 m, incl. charging station 230 V, adapter insert	0,9	579819753
	<b>Hand lamp Combilight KH 22 Ex Set 2, 230 V</b>	DIN14649,DIN14642,IP68,luminous flux max. 400 Lm.,illumination range 550 m,incl. charging station 230 V,adapter insert,cup handle	1	579819754
	<b>Hand lamp Combilight KH 22 Ex vehicle set 1, 12/24 V</b>	DIN 14649:2018-03, IP68, luminous flux max. 400 Lm., illumination range 550 m, incl. charging station 12/24 V, adapter insert	0,9	579819755
	<b>Hand lamp Combilight KH 22 Ex vehicle-set 2, 12/24 V</b>	"DIN14649,DIN14642,IP68,luminous flux max. 400 Lm.,illumination range 550m,incl. charging station 12/24V,adapter insert,cup handle"	1	579819756
	<b>Hand lamp Combilight KH 22 Ex set 3, 12/24 V (vehicle mounting)</b>	DIN 14649:2018-03, IP68, luminous flux max. 400 Lm., illumination range 550 m, incl. charging station 12/24 V, adapter insert	0,9	579819758
	<b>Hand lamp Combilight KH 22 Ex set 4, 12/24 V (vehicle mounting)</b>	DIN14649,DIN14642,IP68,luminous flux max. 400 Lm.,illumination range 550m,incl. charging station 12/24V,adapter insert,cup handle	1	579819757

## HAND LAMPS





Product	Name	Description	Weight (kg)	Part no.
	<b>Portable spotlight Eisemann HSE 7 LED</b>	LED technology. Lead-acid battery without memory effect. Protection class IP66. Ex-proof EN 50014.	1,5	579800805
	<b>Charging station Eisemann LS for HSE 7 LED</b>	Input voltage 12V-30V DC/230V AC. Charge time 12h. Protection class insulated II.	0,4	579800806
	<b>Adapter Charging station HSE 7 LED</b>	Adapter AR7 LED for Charging station LS230 & LS12/24 HSE 5 HSE7	0,2	579800807
	<b>Hand lamp SURVIVOR Z0 LED/Ex, Battery, Charger</b>	According Regulation 94/9/EG (ATEX), Class II 1G Ex ia IIB T3/T4 Ga, II 2G Ex ia IIC T3/T4 Gb C4-LED, 175 Lumen	0,4	579804821
	<b>Hand lamp SURVIVOR Z0 LED/Ex, Battery</b>	According Regulation 94/9/EG (ATEX), Class II 1G Ex ia IIB T3/T4 Ga, II 2G Ex ia IIC T3/T4 Gb C4-LED, 175 Lumen	0,35	579805975
	<b>Portable spotlight SEB 9 (EX)</b>	Charge time max. 14h Operating time 7h (Primary lamp) Protection class IP 65 Protection class III Light emission Ø 98 mm	1,9	579801289
	<b>Portable spotlight SEB 9 L (EX)</b>	Charge time: max. 8h Operating time: 5h (Primary lamp) Protection class: IP 65 Protection class: III/II Light emission: Ø 98 mm incl. 230V Charger	2,2	579801288

## HAND LAMPS





Product	Name	Description	Weight (kg)	Part no.
	<b>Portable spotlight SEB 10 (EX)</b>	Charge time: max. 8h Operating time: 5.5h (Primary lamp) Protection class: IP 65 Protection class: III Light emission: Ø 98 mm	1,6	579801282
	<b>Portable spotlight SEB 10 L (EX)</b>	Charge time: max. 8h Operating time: 5h (Primary lamp) Protection class: IP 65 Protection class: III/II Light emission: Ø 98 mm incl. 230V Charger	2,1	579801283
	<b>Charger KFZ-Halter 90</b>	Protection class III. Protection class according EN 60529 IP31.	0,7	579801290
	<b>Charger LG 443</b>	Rated voltage: 220 - 250 V AC Protection class: II. Protection class according EN 60529: IP31	1,3	579801291
	<b>Light unit Peli 9430C RALS LED</b>	Luminous flux 3000 lm, Luminous period 8-15 h, 6 LEDs, Length extended 820 mm, 1 Illumination module	1,35	579806134
	<b>Vehicle charger 12-24V for Peli 9430</b>	Vehicle charger 9436, blue plug 10-30V -> 14,7V 2,0A	0,4	579805149



## ILLUMINATORS

Product	Name	Description	Weight (kg)	Part no.
	<b>Working lights Peli 9460C RALS, yellow</b>	Luminous flux 6000 lm per module, Luminous period 3-24 h, 10 LEDs je Modul, Length extended 1800 mm, 2 Illumination modules	27,7	579804879
without image	<b>Vehicle charger 12-24V for Peli 9460</b>		0,1	579816053
	<b>Working lights Peli 9480 RALS, yellow</b>	Luminous flux 4000 lm, Luminous period 6-28 h, 8 LEDs, Length extended 603 mm, 3 Brightness levels (1000/4000 Lumen)	12,5	579816231
	<b>Remote Area Light PELI 9440</b>	Protection class: IP 65, luminous flux max: 5300 lm, 12 LEDs, burn time: 8 h, extended length: 2.1 m, Lilon battery	7,3	579819747
	<b>Remote Area Light PELI 9460M</b>	Protection class: IP 54, luminous flux max: 12000 lm, 20 LEDs, burn time: 3-24 h, extended length: 1,8 m	29	579819347
	<b>Remote Area Light PELI 9470M</b>	Protection class: IP 54, luminous flux max: 12000 lm, 20 LEDs, burn time: 3-24 h, extended length: 1,8 m	49	579818159

## ILLUMINATORS

Product	Name	Description	Weight (kg)	Part no.
	<b>Working lights Peli 9490 RALS, yellow</b>	Luminous flux 6000 lm, Luminous period 4 h, 10 LEDs, Length extended 1829 mm, Intelligent Control	14,5	579806880
	<b>Vehicle charger 12-24V for PELI 9490</b>	12/24V Charging battery with plug for cigarette lighter socket to use in car, truck, or boat.	0,4	579805469
	<b>Setolite deployment site illumination Aldebaran XLD-2</b>	Power 560 W, Luminous flux: 90000 lm, connection cord 8m with shockproof plug IP68, 8 Illumination modules, Shaft sleeve for Push-on attachment pin C DIN 14640, Hook for suspended mounting, dimmable power, delivery incl. transport case.	17,6	579807074
	<b>Setolite deployment site illumination Aldebaran XLD-C Compact Basic</b>	Power 280 W, Luminous flux: 45000 lm, connection cord 8m with shockproof plug IP68, 4 Illumination modules, Shaft sleeve for Push-on attachment pin C DIN 14640, Overhead use possible, delivery incl. transport case, shaft sleeve, 4 viewing panes (Diffusor, connector cable (without dimming & switch function)	8,5	579816904
	<b>Setolite supply line SWITCH for Aldebaran XLD-C Compact</b>	For switching two of the four Aldebaran XLD-C Compact LED modules circuits	0,9	579816905
	<b>Setolite supply line DIM for Aldebaran XLD-C Compact</b>	For switching two of the four Aldebaran XLD-C Compact LED modules circuits	0,9	579816906
	<b>Setolite Aldebaran 360° FLEX LED 600 Compact, Setolite</b>	Protection class IP 54, Power 640W, Light source 4x LED module, Voltage 240V, Luminous flux 90000 lm, Luminous colour 5000 K	15	579805769
	<b>Setolite Aldebaran 360° Flex LED 960, 960W</b>	100-240VAC, 4 LED modules à 240 W. Protection class IP54. LED life cycle 50.000h. Temperature range -30 - +40°C. 10m supply line, plug IP68.	10,5	579803044







## FLOODLIGHTS

Product	Name	Description	Weight (kg)	Part no.
	<b>Transport case for Aldebaran 360°</b>	Practical transport case for the Aldebaran 360°	11	579803045
	<b>Transport case for Setolite Aldebaran Flex 360 Compact600</b>		11	579805770
	<b>Elevador tripod Wind Up 3,75 m, Setolite</b>	Extended height 3,75 m. Height min. 1,73 m. Top load 30 kg	22,6	579805771
	<b>Portable spotlight PLU 2 LED 72W</b>	24 LEDs, Luminous flux 4320lm, Luminous period per battery charge 105 min., IP55	8,7	579805448
	<b>Vehicle charger Type 24/12 for PLU 2 LED 72W</b>	Model 24/12V for 24 Volt vehicles	1,2	579805450
	<b>Setolite floodlights Aldebaran Gladius 2K</b>	10m Connection line with shockproof plug 230V IP68, Luminous flux 23000 lm, Power 160 W, Luminous colour 4000/5700 Kelvin, 2 Illumination modules, DIN inlet for Push-on attachment pin C DIN 14640	6,5	579806123
	<b>Setolite floodlights Aldebaran Gladius 2K</b>	1m connection line with shockproof plug 230V IP68, Luminous flux 23000 lm, Power 160 W, Luminous colour 4000/5700 Kelvin, 2 Illumination modules, DIN inlet for Push-on attachment pin C DIN 14640	6,5	579816907

## FLOODLIGHTS

Product	Name	Description	Weight (kg)	Part no.
	<b>Setolite floodlights Aldebaran Raptor Pro RP1000 LED</b>	5m connection line with shockproof plug 230V IP68, Luminous flux 14500 lm, Power 160 W, with integrated, foldable stand, DIN inlet for Push-on attachment pin C DIN 14640	6,5	579806828
	<b>Setolite floodlights Aldebaran Raptor Pro RP2000 LED</b>	5m connection line with shockproof plug 230V IP68, Luminous flux 23500 lm, Power 150 W, DIN inlet for Push-on attachment pin C DIN 14640	6,5	579815821
	<b>Floodlights BS 500</b>	10 m cable, shockproof plug 16A/250V, light source 230V/1000 W, Handle, Lateral grips, rotating joint and top piece, Protection class IP 55	5	579800179
	<b>Floodlights Meister BS 1000</b>	10 m cable, shockproof plug 16A/250 V, light source 230V/1000W, Handle, Lateral grips, rotating joint and top piece, Protection class IP 55.	5	579800176
	<b>Floodlights Meister LED 90 AC, 10 m</b>	Shockproof plug 16A/250 V, 1 LED-Chip 4000K/9600 Lm, Voltage 100-277V AC, power consumption 92 W, Protection class IP65.	6,7	579800181
	<b>Floodlights LED 90 DC</b>	Charging plug DIN 14690, 1 LED-Chip 4000K/9600 Lm, Connection 12/24V, Power consumption 92 W, Protection class IP65.	6	579804807
	<b>Floodlights Meister LED 180 AC</b>	10m cable, shockproof plug 16A/250 V, 2 LED chips 4000K/23100 Lm, Voltage 100-277V AC, Power consumption 177 W, Protection class IP65	8	579805775
	<b>Floodlights Dönges 60 W LED, 230 V</b>	60 W LED, Protection class IP65, 6500 K, Luminous flux 6000 lm, 230V connection line with water pressure-tight, shockproof plug IP68.	2,2	579807354
	<b>Floodlights Dönges 60 W LED, 230 V</b>	60 W LED, Protection class IP65, 6500 K, Luminous flux 6000 lm, 230V Connection line 10m with water pressure-tight shockproof plug IP68.	2,4	579809489

## FLOODLIGHTS

Product	Name	Description	Weight (kg)	Part no.
	<b>Floodlights Dönges 100 W LED</b>	100 W LED, Protection class IP65, 6500 K, Luminous flux 10000 lm, 230V Connection line 10m with water pressure-tight shockproof plug IP68.	5,4	579808055
	<b>Floodlights Dönges 100 W LED</b>	100 W LED, Protection class IP65, 6500 K, Luminous flux 10000 lm, 230V Connection line 10m with water pressure-tight shockproof plug IP68.	5,6	579808395
	<b>Repair shop hand lamp Dönges, 230 V, 8 W</b>	Lamp length 40 cm. Power 8 W/230 V. Cable length 5 m. Protection class IP23	0,5	579803043
	<b>Support bridge Meister AB 450</b>	Two aluminium pins Ø 30 mm according DIN 14640, Star screw. Pin distance 450 mm.	1,3	579800185
	<b>Support bridge Meister AB 600</b>	With two aluminium pins Ø30mm according DIN 14640 and Star screw. Pin distance 600mm.	1,5	579800186
	<b>Basic support module Meister DUO-LIGHT 450</b>	To mount two floodlights Meister LED 90, LED 130, LED 180, BS 1000, and FS1000.	2,5	579800187
	<b>Basic support module Meister DUO-LIGHT 450 S</b>	with 2 outlets and 10 m cable	4,4	579800188
	<b>Floodlight container - Version 2</b>	10m connection line, fits two floodlights 1000W & LED floodlight	5,4	579806750
	<b>Floodlight container</b>	10 m connection line with water pressure-tight, shockproof plug IP68 and cable reel	6,5	579803017
	<b>Floodlight container set</b>	10 m connection line with water pressure-tight, shockproof plug IP68 and cable reel Incl. 2x Floodlights 60 W LED, IP54	11,5	579808386

## FLOODLIGHTS

Product	Name	Description	Weight (kg)	Part no.
	<b>Dönges Floodlight carrier set</b>	10 m connection line with water pressure-tight, shockproof plug IP68 and cable reel. Incl. 2x floodlights 100 W LED, IP54.	15,4	579808384
	<b>Dönges Floodlight carrier set, incl. Gladius 2K</b>	10 m connection line with water pressure-tight, shockproof plug IP68 and cable reel. Incl. 2x floodlights 160 W LED, IP54.	15,2	579808385
	<b>Tripod 1,8 m</b>	DIN 14683, Max. Capacity 13 kg, Extended height 1,80 m, retracted length 1,15 m.	4,3	579805089
	<b>Telescope tripod 4,75 m</b>	DIN 14682 with air cushioning, Capacity: 25 kg, Extended height 4,75 m, retracted length 1,2 m, incl. lug	13,3	579803019
	<b>Telescope tripod 4,5 m</b>	Cushioned model made from stainless steel, 1x tripod, 1x lug comprising three metal pegs, three straps incl. snap hooks and quick clamps.	13,3	579805088

## WARNING LIGHTS







Product	Name	Description	Part no.
	<b>Flashing light Euro- Blitz Horizont Battery for vehicle charger</b>	Battery 6V/6,5Ah. Operating time: Day 13 h, Night: 11 h. Two-sided, yellow. BAST certified. Without Marking.	579800720
	<b>Flashing light Euro-Blitz for 4 block batteries</b>	4 Batteries 6V/9Ah. Operating time: Day 75h, Night 65 h. two-sided, yellow. Flash frequency ca. 60/min.	579800721
	<b>Flashing light Euro- Blitz Horizont LED Battery for vehicle charger</b>	Lead gel battery 6V/7Ah. Flash energy 1,5 Ws. Flash frequency ca. 60/min. Classification WL 4, two-sided	579800734
	<b>Flashing light Euro- Blitz LED for 4 block batteries</b>	Flash energy 1,5 Ws. Flash frequency ca. 60/min. Classification WL 4, two-sided	579800735
	<b>Flashing light Euro- Blitz Horizont LED Battery for vehicle charger FW</b>	Lead gel battery 6V/7Ah. Flash energy 1,5 Ws. Flash frequency ca.60/min. Classification WL 4, two-sided, Marking Feuerwehr (fire brigade).	579805355
	<b>Flashing light Euro-Synchron with Battery for vehicle charger</b>	Battery, 6V/6,5Ah Operating time: Day: 8h, Night: 7h Version: one-sided	579800723

## WARNING LIGHTS



Product	Name	Description	Part no.
<b>ACCESSORIES EURO-BLITZ</b>			
   	<b>Vehicle charger Horizont for Euro- Synchron and Euro-Blitz</b>	For fixed installation in vehicle, with charging connection for one Euro-Synchron (only 12V) or one Euro-Blitz (12V/24V).	579800732
	<b>Transport/charging box 4 slots for 4 Euro- Blitz/Synchron</b>	To connect with onboard electrical system for Euro-Synchron (12V) or for Euro-Blitz (12/24V). 3m connection line & vehicle Euro plug.	579800726
	<b>Transportation box for 4 Euro-Blitz/Synchron</b>	Transportation box 4 slots Stainless steel model	579800728
	<b>Block battery 6V/9Ah for Flashing lights</b>	Zinc-carbon battery without mercury and cadmium. Long lifetime. Long storage in factory condition	579800729
	<b>Flashing light Euro-Blitz compact LED, Battery, for Vehicle charger</b>	Lead gel battery 6V/4,5 Ah. Without Charger. Two-sided, yellow. Operating time 50 h. BAST certified. With marking „Fire brigade“.	579804894
	<b>Flashing light Euro-Blitz compact LED Battery for vehicle charger</b>	Lead gel battery 6V/4,5 Ah. Without Charger. Two-sided, yellow. Operating time 50 h. BAST certified. For Vehicle charger or adapter.	579804853
	<b>Flashing light Euro-Blitz compact LED, Block-battery</b>	Delivery without block battery, Two-sided yellow, Operating time with 9Ah Battery: 50h, BAST certified	579805072
	<b>Flashing light Euro-Blitz Battery compact Synchron for vehicle charger</b>	Lead gel battery 6V/4,5 Ah, One-sided, Operating time approx. 50h, for Vehicle charger or adapter.	579806409





## WARNING LIGHTS

Product	Name	Description	Part no.
<b>ACCESSORIES EURO-BLITZ COMPACT</b>			
	<b>Vehicle charger Horizontal for Euro-Blitz compact</b>	Connection: 12/24V with Connection line	579804855
	<b>Flashing light Tele-Blitz with Battery for charging adapter</b>	Supply: Battery, 6 V/6,5 Ah Operating time.: Day: 11h, Night: 19h Model: one-sided, yellow	579800737
	<b>Flashing light Tele-Synchron with Battery for Transport/charging box</b>	Supply: Battery, 6 V/6,5 Ah Xenon technology Automatic Synchronisation Incl. Charging adapter Permanent light / Night reduction	579800740
	<b>Flashing light Tele-Synchron for 4 block batteries</b>	Supply: Battery, 6 V/6,5 Ah Xenon-Technology Automatic Synchronisation Incl. Charging adapter Permanent light / Night reduction	579800741
<b>ACCESSORIES TELE-BLITZ/TELE-SYNCHRONOUS</b>			
	<b>Transport/charging box for 2 Tele-Blitz</b>	Transport/charging box suitable for all electrical systems, with individual box for 2 Tele-Blitz / Tele-Synchron	579800742
	<b>Transport/charging box for 4 Tele-Blitz 1</b>	Transport/charging box suitable for all electrical systems, with individual box for 4 Tele-Blitz / Tele-Synchron in parallel	579800743
	<b>Transport/charging box for 4 Tele-Blitz</b>	Transport/charging box suitable for all electrical systems, with individual box for 4 Tele-Blitz / Tele-Synchron consecutively	579800744





## WARNING LIGHTS

Product	Name	Description	Part no.
	<b>Flashing light Horizont Optima-Blitz LED with Toggle switch</b>	Supply: 2 Batteries 6V/9Ah. Operating times 200h. DIN lens, one-sided	579815652
without image	<b>Traffic cone adapter - 37mm</b>	for Optima-Blitz, Euro-Blitz Compact, Euro-Blitz, and Euro- Blitz Synchron to use on top of traffic cones with 37mm mouth	579805548
	<b>Guide light lamp Star-Flash LED 627 A Fire brigade</b>	Flashing light Star-Flash LED Type 627 A, Fire brigade, two-sided, with Battery	579800190
	<b>Guide light lamp Nissen Star-Flash LED 627 B</b>	Flashing light, two-sided, battery operated	579816690
	<b>Guide light lamp for rapid deployment Star-Flash LED 610</b>	Flashing light, two-sided, battery operated	579800200

### ACCESSORIES STAR-FLASH

	<b>Transport/charging tray one piece</b>	12/24 V, with 2 m Connection line and 2-pole vehicle plug.	579800195
	<b>Transport/charging tray 4 slots</b>	Transport/charging tray 12/24 V, 4 slots, with 2m Connection line and 2-pole vehicle plug	579800196
	<b>Mains adapter 110-240 V AC</b>	Mains adapter 110-240 V AC, with Euro main connection and 2-pole vehicle plug for Star-Flash	579800198

## WARNING LIGHTS

Product	Name	Description	Part no.
	<b>Mobile LED sequential hazard set „Synchros“</b>	Consisting of 5 LED guide light elements yellow, Transport/charging box with 1 charging cable with 2-pole vehicle plug	579800225
	<b>Pin lamp Nissen, LED Type 62/S</b>  <b>Pin lamp Nissen, LED Type 62/S</b>	LED flash light, operating time approx.150 h Operating time with 5 Mono cells, two-sided  LED flash light, Operating time approx.150 h Operating time with 5 Mono cells, one-sided	579800202  579806719
	<b>Flashing warning light vehicle, LED</b>	LED light source, Operating time with two 1,5 V Mono cells (D-Cell).	579806317
	<b>Flashing warning light Ulo 3665</b>	Flashing warning light 3665 + A-L + GI-Halogen.	579801041







## TRAFFIC CONES & FOLDING SIGNS

Product	Name	Description	Height	Part no.
	<b>Traffic cone Morion EU</b>	DIN EN 13422, TL cone, BAST certified, Weight class III, Foil type A, made from PE and Recycling-PVC (Foil), fully reflective	500 mm	579805367
	<b>Traffic cone Morion EU</b>	DIN EN 13422, TL cone, BAST certified, Weight class III, Foil type A, made from PE and Recycling-PVC (Foil), fully reflective	750 mm	579805368
 	<b>Traffic cone</b>	retroreflective, Class III, Type B BAST-certified according TL cone. Recyclable base.	500 mm	579806031
	<b>Traffic cone</b>	retroreflective, Kl.III, Type BBAST-certified according TL cone. Recyclable base.	750 mm	579808407
   	<b>Traffic cone, fluorescent</b>	Strong warning effect through fluorescent red with white stripes.	500 mm	579802991
	<b>Traffic cone, fluorescent</b>	Strong warning effect through fluorescent red with white stripes.	750 mm	579802992
	<b>Traffic cone, fully retro-reflective, BAST, Type A</b>	DIN EN 13422. Optimised base. Reflective foil of foil type A, full-surface adhesion. Integrated predetermined breaking point. Stackable.	500 mm	579802993
	<b>Traffic cone, fully retro-reflective, BAST, Type A</b>	DIN EN 13422. Optimised base. Reflective foil of foil type A, full-surface adhesion. Integrated predetermined breaking point. Stackable.	750 mm	579802994







## TRAFFIC CONES & FOLDING SIGNS

Product	Name	Description	Colour	Height	Part no.
	<b>Foldable cone 20M, Pro version</b>	EN 13422. All features of standard foldable cone. Splash-proof flasher. Switch to permanent light.	red/white	500 mm	579802995
	<b>Foldable cone 20MV, Pro version, fully reflective</b>	EN 13422. All features of standard foldable cone. Splash-proof flasher. Switch to permanent light.	red/white	500 mm	579802997
	<b>Foldable cone 20MV, Pro version, fully reflective</b>	EN 13422. All features of standard foldable cone. Splash-proof flasher. Switch to permanent light.	red/white	750 mm	579802998
	<b>Foldable cone 20M, Pro version</b>	EN 13422, with Reflectors, integrated flasher and carrying bag.	red/white	750 mm	579802996

## WARNING & BARRIER MATERIAL

Product	Name	Description	Weight (kg)	Part no.
	<b>Handheld megaphone HM-012 S</b>	with Siren signal, max. 12 W, outdoor reach up to 500m, push-to-talk & volume button, easy to operate by hand	1	579809772
	<b>Handheld megaphone HM-025 S</b>	with Siren signal, max. 24 W, outdoor reach up to 1000m, push-to-talk & volume button, easy to operate by hand	1	579808132
	<b>Handheld megaphone</b>	Reach up to 300 m, inbuild microphone, Addtl. external microphone with 1,5m coiled cable. LED-operated time display.	1,3	579803034
	<b>Battery D Mono cell Duracell LR 20 1,5 V</b>	Quantity: 1 Piece	0,1	579803035
	<b>Warning flag, 500 x 500 mm, white-orange-white</b>	According StVZO. Wooden stick approx. 80 cm long.	0,2	579803068
	<b>Warning flag set for driving in convoy</b>	Consisting of blue, green, red, yellow flag, one per colour	0,9	579803349
	<b>Warning triangle, EN version</b>	Stable EN version ECE-R27 with verification number. Strongly reflective. Delivered in plastic quiver.	0,4	579802983

## WARNING & BARRIER MATERIAL

Product	Name	Description	Weight (kg)	Part no.
	<b>Barrier tape red/ white, neutral, 500 m</b>	Dispenser, 80 mm wide	0,3	579803038
	<b>Barrier tape yellow/ black</b>	Dispenser, 80 mm wide	0,3	579805858
	<b>Barrier tape dispenser</b>	Incl. cutting device	0,3	579815702
	<b>Barrier chain red/ white, 30 m</b>		0,1	579803040
	<b>Mount for barrier tape/ chain</b>	Galvanised spear, 12 mm Ø, with fork for Barrier tape or Barrier chain. 1,2 m	1	579803041
	<b>Foot for mount</b>	Galvanised model with locking screw to keep mount securely fastened up to 12 mm Ø.	0,8	579803042
	<b>Sign stand, complete</b>	Foldable, extendable height: min.: 80 cm, max.: 160 cm.	6	579803069

# POWERFUL, AUTONOMOUS AND COMPACT: THE BATTERY FAN WITH SWAPPABLE LITHIUM BATTERY



Part no. 579809775

## POWERFUL AND AUTONOMOUS

- 50 minutes at 18,600m<sup>3</sup> / h without progressive loss of flowrate. Equipped with a swappable battery, BATFAN 3 Li+ allows operations to be carried out independently. The use of a second battery extends the autonomy to 1h40. Possibility of being connected to the mains for a charge during the intervention.
- NEO technology: Oval jet allows the introduction of maximum air into the building.

## COMPACT AND MOBILE

- Lightweight and equipped with a carrying handle and strap, it is portable by one person. Folds up and stows easily in the trunk of a vehicle. Two BATFAN occupy the space of one conventional fan.

## STABLE AND EASY USE

- The BATFAN 3 Li+ is quicker to set-up than conventional fans. Thanks to its swappable lithium battery, BATFAN 3 Li+ is completely autonomous and can be started instantly without wasting time looking for a power outlet.
- Its design in two articulated parts gives it excellent stability.

## CHARACTERISTICS:



- Air performance: 29.270 m<sup>3</sup>/h
- Air performance according AMCA: 18.600 m<sup>3</sup>/h
- Operating time: 50min at full load
- Inclination: -90° bis +65°
- Engine: Electric engine 600 W
- Connection: Battery or power supply time with shockproof plug IP68 (0,5m)
- Protection class: IP66
- Weight: 24 kg (with Battery)



## VENTILATION EQUIPMENT MAGIRUS

Product	Name	Description	Weight (kg)	Part no.
	<b>Fan MAGIRUS E 220 NEO</b>	Connection 230 V/1500 W, Power 31.200 m <sup>3</sup> /h, 4 Support feet, 86,5 dB(A), Inclination: -10° and +20°	27	579808677
	<b>Fan MAGIRUS E 230 NEO</b>	Connection 230 V/2200 W, Power 40.750 m <sup>3</sup> /h, 2 Transport wheels, 85,3 dB(A), Inclination: -10° and +20°	39,3	579808678
	<b>Fan MAGIRUS EV 230 NEO</b>	Connection 230V/2200 W, Power 40.750 m <sup>3</sup> /h, 2 Transport wheels, 85,3 dB(A), Inclination: -10° and +20°, with speed control	41	579808845
	<b>Fan MAGIRUS M 225 NEO</b>	Connection 2,57 kW, Power 37.700 m <sup>3</sup> /h, 4 Support feet, 94,8 dB(A), Inclination: -10° and +20°	26,8	579808676
	<b>Fan MAGIRUS M 236 NEO</b>	Connection 3,53 kW, Power 51.650 m <sup>3</sup> /h, 2 Transport wheels, 93 dB(A), Inclination: -10° and +20°, incl. exhaust adapter	42	579808680

## VENTILATION EQUIPMENT

Product	Name	Description	Weight (kg)	Part no.
	<b>Water mist nozzle</b>	suitable for Magirus E230, EV230, M236 & Leader MT236/MT240/MT245/MT280, ES(P)(V)230/ES(V)245/ ES(P)(V)280	1,02	579803457
	<b>High expansion foam adapter for fan 16", Storz C</b>	Delivered with 35 m polymeric air pipe, suitable for Magirus M236 & Leader MT215L/MT225 / MT236/MT240, BATFAN/ ES220/ES(V)(P)230, MH236	12	579803454
without image	<b>High expansion foam adapter for Fan 22", Storz C</b>	Delivered with 35 m Polymeric air pipe, MT245/MT280/MT296, ES(V)245/ES(V)(P)280, MH260	12	579803455
	<b>Air pipe</b>	suitable for Magirus E220, E230, EV230 M236 & Leader MT215L/MT225/MT236/MT240, E-FAN 18"/ES220/ES(V)(P)230, MH236	11,5	579806486
		suitable for BATFAN 2 and 3 Li+	12	579815021
		Suitable for MT245/MT280/MT296, ES(V)245/ES(P)(V)280	11,5	579809966
		suitable for ESX230	12,5	579816914
	<b>LEADER V-Box</b>	Cube with built-in structure and 2 quick locks (AG), for Magirus E220, E230, EV230 & Leader ES220/ES(V)(P)230. The V box is fitted with a handle and can be used for transport and protection of fan.	3,5	579805675
	<b>Coiled air pipe for V-Box</b>		11,5	579805676
	<b>Catalyst for Fan LEADER</b>	suitable for Magirus M236 & Leader MT236/MT240/MT245	0,3	579816915
without image	<b>Exhaustion pipe adapter</b>	suitable for MT236/MT240/MT245	0,3	579815921





## VENTILATION EQUIPMENT

Product	Name	Description	Weight (kg)	Part no.
without image	<b>Dust cover fan MAGI- RUS/LEADER</b>		0,2	579805361
	<b>Fan Leader E-Fan 18" with 1 Li-Ion Battery</b>	650 W electric engine with speed control, Air performance according AMCA 18.700 m <sup>3</sup> /h, Operating time 70 Min. at full load, Protection class IP65	23,6	579809139
	<b>Charger 230V for E-Fan 18</b>	Charging time 4 h		579809140
	<b>Li-Ion Battery for E-Fan 18</b>			579809141
	<b>Fan Leader BAT fan 45 V.2</b>	Operating time at full load: 45min., Air performance according AMCA 28.050 m <sup>3</sup> /h, Engine power: 600W, Inclination between -90° and +65°	27,5	579807901
	<b>Fan Leader BATFAN 3 LI+</b>	Operating time at full load: 45min., Air performance according AMCA 28.050 m <sup>3</sup> /h, Engine power: 600W, Inclination between -90° and +65°	24	579809775
	<b>Fan Leader ESX 230</b>	Connection 400V/1850 W, EX-proof, Power 30.000 m <sup>3</sup> /h, 2 Transport wheels, 83,6 dB(A), Inclination: -10° and +20°, with water mist nozzle	65	579803444
	<b>Fan Leader ES 245 EPT</b>	Connection 230V/2200 W, Power 49.050 m <sup>3</sup> /h, 2 Transport wheels, 88,7 dB(A), Inclination: +10° to +20°	53	579803445
	<b>Fan Leader ESV 245 EPT</b>	Connection 230V/2200 W, Power 49.050 m <sup>3</sup> /h, 2 Transport wheels, 88,7 dB(A), Inclination: +10° to +20°, with Speed control	53	579803446
	<b>Fan Leader ESP 230 NEO</b>	Connection 230V/2200 W, Power 40.750 m <sup>3</sup> /h, 2 Transport wheels, 85,3 dB(A), Inclination: -10° and +20°, with Start-up current limiter	75,5	579803442
	<b>Fan Leader ESP 280 EPT</b>	Connection 400V/7500 W, Power 115.700 m <sup>3</sup> /h, 2 Transport wheels, 96,3 dB(A), Inclination: +10° to +20°, with start-up current limiter		579803447
	<b>Fan Leader ESV 280 EPT</b>	Connection 400V/7500 W, Power 115.700 m <sup>3</sup> /h, 2 Transport wheels, 96,3 dB(A), Inclination: +10° to +20°, with speed control	75,5	579803448

## VENTILATION EQUIPMENT

Product	Name	Description	Weight (kg)	Part no.
	<b>Fan Leader MT 215 L NEO</b>	4 stroke Diesel engine 1,54 kW, Power 33.900 m <sup>3</sup> /h, 2 Transport wheels , 94,8 dB(A), Inclination: -10° bis +20°	20,3	579804540
	<b>Fan Leader MT 240 NEO</b>	4 stroke Diesel engine 4,05 kW, Power 68.300 m <sup>3</sup> /h, 2 Transport wheels , 93,0 dB(A), Inclination: +10° bis +20°	41,7	579803435
	<b>Fan Leader MT 245 EPT</b>	4 stroke Diesel engine 4,05 kW, Power 52.320 m <sup>3</sup> /h, 2 Transport wheels , 96,0 dB(A), Inclination: +10° bis +20°	52	579803436





## VENTILATION EQUIPMENT RAMFAN

Product	Name	Description	Weight (kg)	Part no.
	<b>Accu-Fan Ramfan EX50Li-18V</b>	650 W, AMCA 17,200 m <sup>3</sup> /h, compatible with Milwaukee M18 2nd DeWalt FlexVolt batteries, operating time 45 min. at full speed	24,5	579819492
	<b>Accu-Fan Ramfan EX150Li</b>	1400W, AMCA 21.041 m <sup>3</sup> /h, 2x 52V/8Ah Li-Ion batteries with PRO//connect Bluetooth, running time 45 min at full load	24,5	579819493
	<b>Charger 230V for Ramfan EX150Li</b>	230V/3.0A charger for 52V RAMFAN battery, simultaneous. Charging time <3 h	5	579819494
	<b>Charger 12/24V for Ramfan EX150Li</b>	12-24 VDC/3.0A charger for 40V RAMFAN battery, simultaneous. Charging time <3 hrs.	5	579819495
	<b>Li-Ion battery 52V/8Ah for RAMFAN EX150Li</b>	With PRO//connect	2,9	579819496
	<b>High-performance fan RAMFAN EX550</b>	2237W electric motor with speed control	25	579819497
	<b>Fan Ramfan GX350</b>	4,1kW Honda GX200 engine, with air performance according to AMCA 31.799 m <sup>3</sup> /h, operating time 1 hr 50 mins, noise (3 m) 97 dB	38	579819498
	<b>High performance ventilator Ramfan EFi75xx</b>	560 W, air capacity according to AMCA 4250 m <sup>3</sup> /h, safe and reliable device for aggressive environments	2	579819499

## VENTILATION EQUIPMENT RAMFAN

Product	Name	Description	Weight (kg)	Part no.
	Ramfan duct for fans, Ø 30 cm, length 4.60 m, antistatic			579819500
	Ramfan duct for fans, Ø 30 cm, length 7.60 m, antistatic			579819501
	High performance ventilator Ramfan EFi120xx	900 W, air capacity according to AMCA 6375 m <sup>3</sup> /h, safe and reliable device for aggressive environments	28,6	579819502
	High performance ventilator Ramfan UB20xx	Rotor-Ø: 20 cm, noise: 74 dB, voltage: 230V, engine: 0,19 kW, air performance: 1.392 m <sup>3</sup> /Std., protection class: IP55	12	579803173
	High performance ventilator Ramfan UB20xx	With Quick-Couple-container and 4,6m duct		579803175
	High performance ventilator Ramfan UB20xx	With Quick-Couple-container and 7,6m duct		579803174

## SMOKE SHUTTERS

Product	Name	Description	Weight (kg)	Part no.
	<b>Mobile smoke shutter RSS 70 PER</b>	For Door width 70-115 cm. Sealing height up to 195 cm. Up to 600°C	5,8	579809584
	<b>Mobile smoke shutter RSS 70 PER STK</b>	For Door width 70-115 cm. Sealing height up to 195 cm. Carrying bag with slings to fasten to hose carrying basket. Up to 600°C.	6	579809585
	<b>Mobile smoke shutter RSS 80 PER</b>	For Door width 80-140 cm. Up to 600 °C, incl. Carrying bag	6,8	579809586
	<b>Mobile smoke shutter RSS F 80 PER STK</b>	For Door width 80-140 cm. Up to 600 °C, incl. Carrying bag, Carrying bag with slings to fasten to hose carrying basket.		579809587
	<b>Mobile smoke shutter RSS 90 PER</b>	For Door width 90-150 cm. Up to 600 °C, incl. Carrying bag	7,3	579809588
	<b>Mobile smoke shutter RSS F 90 PER STK</b>	For Door width 90-150 cm. Up to 600 °C, incl. Carrying bag, Carrying bag with slings to fasten to hose carrying basket.	5,8	579809589
	<b>Substitute blocker blanket</b>	for RSS F 70-115 / F70 PER for RSS F 80-140 / F80 PER for RSS F 90-150 / F90 PER		579815703 579815704 579815705
	<b>Carrying bag</b>	for RSS 70 PER  for RSS 70 PER STK - with slings to fasten to hose carrying basket  for RSS 80 PER  for RSS 80 PER STK - with slings to fasten to hose carrying basket  for RSS 90 PER  for RSS 90 PER STK - with slings to fasten to hose carrying basket		579816917  579815530  579815820  579816500  579816918  579816919

## HYDRAULIC RESCUE EQUIPMENT LUKAS

Product	Name	Description	Weight (kg)	Part no.
	<b>Motor pump Lukas P 635 SE MDHR20-COAX</b>	DIN EN 13204:2016-12, Electric motor 230V , Power: 2,4kW, Operating pressure 700 bar, Coaxial system	78,5	579807425
	<b>Motor pump Lukas P 635 SG MDHR20-COAX</b>	DIN EN 13204:2016-12, 4 stroke Diesel engine, Power: 2,4kW, Operating pressure 700 bar, Coaxial system	74,3	579808372
	<b>Motor pump Lukas P 635 SE DHR20 230V 50 Hz</b>	DIN EN 13204:2016-12, Electric motor 230V , Power: 2,4kW, Operating pressure 700 bar	76,7	579807893
	<b>Motor pump Lukas P 635 SG DHR20</b>	DIN EN 13204:2016-12 4 stroke Diesel engine with Manual starter , Power: 2,4kW, Operating pressure 700 bar	72,5	579808370
	<b>Motor pump P 635 SE</b>	Simultaneous operation of 2 devices, Electric motor 230 V, Power: 2,4 kW, Connection line 10m with shockproof plug	36,7	579808369
	<b>Motor pump P 635 SG, Diesel engine</b>	Simultaneous operation of 2 devices, 4 stroke Diesel engine, Electric starter, 2,2 kW	32,5	579807392
	<b>Mini electric pump P 605 OE</b>	Enables mobility of hose-bound emergency vehicles. Used with network connector or eWXT high performance battery (Accessory).	23,9	579815035
	<b>Manual pump LH 2/1,8-70MPa with Monocoupling Rettung</b>	Light weight, easy to handle, high mobility, automatic switch from low to high pressure. .	11	579801322









## HYDRAULIC RESCUE EQUIPMENT LUKAS

Product	Name	Description	Weight (kg)	Part no.
	<b>Connecting hose set 5 m</b>	For mounting on motor pump. With bend protection. Incl. turbo marker set.	3	579801384
	<b>Connecting hose set 10 m</b>		5,5	579801385
	<b>Connecting hose set 20 m</b>		10,5	579801386
	<b>Extension hose set 5 m</b>	With bend protection and incl. turbo marker set	3,5	579801387
	<b>Extension hose set 10 m</b>		6	579801388
	<b>Single hose reel SHR 20/1,5</b>	Haspel with mono coupling, Haspel in side version.	18	579801390
	<b>Hydraulic oil LUKAS</b>	for LUKAS Hydraulic pumps, 10 l drum	10	579801321
	<b>Cutting device Lukas Mini S 120</b>	Cutting force max. 183 kN, Round steel bis 22 mm, Opening width 53 mm	4,3	579801338
	<b>Cutting device S 312</b>	Cutting force max. 680 kN, Round steel bis 35 mm, Opening width 160 mm	18,5	579807143
	<b>Cutting device Lukas S 377</b>	Cutting force max. 650 kN, Round steel bis 33 mm, Opening width 206 mm	15,3	579807426
	<b>Cutting device Lukas S 378</b>	Cutting force max. 760 kN, Round steel bis 35 mm, Opening width 202 mm		579809859







## HYDRAULIC RESCUE EQUIPMENT LUKAS

Product	Name	Description	Weight (kg)	Part no.
	<b>Cutting device S 788</b>	Cutting force max. 1101 kN, Round steel bis 42 mm, Opening width 200 mm	18,5	579807233
	<b>Cutting device Lukas S 789</b>	Cutting force max. 1100 kN, Round steel bis 42 mm, Opening width 205 mm		579815030
	<b>Cutting device S 799</b>	Cutting force max. 1376 kN, Round steel bis 45 mm, Opening width 204 mm	18,5	579808074
	<b>Cutting device Lukas S 378 e<sup>3</sup></b>	<p>A convincing overall package of low weight, high cutting forces and superior blade geometry with a large opening width make the S 378 the new standard among compact cutters.</p> <p>A highlight of our e<sup>3</sup> rescue equipment series is the intelligent dashboard, which enables a direct exchange between user and equipment. You get more control during the operation through the different performance indicators on the display. This makes rescue operations smarter, safer, and more efficient.</p> <p>Cutting force up to: 760kN, Round steel up to: 33mm, Knife opening 202mm. NFPA cutting class A7,B8,C7,D8,E8,F4, EN classification I</p> <p>Benefits:</p> <ul style="list-style-type: none"> <li>- POWER UNDER e<sup>3</sup> CONTROL: Smart dashboard with performance diagnostic displays.</li> <li>- Optimized blade geometry with large opening width</li> <li>- Intelligent turbo function for fast and safe work</li> <li>- Wide knife opening to the central bolt</li> <li>- Doubling of working time due to newly developed 9Ah battery pack</li> <li>- Up to 60 minutes working time in 3m deep fresh and salt water</li> <li>- Battery change under water possible</li> </ul>	18,4	579816063
	<b>Cutting device Lukas S 789 e<sup>3</sup></b>	Cutting force max.: 1100kN, Round steel bis: 42mm, Knife opening 205mm	22,4	579816064
	<b>Cutting device Lukas S 799 e<sup>3</sup></b>	Cutting force max.: 1376kN, Round steel bis: 45mm, Knife opening 204mm	24,9	579816065









## HYDRAULIC RESCUE EQUIPMENT LUKAS

Product	Name	Description	Weight (kg)	Part no.
	<b>Cutting device Lukas S 312 eWXT</b>	<p>The new S 312 eWXT offers less weight with identical power values to the E2 predecessor series and a shorter design that significantly improves the balance of the machine. The slim cutting tool offers an outstanding combination of performance and flexibility and, as the eWXT, is one of our liquid-protected rescue tools. It is waterproof, so it can be used in heavy rain, flood or even underwater. The series includes the 5 Ah or 9 Ah rescue battery with the longest operating time in the industry.</p> <p>Cutting force bis: 680kN, Round steel bis: 35mm, Knife opening 160mm. EN classification BC 160 I - 19,3</p> <ul style="list-style-type: none"> <li>- S 312 eWXT is 80 mm shorter and 400 g lighter than the S 312 E2</li> <li>- New brushless motor</li> <li>- Newly developed axial piston pump</li> <li>- Doubling of working time due to newly developed 9Ah battery</li> <li>- Can work for up to 60 minutes in 3m deep fresh water</li> <li>- Battery change under water possible</li> <li>- Constant working speed through electronic speed control</li> </ul>	18,5	579809952
	<b>Cutting device Lukas S 379 eWXT</b>	Cutting force max.: 760kN, Round steel up to: 33mm, Knife opening 202mm	18,4	579815031
	<b>Cutting device Lukas S 788 eWXT</b>	Cutting force max.: 1101kN, Round steel up to: 42mm, Knife opening 200mm	18,5	579809636
	<b>Cutting device Lukas S 789 eWXT</b>	Cutting force max.: 1100kN, Round steel up to: 42mm, Knife opening 205mm	18,5	579809596
	<b>Cutting device Lukas S 799 eWXT</b>	Cutting force max.: 1376kN, Round steel up to: 45mm, Knife opening 204mm	18,5	579809428
	<b>Spreader Lukas SP 333</b>	Spreading force: 42-836 kN, Spreading distance: 600 mm, Squeezing force: 144 kN, Pulling force: 56 kN, Pulling distance: 440 mm	13,5	579807536

## HYDRAULIC RESCUE EQUIPMENT LUKAS

Product	Name	Description	Weight (kg)	Part no.
	<b>Spreader Lukas SP 555</b>	Spreading force: 52-658 kN, Spreading distance: 730 mm, Squeezing force: 115 kN, Pulling force: 58 kN, Pulling distance: 569 mm	16,2	579806112
	<b>Spreader Lukas SP 777</b>	Spreading force: 63-600 kN, Spreading distance: 813 mm, Squeezing force: 122 kN, Pulling force: 60 kN, Pulling distance: 655mm	19,7	579806481
	<b>Spreader Lukas SP 333 e³</b>	Spreading force: 42-836 kN, Spreading distance: 600 mm, Squeezing force: 144 kN, Pulling force: 56 kN, Pulling distance: 440 mm, IP 58	17,1	579816066
	<b>Spreader Lukas SP 555 e³</b>	Spreading force: 52-658 kN, Spreading distance: 730 mm, Squeezing force: 115 kN, Pulling force: 58 kN, Pulling distance: 569 mm, IP 58	19,9	579816067
	<b>Spreader Lukas SP 777 e³</b>	Spreading force: 63-600 kN, Spreading distance: 813 mm, Squeezing force: 122 kN, Pulling force: 60 kN, Pulling distance: 655 mm, IP 58	23,4	579816068
	<b>Spreader Lukas SP 333 eWXT</b>	Spreading force: 42-836 kN, Spreading distance: 600 mm, Squeezing force: 144 kN, Pulling force: 56 kN, Pulling distance: 440 mm, IP 58	20	579815033
	<b>Spreader Lukas SP 555 eWXT</b>	Spreading force: 52-658 kN, Spreading distance: 730 mm, Squeezing force: 115 kN, Pulling force: 58 kN, Pulling distance: 569 mm, IP 58	20	579809429

## HYDRAULIC RESCUE EQUIPMENT LUKAS

Product	Name	Description	Weight (kg)	Part no.
	<b>Spreader Lukas SP 777 eWXT</b>	Spreading force: 63-600 kN, Spreading distance: 813 mm, Squeezing force: 122 kN, Pulling force: 60 kN, Pulling distance: 655 mm, IP 58	20	579815034
	<b>Strong Arm Lukas E 100</b>	230V/50Hz, Spreading force: 28-700 kN, Cutting force: 155kN, with Battery, Charger, door opener tips and combi tips	9,8	579806307
without image	<b>Combi tips</b>	for Lukas Strongarm, Quantity: 1 piece	0,3	579808367
	<b>Combination tool Lukas SC 358</b>	Cutting force max. 492 kN, Opening width 309 mm, Spreading force 38-1500 kN, Spreading distance 368 mm, Pulling force max. 61 kN, Pulling distance 382 mm	14,8	579807434
	<b>Combination tool Lukas SC 758</b>	Cutting force max. 885 kN, Spreading force 43-1500 kN, Spreading distance 475 mm, Pulling force max. 94 kN, Pulling distance 340 mm	14,8	579809168
	<b>Combination tool Lukas SC 258 e³</b>	Cutting force max. 280 kN, Spreading force 32-700 kN, Spreading distance 321 mm, Pulling force max. 34 kN, Pulling distance 330 mm, IP 58	18,4	579816069
	<b>Combination tool Lukas SC 358 e³</b>	Cutting force max. 492 kN, Spreading force 38-1500 kN, Spreading distance 368 mm, Pulling force max. 61 kN, Pulling distance 382 mm, IP 58	18,8	579816070
	<b>Combination tool Lukas SC 758 e³</b>	Cutting force max. 885 kN, Spreading force 43-1500 kN, Spreading distance 475 mm, Pulling force max. 94 kN, Pulling distance 340 mm, IP 58	24	579816071
	<b>Combination tool Lukas SC 258 eWXT</b>	Cutting force max. 280 kN, Spreading force 32-700 kN, Spreading distance 321 mm, Pulling force max. 34 kN, Pulling distance 330 mm, IP 58	14,4	579816924
	<b>Combination tool Lukas SC 358 eWXT</b>	Cutting force max. 492 kN, Spreading force 38-1500 kN, Spreading distance 368 mm, Pulling force max. 61 kN, Pulling distance 382 mm, IP 58		579815039
	<b>Combination tool Lukas SC 758 eWXT</b>	Cutting force max. 885 kN, Spreading force 43-1500 kN, Spreading distance 475 mm, Pulling force max. 94 kN, Pulling distance 340 mm, IP 58		579815040

## HYDRAULIC RESCUE EQUIPMENT LUKAS

Product	Name	Description	Weight (kg)	Part no.
<b>ACCESSORIES CUTTING DEVICES/SPREADER LUKAS</b>				
	<b>Shear blades</b>	for Cutting device S 312 (E2)	2,7	579808379
		for Cutting device S 377 (E2)	2,7	579808380
		for Cutting device S 700 (E2)	4	579808381
		for Cutting device S 799 (E2) (see image)	4	579808382
	<b>Spreader tips „Shark tooth“</b>	for SP 333 E2, SP 333 e³, SP 333 eWXT, SP 555 E2, SP 555 e³, SP 555 eWXT, SP 777 E2, SP 777 e³, SP 777 eWXT	2,5	579806482
	<b>Spreader tip</b>	for Spreader SP 510, with peeling functionality	2,5	579801329
	<b>Spreader tip</b>	for Spreader SP 512, with peeling functionality	2,5	579801330
	<b>Combi tips</b>	for SC 358, SC 358 E2, SC 358 e³, SC 358 eWXT, with 2 combi tips, bolts, screws, and spring thrust pieces	2,5	579816078
without image	<b>Shark Tooth- Combi tips</b>	for SC 758, SC 758 E2, SC 758 e³, SC 758 eWXT	2,5	579816079
	<b>Replacement tips</b>	Door opening tip with 3 Fingers, for Lukas Strongarm	0,3	579808365
	<b>Replacement tips</b>	Door opening tip with 2 Fingers, for Lukas Strongarm	0,3	579808366
	<b>Lukas Adapter set</b>	for SC 757 E2, SC 758, SC 758 E2	24,5	579805187
	<b>Lukas Adapter set</b>	an SC 358, e², eWXT, e³	24,5	579808368
	<b>Pulling device KSV 11</b>	for SP 333/SP 555/SP 777, Length 2x 2,0 m.	13,3	579801332
	<b>Pulling device KSV 8/258</b>	for Combination tool SC 258 E2, SC 258 e³, SC 258 eWXT	13,3	579815036
	<b>Pulling device KSV 13</b>	for Combination tool SC 557/757e²/758e²,e³,eWXT. SC 757e²/758/758e² use in connection with pulling device 579816075	13,3	579801356

## HYDRAULIC RESCUE EQUIPMENT LUKAS

Product	Name	Description	Weight (kg)	Part no.
	<b>Rescue ram R 410</b>	Lifting force 137 kN, Piston stroke 300 mm, Length retracted 450 mm	13	579801361
	<b>Rescue ram R 412</b>	Lifting force 135 kN, Piston stroke 500 mm, Length retracted 680 mm	17,7	579801362
	<b>Rescue ram R 414</b>	Lifting force 124 kN, Piston stroke 700 mm, Length retracted 900 mm	24,2	579801363
	<b>Telescopic ram R 420</b>	Lifting force Piston 1:269 kN, Piston 2:134 kN, Total lift 575 mm, Length retracted 480 mm, Length extended 1055 mm	16,8	579801364
	<b>Telescopic ram R 422</b>	Lifting force Piston 1:269 kN, Piston 2:134 kN, Total lift 705 mm, Length retracted 550 mm, Length extended 1255 mm	18,8	579801365
	<b>Telescopic ram R 424</b>	Lifting force Piston 1:269 kN, Piston 2:134 kN, Total lift 875 mm, Length retracted 625 mm, Length extended 1500 mm	20,9	579801366
	<b>Telescopic ram R 430</b>	Lifting force Piston 1:269 kN, Piston 2:134 kN, Piston 3: 39 kN, Piston stroke 1:295 mm, Piston stroke 2:280 mm, Piston stroke 3: 245mm, Length retracted 475 mm, Length extended 1295 mm	17,7	579801367
	<b>Telescopic standard ram R 520 e<sup>3</sup></b>	Extended/retracted Length: 1126/624 mm, Stroke: 624 mm, Lifting force Piston 1/2: 127/60 kN, Piston stroke Piston 1/2: 325/299 mm, IP58	17,2	579816072
	<b>Telescopic standard ram R 521 e<sup>3</sup></b>	Extended/retracted Length: 1359/780 mm, Lifting force Piston 1/2: 127/60 kN, Piston stroke Piston 1/2: 325/299 mm, IP58	17,2	579816073
	<b>Telescopic standard ram R 522 e<sup>3</sup></b>	Extended/retracted Length: 1503/876 mm, Stroke: 876 mm, Lifting force Piston 1/2: 127/60 kN, Piston stroke Piston 1/2: 325/299 mm, IP58	20,3	579816074

## HYDRAULIC RESCUE EQUIPMENT LUKAS

Product	Name	Description	Weight (kg)	Part no.
	<b>Telescopic standard ram R 520 eWXT</b>	Extended/retracted Length: 1126/624 mm, Stroke: 624 mm, Lifting force Piston 1/2: 127/60 kN, Piston stroke Piston 1/2: 325/299 mm, IP58	17,2	579815037
	<b>Telescopic standard ram R 521 eWXT</b>	Extended/retracted Length: 1359/780 mm, Stroke: 780 mm, Lifting force Piston 1/2: 127/60 kN, Piston stroke Piston 1/2: 325/299 mm, IP58	20,8	579809431
	<b>Telescopic standard ram R 522 eWXT</b>	Extended/retracted Length: 1503/876 mm, Stroke: 876 mm, Lifting force Piston 1/2: 127/60 kN, Piston stroke Piston 1/2: 325/299 mm, IP58	17,2	579815038
	<b>Battery Li-Ion 5 Ah</b> <b>Battery Li-Ion 3,9 Ah</b>	for emergency devices in eDraulic series for Lukas Strongarm	0,9	579801317 579808360
	<b>Battery Li-Ion 5 Ah</b>	for emergency devices in eWXT and e <sup>3</sup> series	0,9	579809432
	<b>Battery Li-Ion 9 Ah</b>	for emergency devices in eWXT and e <sup>3</sup> series	0,9	579809433
	<b>Charger 12-24 V DC eDRAULIC</b> <b>Charger 12/24 V DC</b>	for Lukas Battery 2,6 + 5 Ah for Lukas Strongarm Battery 3,9 Ah	0,6 0,2	579801319 579808361
	<b>Charger 230 V DC eDRAULIC</b> <b>Charger 230 V</b>	for Lukas Strongarm	0,6 0,2	579801318 579808362
	<b>Adapter 230 V DC 2.0 eDRAULIC</b>	Enables work through continuous power supply	3,1	579801320



## HYDRAULIC RESCUE EQUIPMENT LUKAS

Product	Name	Description	Weight (kg)	Part no.
	<b>Charger 230 V DC</b>	for emergency devices in eWXT and e <sup>3</sup> series	0,6	579809434
	<b>Charger 12-24 V AC</b>	for emergency devices in eWXT and e <sup>3</sup> series	0,6	579809435
	<b>Adapter 230 V DC</b>	for emergency devices in eWXT and e <sup>3</sup> series Enables work through continuous power supply	3,1	579809595
	<b>Extension Lukas</b>	Extension 250mm for Lukas standard ram LZR 12-300/R 410	1,9	579801368
	<b>LUKAS LX CLAW, Set</b>	<p>Designed to support „CrossRamming“. By increasing the surface area, it ensures that any type of material can be pushed away using the rescue cylinder and prevents the cylinder claw from piercing through the material.</p> <p>Quantity: 1x LX CLAW S (WxHxD) 347x95x301 mm 1x LX CLAW L (WxHxD) 434x95x376 mm</p>	14,9	579816257
	<b>Support bearing Lukas LX RAM C</b>	Stable and non-slip support bearing that can be adapted to the respective vehicle type.	12,1	579801381
	<b>Support bearing Lukas LX RAM T</b>	Provides safe and stable support in both vertical and horizontal positions. It contains three fully loadable abutments for three different support widths.	7,7	579807526
	<b>Support system LSS Set I</b>	Blocks, Wedges, and other support elements.	12,5	579801395
	<b>Support system Lukas LSS Set II</b>	Blocks, Wedges, and other support elements	25	579801396

## HYDRAULIC RESCUE EQUIPMENT LUKAS

Product	Name	Description	Weight (kg)	Part no.
	<b>Support system Lukas LSS step chock</b>	To support and stabilise.	8,2	579801397
	<b>Support system LSS support block</b>	To support and stabilise.	6,7	579801398
	<b>Stabilization system Lukas LX Strut 2.0</b>	Length: 1070mm retracted, 1850mm extended, 4000mm Webbing, configurable in 32 steps, Load on the support in longitudinal direction 2100 kg	5,1	579809824
	<b>LX Strut carrying bag</b>	Offers space for up to 3 LX Strut systems	0,3	579809825
	<b>Lifting set H1</b>	Lifting sets to lift and stabilise heavy or moving loads.	53,4	579801403
	<b>Lifting set H2</b>		35,5	579801404
	<b>Tarpaulin Lukas LX-BASE</b>	This multifunctional tarpaulin is made of tear-resistant, waterproof, and dirt-repellent fabric.	3,4	579816258





## HYDRAULIC RESCUE EQUIPMENT LUKAS

Product	Name	Description	Weight (kg)	Part no.
	<b>Air Bag Safe Set 1 - Driver side</b>	against late deploying airbags	1,5	579801399
	<b>Air Bag Safe Set II - Co-driver side</b>	against late deploying airbags	2,8	579801400
	<b>Air bag safety system (A.S.S.) set, driver side, truck</b>	For Steering wheel diameter 43-50 cm.	1,3	579803121
	<b>Air bag safety system (A.S.S.) set, Driver side passenger car/van</b>	For Steering wheel diameter 35-39 cm and 40-45 cm.	1,7	579803120
	<b>Air bag safety system (A.S.S.) Complete set driver side Dönges</b>	For Steering wheel diameter 35-39 cm, 40-45 cm and 43-50 cm.	2,2	579803119
	<b>Air bag safety system (A.S.S.) Set Co-driver side passenger car, Dönges</b>	5 lashing straps help to connect the system quickly, with severed roof or intact vehicle.	4,2	579803122

## HYDRAULIC RESCUE EQUIPMENT LUKAS

Product	Name	Description	Weight (kg)	Part no.
	<b>Glass management Lukas LX GLASS</b>	To create supply or rescue opening and protection of wounded individuals.	4	579816264
	<b>Set protective covers III, Lukas</b>	To protect the rescue team from injuries at sharp points	7	579801394
	<b>Set protective covers Lukas LX COVER S</b>	Quantity: 1x large Protective cover, 1x small Protective cover, 2x protective bags for vehicle pillars, 1x Carrying bag	3,7	579816260
	<b>Set protective covers Lukas LX COVER L</b>	Quantity: 1x large Protective cover, 2x small Protective cover, 4x protective bags for vehicle pillars, 1x Carrying bag	4	579816261
	<b>Splinter guard LX- GUARD</b>	Reliably keeps glass splinters away from the accident victim and is therefore indispensable for a patient-friendly rescue.	1,5	579801402
	<b>Set protective covers Economy, Set A</b>	5 pieces for one vehicle half	3,4	579804562
	<b>Lukas Glass saw LX CUT</b>	Convinces through handiness, robust design and outstanding cutting performance when cutting laminated safety glass.	0,65	579816265

## HYDRAULIC RESCUE EQUIPMENT LUKAS

Product	Name	Description	Weight (kg)	Part no.
	<b>Spring centre punch</b>	To shatter windows made of safety glass.	0,15	579801335
	<b>Spring centre punch - Special</b>	Effective accessory to shatter front and side windows of cars and trucks.	0,6	579803114
	<b>Combination set HTS99/ LCS 99</b>	One door opener and one mini blade set together in one transport case.	25	579809254
	<b>Small cutter LUKAS LCS 99</b>	For cutting pedals, steering wheels, or bars in confined spaces. Cutting force up to 75kN, Knife opening 40mm	8,8	579809253
	<b>Hydraulic door opener LUKAS HTS 99</b>	Opens multi-locked metal doors or security doors in case of fire, accidents, or police operations in buildings. Spreading force up to 90 kN, Stroke 100 mm	8,8	579809255

# POWER UNDER CONTROL

## Ready for the next level of rescue operations?

With the new LUKAS e3-series you will work more efficiently and safely from now on – thanks to a smart dashboard for better control.

**Smart. Safe. Efficient.**

# DISCOVER THE NEXT DIMENSION

## Get connected to the future of saving lives.

LUKAS e<sup>3</sup> CONNECT features smart sensors and IoT-exchange with the Captium™ service platform. For a full overview of all devices – and more operational readiness than ever before.

**Any. Time. Ready.**



# LUKAS

LUKAS Hydraulik GmbH A Unit of IDEX Corporation

Weinstraße 39 · 91058 Erlangen · Germany · +49 9131 698-0 · [lukas.info@idexcorp.com](mailto:lukas.info@idexcorp.com) · [www.lukas.com](http://www.lukas.com)

## HYDRAULIC RESCUE SYSTEMS WEBER

Product	Name	Description	Weight (kg)	Part no.
	<b>Electrical power unit Weber E 70 W-SAH 20</b>	EN-Class ATO/MTO. Nominal pressure 700 bar. Usable volume 6,5 l. Incl. Equipment mount	80	579804779
	<b>Electrical power unit Weber E 70 W-SAH 20 COAX</b>	EN-Class ATO/MTO. Electric motor 230V. Nominal pressure 700 bar. Usable volume 6,5 l. Incl. Equipment mount		579804782
	<b>Electrical power unit Weber V 70 W-SAH 20</b>	EN-Class ATO/MTO. Nominal pressure 700 bar. 4-Stroke-Diesel engine. Power 4kW, Usable volume 6,5 l. Incl. Equipment mount	80	579804780
	<b>Electrical power unit Weber V 70 W-SAH 20 COAX</b>			579804781
	<b>Battery-Aggregate B- COMPACT ECO</b>	DIN EN 13204:2016-12, Nominal pressure 700 bar, Usable volume 2,8 l	12,2	579805761
	<b>Electrical power unit V 400 S</b>	EN-Class STO Nominal pressure 700 bar, Usable volume 2,5 l	17,3	579802103
	<b>Electrical power unit V 400 ECO</b>	EN-Class STO Nominal pressure 700 bar Usable volume 2,5 l	17,3	579802104
	<b>Electrical power unit V-ECOCOMPACT</b>	EN-Class ATO/MTO Nominal pressure 700 bar Usable volume 3,8 l	23,9	579802105
	<b>Electrical power unit E-COMPACT</b>	EN-Class STO. Nominal pressure 700 bar. Usable volume 2,8 l.	12,5	579802099

## HYDRAULIC RESCUE SYSTEMS WEBER

Product	Name	Description	Weight (kg)	Part no.
 	<b>COAX Extension hose 10 m</b>	with SINGLE couplings	5,5	579805219 yellow 579805220 red
	<b>COAX Extension hose 20 m</b>		10	579802273 yellow 579802274 red
 	<b>Extension hose pair 20 m</b>	with SINGLE couplings	13	579802269 yellow 579802270 red
	<b>Cutting device Weber S 50</b>	Class AC-50-B-4,2, EN cutting class 1C-2D-3B, ideal in confined spaces, Opening width 50 mm	4,3	579808892
	<b>Cutting device Weber RSC 170</b>	DIN class BC166I-14,3, EN cutting class 1J-2K-3I-4J-5J, NFPA cutting class A7-B8-C6-D8-E9-F4, opening width 175 mm	14,3	579819858
	<b>Cutting device Weber RSC 190</b>	DIN class BC187K-16,9, EN cutting class 1K-2K-3K-4K-5K, NFPA cutting class A8-B9-C7-D9-E9-F4, opening width 185 mm	16,9	579819857
	<b>Cutting device Weber RSC 200</b>	DIN class CC201K-20,9, EN cutting class 1K-2K-3K-4K-5K, NFPA cutting class A9-B9-C9-D9-E9-F5, opening width 200 mm	20,9	579819859
	<b>Cutting device Weber RSC 170 E-Force 3</b>	DIN class BC166I-18,1, EN cutting class 1J-2K-3I-4J-5J, NFPA cutting class A7-B8-C6-D8-E9-F4, opening width 175 mm	18,1	579819861
	<b>Cutting device Weber RSC 190 E-Force 3</b>	DIN class BC187K-20,6, EN cutting class 1K-2K-3K-4K-5K, NFPA cutting class A8-B9-C7-D9-E9-F4, opening width 185 mm	20,6	579819862



## HYDRAULIC RESCUE SYSTEMS WEBER

Product	Name	Description	Weight (kg)	Part no.
	<b>Cutting device Weber RSC 200 E-Force 3</b>	DIN class CC201K-24,8, EN cutting class 1K-2K-3K-4K-5K, NFPA cutting class A9-B9-C9-D9-E9-F5, opening width 200 mm	24,8	579819860
	<b>Spreader SP 44 AS</b>	EN Class AS 44/610-13,3 Spreading force (in the working area) 44-857 kN Spreading distance* 610 mm Squeezing force 149 kN	13,3	579807805
	<b>Spreader SP 50 BS</b>	EN Class BS 50/805-17,1, Spreading force (in the working area) 50-501 kN, Spreading distance 805 mm, Squeezing force 144 kN	17,1	579809177
	<b>Spreader SP 54 AS</b>	EN Class AS 55/735-16,9, Spreading force (in the working area) 55-501 kN, Spreading distance 735 mm, Squeezing force 144 kN	16,9	579809244
	<b>Spreader SP 64 BS</b>	EN Class BS 64/820-20,1, Spreading force (in the working area) 64-680 kN, Spreading distance 820 mm, Squeezing force 129 kN	20,1	579809245
	<b>Spreader SP 84 CS</b>	EN Class CS 82/660-19,8, Spreading force (in the working area) 82-680 kN, Spreading distance 660 mm, Squeezing force 129 kN	19,8	579809246
	<b>Spreader SP 44 AS E-Force 3</b>	EN Class AS 44/610-17,2. Spreading force (in the working area) 44-857 kN. Spreading distance 610 mm. Squeezing force 149 kN. - without Battery	13,3	579808502
	<b>Spreader SP 50 BS E-Force 3</b>	EN Class BS 50/805-17,1, Spreading force (in the working area) 50-501 kN, Spreading distance 805 mm, Squeezing force 144 kN	20,9	579809483
	<b>Spreader SP 54 AS E-Force 3</b>	EN Class AS55/735-20,7, Spreading force (in the working area) 55-501 kN, Spreading distance 735 mm, Squeezing force 144 kN	20,7	579816948

## HYDRAULIC RESCUE SYSTEMS WEBER

Product	Name	Description	Weight (kg)	Part no.
<b>ACCESSORIES SPREADER WEBER</b>				
without image	<b>Spreader tips Universal for SP 44</b>		0,9	579809164
	<b>Spreader tips Universal for SP 54 AS/ 50 BS</b>		1	579809247
	<b>Spreader tips Universal for SP 64 BS / SP 84 CS</b>		1,5	579809251
	<b>Pulling device 1,8 m long</b>	for Weber SP35 AS, SP53 BS, SP54 AS, SP50 BS, 2 shackles, 2 Drag chains, with Hook.	13,8	579802140
	<b>Pulling device 1,8 m long</b>	for SP 40 C / SP 44 AS	13,8	579802217
	<b>Pulling device 1,8 m long</b>	for SP 64 BS / SP 84 CS	13,8	579809249
	<b>Combination tool SPS 370 E-FORCE 3</b>	Protection class IP 54, CK37/370-H-19,9, 11-2J-3H-4J-5I, Opening width 370 mm, Spreading force (in the working area) 44–783 kN, Pulling distance 390 mm, max. Squeezing force 52 kN, Cutting power at Round steel 30 mm	19,9	579807412
	<b>Combination tool Weber RIT-TOOL E-FORCE 3</b>	EN Class AC140H-13,3 NFPA Cutting class A6/B7/ C6/D7/E7/F3, Opening width: 215mm, EN-Cutting class: 1H-2H-3H-4H-5H, Spreading force: 30-1305 kN, Spreading distance: 241 mm, Pulling force: 47 kN, Pulling distance: 320 mm	13,3	579815434
	<b>Combination tool Weber SPS 400 MK2 E-FORCE 3</b>	EN-Class CK35/405I-21,0 NFPA-Schneid- class A7/ B9/C7/D9/E9/F6, Opening width: 343mm, EN-Cutting class: 1I-2K-3J-4K-5J, Spreading force: 35-1071 kN, Spreading distance: 405 mm, Pulling force: 58 kN, Pulling distance: 450 mm	21	579816450
	<b>Handvario Weber RIT-Tool</b>	EN-Class K25-G-M NFPA-Cutting class A6/ B7/ C6/D7/E7/F3, Opening width: 215mm, EN-Cutting class: 1H-2G-3G-4H-5G, Spreading force: 25-1175 kN, Spreading distance: 280 mm, Pulling force: 40 kN, Pulling distance: 320 mm	11,1	579816629

## HYDRAULIC RESCUE SYSTEMS WEBER

Product	Name	Description	Weight (kg)	Part no.
<b>ACCESSORIES COMBINATION TOOL WEBER</b>				
without image	<b>Spreader tips</b>	Spreader tips RIT-TOOL / HANDVARIO RIT-TOOL SPS 370 MK2 / SPS 400 MK2	0,8	579802176
	<b>Door opener tips Weber</b>	for RIT-TOOL / HANDVARIO RIT-TOOL SPS 370 MK2 / SPS 400 MK2	13,3	579815436
	<b>Long special tip (1 Piece)</b>	for RIT-TOOL / HANDVARIO RIT-TOOL SPS 370 MK2 / SPS 400 MK2	0,8	579816530
	<b>Pulling device</b>	for RIT-TOOL / HANDVARIO RIT-TOOL SPS 370 MK2 / SPS 400 MK2, two pieces are required to use device	1,4	579802183
	<b>Rescue ram Weber RZ 1-850</b>	Compression force 137 kN, Piston stroke 320 mm, Length 530 mm, Pulling force 26 kN	11,7	579802187
	<b>Rescue ram Weber RZ 2-1290</b>	Compression force 137 kN, Piston stroke 540 mm, Length 750 mm, Pulling force 26 kN	16,4	579802188
	<b>Rescue ram Weber RZ 3-1640</b>	Compression force 137 kN, Piston stroke 540 mm, Length 1100 mm, Pulling force 26 kN	19,4	579802189
	<b>Telescopic Standard ram Weber RZT 2-775</b>	Compression force 1/2 189,4/99 kN, Piston stroke 380 mm, Length 395 mm, Two stages	11,5	579802191
	<b>Telescopic Standard ram Weber RZT 2-1500</b>	Compression force 1/2 189,4/99 kN, Piston stroke 850 mm, Length 650 mm, Two stages	18	579802193
	<b>Telescopic Standard ram RZT 2-1500 XL</b>	Compression force 1/2 269,4/129,5 kN, Piston stroke 852 mm, Length 650 mm, Two stages	20,9	579802197

## HYDRAULIC RESCUE SYSTEMS WEBER

Product	Name	Description	Weight (kg)	Part no.
	<b>Standard ram Weber RZ 1-910 E-FORCE 2</b>	Length 540 mm, Piston stroke 368 mm, Compression force 111,3 kN	14,7	579805133
	<b>Standard ram Weber RZT 2-1360 E-FORCE 2</b>	Length 586 mm, Piston stroke 800 mm, Compression force 1./2. level 108/62 kN	19,8	579805988
	<b>Telescopic Standard ram Weber RZT 2-1500 E-FORCE 2</b>	Compression force 108/62 kN, Initial length 700mm, Piston stroke 800mm, Final length 1500mm	21	579808160

### ACCESSORIES STANDARD RAM WEBER

	<b>Extension Standard ram</b>	for Weber RZT 2-600, RZT 2-775	3,4	579802222
	<b>Extension for Standard ram 175 mm</b>	for RZ 1-850 and RZ 1-910	2	579802223
	<b>Extension for Standard ram 250mm</b>	for RZ 1-850 and RZ 1-910	2,5	579802224
	<b>Extension for Standard ram 320 mm</b>	for RZ 1-850 and RZ 1-910	3	579802225
	<b>Battery 28 V/5 Ah</b>		1	579802233
	<b>On-board charger</b>		1	579802236







## HYDRAULIC RESCUE SYSTEMS WEBER

Product	Name	Description	Weight (kg)	Part no.
	<b>Network charger 230 V for 1 Battery</b>  <b>Network charger 110 V for 1 Battery</b>		0,8	579802234  579802235
	<b>Permanent power supply, Adapter 230 V</b>  <b>Permanent power supply, Adapter 110 V</b>		3,3  5	579802237  579802238
	<b>Jacking device Weber Buffalo B 10</b>	Maximum force 10.000 kg, without bearing plate	38,5	579802124
without image	<b>Bearing plate flat, quadratic for Weber jacking device Buffalo B 10</b>		1,8	579802126
	<b>Foot round v for B 10</b>		1,8	579802128
	<b>Bearing plate B 5 / B 10</b>		1,8	579802129
	<b>Substructure system Weber STAB-PACK</b>		8,6	579802252
	<b>Substructure system Weber STAB-PACK Set</b>	4 STAB-PACK in Eurobox.	38	579802253
	<b>Substructure system Weber STAB- LOCK Set</b>	In Eurobox.	29	579802254

## HYDRAULIC RESCUE SYSTEMS WEBER

Product	Name	Description	Weight (kg)	Part no.
	<b>Subsystem Push block Weber</b>	For stabilisation.	6	579802257
	<b>Dashboard pressing plate centre, for Weber Standard ram</b>	Ideal addition to rescue rams as a support surface on the centre tunnel and on sills	6	579802241
	<b>Dashboard pressing plate behind, for Weber Standard ram</b>	Ideal addition to rescue rams as a support surface on the centre tunnel and on sills	9,8	579802242
	<b>Stabilisation system Weber STAB-FAST ALUMINIUM</b>	Quantity: 3 Struts, Hook knife, wedge, 2 Transport bags	33	579804596
	<b>Stabilisation system Weber STAB-FAST ALUMINIUM Basic</b>	Quantity: 2 Struts, Hook knife, Transport bag	19	579805122
	<b>Stabilisation system Weber STAB-FAST ALUMINIUM XL</b>	Quantity: 2 Struts, Hook knife, Transport bag	30	579805123
	<b>Set protective covers with Tarpaulin, Weber</b>	Outer material water-repellent and resistant to abrasion. Inner lining cut-proof. Measurements 1.200 x 2.500 mm.	9,2	579802250
	<b>Protective pad set UP-GRADE Weber</b>	Outer material water-repellent and resistant to abrasion. Inner lining cut-proof. Washable.	8,6	579805124
	<b>Weber Patient protection set PAT-SAFE</b>	Patient protection blanket 1600x2000 mm made from CORDURA	1,8	579805127
	<b>Splinter guard, Weber</b>	2 pieces	3,3	579802267

## HYDRAULIC RESCUE SYSTEMS WEBER

Product	Name	Description	Weight (kg)	Part no.
	<b>Rim adapter set small</b>	1x Base plate, 1x Pressure pad RZ, 1x Pressure pad RZT, 1x Pressure pad RZT XL, Transport case	19,6	579802243
	<b>Rim adapter set big</b>	1x rim adapter front wheel, 1x Base plate, 1x Pressure pad RZ, 1x Pressure pad RZT, 1x Pressure pad RZT XL, Transport case	30,7	579802244
	<b>Door opener Set</b>	Max. Spreading force 89 kN Max. Spreading distance 105 mm Weight 16,0 kg	16,5	579802227
	<b>Spring centre punch</b>	for safe removal of single-pane safety glass	0,1	579802144
	<b>s'Heberle</b>	Specially shaped tip for easy removal of interior trim from crashed vehicles. 100 mm long blade made of hardened chrome vanadium steel, impact resistant handle with additional rubber coating for high grip, oil and chemical resistant.	0,1	579802275
	<b>Rescue marker</b>	Round tip, Diameter 10 mm.	0,1	579802896 red 579802897 yellow

## PNEUMATIC RESCUE EQUIPMENT VETTER

Product	Name	Description	Weight (kg)	Part no.
	<b>Super-Mini-HebLifting bag super mini V 1, Aramid, 8 bar</b>	EN 13731, Lifting force max. 1,0 t, Lifting height max. 75 mm	0,5	579801083
	<b>Lifting bag super mini V 3, Aramid, 8 bar</b>	EN 13731, Lifting force max. 3,3 t, Lifting height max. 120 mm	1	579801084
	<b>Lifting bag super mini V 5, Aramid, 8 bar</b>	EN 13731, Lifting force: max. 5,7 t, Lifting height: max. 145 mm	1,4	579801085
	<b>Lifting bag super mini V 6, Aramid, 8 bar</b>	EN 13731, Lifting force: max. 6,4 t, Lifting height: max. 165 mm	1,9	579801086
	<b>Lifting bag mini V 10, Aramid, 8 bar</b>	EN 13731, Lifting force max. 9,6 to, Lifting height max. 203 mm	2,7	579801087
	<b>Lifting bag mini V 12, Aramid, 8 bar</b>	EN 13731, Lifting force: max. 12,0 t, Lifting height: max. 200 mm	3,3	579801088
	<b>Lifting bag mini V 18, Aramid, 8 bar</b>	EN 13731, Lifting force: max. 17,7 t, Lifting height: max. 270 mm	5,1	579801089
	<b>Lifting bag mini V 20, Aramid, 8 bar, without scale</b>	EN 13731, Lifting force max. 19,4 t, Lifting height max. 280 mm.	5,8	579801090
	<b>Lifting bag mini V 24, Aramid, 8 bar</b>	EN 13731, Lifting force: max. 24,0 t, Lifting height: max. 306 mm	6,4	579801091



## PNEUMATIC RESCUE EQUIPMENT VETTER

Product	Name	Description	Weight (kg)	Part no.
	<b>Lifting bag mini V 24 L, Aramid, 8 bar, oblong</b>	EN 13731. Lifting force max. 24,0 t, Lifting height max. 201 mm	6,4	579801092
	<b>Lifting bag mini V 31, Aramid, 8 bar</b>	EN 13731. Lifting force: max. 31,4 t, Lifting height: max. 370 mm	9,4	579801093
	<b>Lifting bag mini V 35 L, Aramid, 8 bar, oblong</b>	EN 13731. Lifting force: max. 35,8 t, Lifting height: max. 310 mm	10	579801094
	<b>Lifting bag mini V 40, Aramid, 8 bar</b>	EN 13731. Lifting force: max. 39,6 t, Lifting height: max. 402 mm	11,6	579801095
	<b>Lifting bag mini V 54, Aramid, 8 bar</b>	EN 13731. Lifting force: max. 54,4 t, Lifting height: max. 478 mm	15,4	579801096
	<b>Lifting bag mini V 68, Aramid, 8 bar</b>	EN 13731. Lifting force: max. 67,7 t, Lifting height: max. 520 mm	19,2	579801097

## PNEUMATIC RESCUE EQUIPMENT VETTER

Product	Name	Description	Weight (kg)	Part no.
	<b>Lifting bag V 1 S.Tec, 12 bar</b>	12bar, Lifting force 13 kN, Lifting height 74 mm, insertion height 25 mm	0,5	579801043
	<b>Lifting bag V 5 S.Tec, 12 bar</b>	12bar, Lifting force 46 kN, Lifting height 121 mm, Insertion height 25 mm	1,3	579801044
	<b>Lifting bag V 7 S.Tec, 12 bar</b>	12bar, Lifting force 75 kN, Lifting height 158 mm, Insertion height 25 mm	2	579801046
	<b>Lifting bag V 10 S.Tec, 12 bar</b>	12bar, Lifting force 101 kN, Lifting height 178 mm, Insertion height 25 mm	2,6	579804387
	<b>Lifting bag V 12 S.Tec, 12 bar</b>	12bar, Lifting force 123 kN, Lifting height 195 mm, Insertion height 25 mm	2,6	579804447
	<b>Lifting bag V 20 S.Tec, 12 bar</b>	12bar, Lifting force 202 kN, Lifting height 245 mm, Insertion height 25 mm	4,8	579804388

## PNEUMATIC RESCUE EQUIPMENT VETTER

Product	Name	Description	Weight (kg)	Part no.
	<b>Lifting bag V 26 S.Tec, 12 bar</b>	12bar, Lifting force 259 kN, Lifting height 270 mm, Insertion height 25 mm	6,2	579806432
	<b>Lifting bag V 33L S.Tec, 12 bar</b>	12bar, Lifting force 333 kN, Lifting height 193 mm, Insertion height 25 mm	8	579801052
	<b>Lifting bag V 35 S.Tec, 12 bar</b>	12bar, Lifting force 347 kN, Lifting height 299 mm, Insertion height 25 mm	8,2	579801053
	<b>Lifting bag V 40 S.Tec, 12 bar</b>	12bar, Lifting force 404 kN, Lifting height 336 mm, Insertion height 25 mm	12,4	579807168
	<b>Lifting bag V 50 S.Tec, 12 bar</b>	12bar, Lifting force 501 kN, Lifting height 375 mm, Insertion height 25 mm	11,9	579801055
	<b>Lifting bag V 59 S.Tec, 12 bar</b>	12bar, Lifting force 594 kN, Lifting height 393 mm, Insertion height 25 mm	13,9	579801054
	<b>Lifting bag V 83 S.Tec, 12 bar</b>	12bar, Lifting force 827 kN, Lifting height 466 mm, Insertion height 25 mm	19,1	579801056

## PNEUMATIC RESCUE EQUIPMENT VETTER



Product	Name	Description	Weight (kg)	Part no.
	<b>Lifting bag V 102 S.Tec, 12 bar</b>	12bar, Lifting force 1016 kN, Lifting height 516 mm, Insertion height 25 mm	23,1	579801057
	<b>Lifting bag VCB 30N C.Tec, 12 bar</b>	Lifting force: max. 301 kN, Lifting height: max. 275 mm, Insertion height: 70mm	12	579807098
	<b>Lifting bag VCB 75N C.Tec, 12 bar</b>	Lifting force: max. 747 kN, Lifting height: max. 435 mm, Insertion height: 70mm	22,4	579818106
	<b>Lifting bag VCB 172N C.Tec, 12 bar</b>	Lifting force: max. 1718 kN, Lifting height: max. 690 mm, Insertion height: 115mm	58	579818107
	<b>Connection plate for Lifting bag VCB</b>		1,2	579804413
	<b>Protective cap for VCB 30</b>			579804410
	<b>Protective cap for VCB 75</b>			579804412
	<b>Protective cap for VCB 172</b>			579818108
	<b>Double operating system AirCU, 8 bar, Deadman, lighting</b>	According EN-13731:2008. Manometer with night illumination, illuminated control panel and Manometer, LEDs in front and back.	3,8	579801098
	<b>Double operating system AirCU lightning</b>	12bar, with Deadman's switch, 1 Inlet- and 2 Outlet manometer	3,8	579804703

TECHNICAL EQUIPMENT

## PNEUMATIC RESCUE EQUIPMENT VETTER



Product	Name	Description	Weight (kg)	Part no.
	<b>Double operating system 8 bar, Fitting</b>	The fitting circuit is manually controlled via a ball valve. Note: Air supply does not stop automatically.	3,1	579801101
	<b>Pressure reducer 200/300 bar</b>	Outlet pressure max. 14 bar	2,5	579804506
	<b>Filling hose 8 bar, 5 m, yellow, SK</b>		1,4	579801104
	<b>Filling hose 8 bar, 5 m, red, SK</b>		1,4	579801105
	<b>Filling hose 8 bar, 10 m, yellow, SK</b>		2,7	579801106
	<b>Filling hose 8 bar, 10 m, red, SK</b>		2,7	579801107
	<b>Filling hose 12 bar S.tec, 5 m, yellow</b>		1,4	579804442
	<b>Filling hose 12 bar S.tec, 5 m, red</b>		1,4	579804446
	<b>Filling hose 12 bar S.tec, 10 m</b>		2,9	579804390
	<b>Filling hose 12 bar S.tec, 10 m</b>		2,9	579804391

## PNEUMATIC RESCUE EQUIPMENT VETTER

Product	Name	Description	Weight (kg)	Part no.
<b>SET LIFTING BAG VETTER 12 BAR</b> Thanks to its intelligent surface profile, you can safely stack two bags and laterally read the maximum lifting power and lifting height. Rounded edges ensure that lifting bags fit in even the narrowest gaps and openings. Aramid-reinforcement guarantees robustness, impeccable temperature behaviour, low wear reduction and aging resistance. Compatible with 8 + 10 bar inflation accessories				
	<b>Lifting bag Set S.Tec 12, 426 kN</b>	12bar, Set consists of Lifting bag (V10,12,20), Filling hoses, double operating system, Pressure reducer	35	579804788
	<b>Lifting bag Set Heavy Rescue 2904 kN, 12 bar</b>	12bar, Set consists of Lifting bag (V10,12,20,33L,35,50,59), Filling hoses, Double operating system, Pressure reducer	55	579804501
<b>SET LIFTING BAG VETTER 8 BAR</b> With an insertion height of only 2.5 cm (0.98 inch), the lifting bag fits in even the narrowest gaps and openings. The optimised surface profile enables good stability on slippery grounds. Thanks to special security couplings, hoses and lifting bags cannot be detached by accident.				
	<b>Lifting bag Mini Set, 393KN, 8 bar Aramid, AirCU with illumination</b>	Contains Lifting bag V 10, V 12, V 18. 2x Filling hose 5m, Double operating system, Pressure reducer	21	579801110
	<b>Lifting bag Mini Set, 873KN, 8 bar Aramid, AirCU with illumination</b>	Contains Lifting bag V 10, V 12, V 18, V 24, V 24 L, 2x Filling hose 5m, Double operating system, Pressure reducer	34	579801111
	<b>Lifting bag Mini Set, 2804KN, 8 bar Aramid, AirCU with illumination</b>	Contains Lifting bag V10, V12, V18, V24, V24 L, V31, V40, V54, V68, 2x Filling hose 5m, Double operating system, Pressure reducer	90	579801112

TECHNICAL EQUIPMENT

## PNEUMATIC RESCUE EQUIPMENT VETTER

Product	Name	Description	Weight (kg)	Part no.
	<b>Ultra Flat Lifting bag UF 1, 8 bar, with smooth surface</b>	EN 13731, Lifting force: max. 1,0 t, Lifting height: max. 75 mm	0,3	579801133
	<b>Ultra Flat Lifting bag UF 3, 8 bar, with smooth Surface</b>	EN 13731, Lifting force: max. 3,3 t, Lifting height: max. 120 mm	0,7	579801134
	<b>Ultra Flat Lifting bag UF 6, 8 bar, with smooth Surface</b>	EN 13731, Lifting force: max. 6,4 t, Lifting height: max. 165 mm	1,2	579801135
	<b>Ultra Flat lifting bag UF 10, 8 bar, with smooth Surface</b>	EN 13731, Lifting force: max. 9,6 t, Lifting height: max. 203 mm	1,7	579801136
	<b>Wedge lifting bag Set, 1 bar, AirCU Deadman with illumination</b>	Rescue of trapped individuals from thin-walled coachwork, lifting overturned vehicles. Preparation for up righting with lifting bags.	39,6	579801137

### LIFTING BAG-SET VETTER 1 BAR

The lifting bags are made from neoprene coated nylon fabric, the walls from highly tear-proof aramid. In addition, the bags are fitted with 8 carrying and fixing loops. Lifting bags are connected via quick-closing couplings.

	<b>Lifting bag Set Type 1/23, 1,0 bar, AirCU Deadman lighting</b>	Contains: 2x Lifting bag, 2x Filling hose 5m, Double operating system, Pressure reducer. Lifting force: 22,6t - Lifting height 127 cm	55	579801139
	<b>Lifting bag Set Type 1/13, 1,0 bar with Air-CU, Deadman lighting</b>	Contains: 2x Lifting bag, 2x Filling hose 5m, Double operating system, Pressure reducer. Lifting force: 13,0 t - Lifting height: 62 cm	37	579801140
	<b>Lifting bag Set Type 1/9, 1,0 bar with Air- CU, Deadman lighting</b>	Contains: 2x Lifting bag, 2x Filling hose 5m, Double operating system, Pressure reducer. Lifting force: 9,0 t - Lifting height: 60 cm	31	579801141
	<b>Lifting bag Set Type 1/6, 1,0 bar with Air- CU, Deadman lighting</b>	Contains: 2x Lifting bag, 2x Filling hose 5m, Double operating system, Pressure reducer. Lifting force: 5,8 t - Lifting height: 45 cm	25	579801142
without image	<b>Rescue set 1,0 bar with AirCU, Deadman with Illumination</b>	Contains: 2x pressure pad, 2x Filling hose 5m, Double operating system, Pressure reducer, repair work kit. Lifting force: 12,1 t - Lifting height: 65 cm	33,8	579801143

## PNEUMATIC RESCUE EQUIPMENT VETTER

Product	Name	Description	Weight (kg)	Part no.
	<b>Leak sealing bag Set LD 50/30 W, 1,5 bar, with swivel eyes</b>	Contains: Sealing bag 50x30cm, Foot pump, Filling hose 10m, 2x Lashing strap 2m, 2x Lashing strap 10m, 2x Inflation hose 5m, 2x anti-expansion cover plate, Cover, Bag	31,3	579801163
	<b>Leak sealing bag Set LD 50/30 S, 1,5 bar, Clamping slot</b>	Contains: Sealing bag 50x30cm, Foot pump, Filling hose 10m, 4x lashing strap 10m, 2x Anti-expansion cover plate, Cover, Bag	26,5	579801164
	<b>Leak sealing bag Set LD 110/60 S XL 1,5 bar, Clamping slot</b>	Contains: Sealing bag 86x57cm, control system, Filling hose 10m, 6x Lashing strap 10m, 2x anti-expansion cover plate, Cover	39,5	579801165
	<b>Leak sealing bandage LB 5-20 1,5 bar</b>	incl. Hose spacer, Measurements: 98 x 21 cm, Sealing diameter: 19 cm wide	3,3	579801166
	<b>Leak sealing bandage LB 20-48 1,5 bar</b>	incl. Strap spacer, Measurements: 177 x 21 cm, Sealing diameter: 19 cm wide	5,1	579801167
	<b>Leak sealing bandage LB 5-20 XL 1,5 bar</b>	Measurements: 100 x 40 cm, Sealing diameter: 38 cm wide	6,1	579801168
	<b>Foot pump</b>	with safety valve, 1,5 bar	2,7	579801169
	<b>Filling hose 1,5 bar, 10 m, blue</b>		2,8	579801170
	<b>Single operating system, 1,5 bar, Fitting Vetter</b>	Air supply does not stop automatically. According EN 13731, this part is not authorized for use by fire departments within the EU.	1,3	579801171



## PNEUMATIC RESCUE EQUIPMENT VETTER

Product	Name	Description	Weight (kg)	Part no.
	<b>Mini leak sealing bag Set 1,5 bar</b>	For leaks in small containers with a diameter between 10 and 90 cm, securely seals liquids and gases. Attached with Velcro belt.	8,6	579801173
	<b>Leak sealing lance set 1,5 bar, with foot pump</b>	One-person operation, inflatable with foot pump, 140cm lance length, shut-off unit prevents pressure drop and air leakage when decoupling.	6,6	579801174
	<b>Leak sealing paste set</b>	All-round product for leaking acids, brine, emulsions, as well as slightly oily surfaces.	5,9	579801178
	<b>Leak drainage bags Set 1,5 bar</b>	Sealing/drainage of hazardous substances in tank trucks and wagons, large drums, and pipes. Inflatable with foot pump. Drainage space 40x20x2,5cm	38	579801181
	<b>Vacuum leak drainage bag Set DLD 50 VAC</b>	Sealing/drainage of hazardous substances on smooth surfaces of large containers and storage tanks.	14	579801183
	<b>Flange drain bag Set DN 50, 1,5 bar - for Pipes with DN 50</b>	Flange drain bags cover the flange and pipe, reliably stop the leakage of hazardous liquids and at the same time allow you to drain off the liquid in a controlled and safe manner.	16,3	579801188

## PNEUMATIC RESCUE EQUIPMENT VETTER

Product	Name	Description	Weight (kg)	Part no.
	<b>Pipe sealing bag RDK 7/15 FS, CR, 1,5 bar</b>	for Pipes with diameter 7 - 15 cm, Cylinder length 30,0 cm, Total length 34,5 cm, Ø 6,8 cm	0,5	579801191
	<b>Pipe sealing bag RDK 10/20 FS, CR, 1,5 bar</b>	for Pipes with diameter 10 - 20 cm, Cylinder length 51,0 cm, Total length 55,5 cm, Ø 9,0 cm	0,8	579801192
	<b>Pipe sealing bag RDK 20/40 FS, CR, 1,5 bar</b>	for Pipes with diameter 20 - 40 cm, Cylinder length 65,5 cm, Total length 70,5 cm, Ø 19,5 cm	3,4	579801193
	<b>Pipe sealing bag RDK 30/60 FS, CR, 1,5 bar</b>	for Pipes with diameter 30 - 60 cm, Cylinder length 73,5 cm, Total length 78,0 cm, Ø 29,5 cm	7,1	579801194
	<b>Pipe sealing bag RDK 50/100 FS, CR, 1,5 bar</b>	for Pipes with diameter 50 - 100 cm, cylinder length 111,0 cm, Total length 117,0 cm, Ø 45,0 cm	18	579801195
	<b>Pipe sealing bag RDK 80/140 FS, CR, 1,5 bar</b>	for Pipes with diameter 80 - 140 cm, cylinder length 181,0 cm, Total length 185,5 cm, Ø 78,5 cm	58,4	579801196

### GULLY SEALING BAG SET VETTER





Quickly seal gullies. Inflate sealing bags fast and self-sufficient through foot pump, fitted with manometer and safety valve.

	<b>Basic Set Universal Gully Sealing bag, 2,5 bar</b>	Stop the flow of chemical leaks, flooding, and seal gullies with diameter 10 - 15 cm.	11,9	579801203
	<b>Premium set Vetter Universal Gully Sealing bag 2,5 bar</b>	Stop the flow of chemical leaks, flooding, and seal gullies with diameter 10 - 30 cm.	15,6	579801204
	<b>Compact Gully Sealing bag Set 0,5 bar for compressed air inflation</b>	Stop the flow of chemical leaks, flooding, and seal gullies with diameter 30 - 50 cm.	10,3	579801205

## ACCESSORIES PNEUMATIC RESCUE EQUIPMENT VETTER

Product	Name	Description	Weight (kg)	Part no.
	<b>Fill and Safety fitting 0,5 bar</b>	for Sealing bag Gully Compact	1,3	579801207
	<b>Connector kit Vetter</b>	Universal set	6,2	579801208
	<b>Truck break connector, 2 circuits</b>		0,3	579801209
	<b>Sealing-off cap</b>		0,3	579801210
	<b>Truck tyre inflation system</b>		0,1	579801211
	<b>Truck tyre valve</b>		0,1	579801212
	<b>Truck tyre valve con- nector</b>	Clamp-on design	0,1	579801213
	<b>Compressor-air mains connector</b>	Mains connector	0,03	579801214
	<b>Construction-site com- pressor adaptor</b>		0,2	579801215







## ACCESSORIES PNEUMATIC RESCUE EQUIPMENT VETTER

Product	Name	Description	Weight (kg)	Part no.
	<b>Inflation hose 10 m, green</b>	10 m, green with shut-off unit	2,7	579801217
	<b>Gully-Ei® Type A System Sion</b>	Volume 4,8 l, inflation with pressure of 0,1–0,2 bar	4	579804624
	<b>Fill fitting for Gully-Ei® Type A</b>	with safety and connection valve	2,5	579804626
	<b>Transport case Sion</b>	To contain one SION Gully-Ei with Accessories.		579815153







## CHAINSAWS HUSQVARNA

Product	Name	Description	Weight (kg)	Part no.
	<b>Petrol chainsaw 550 XP 38 cm, .325", Husqvarna</b>	Cylinder displacement 50,1 cm <sup>3</sup> , Sound pressure level 106 dB(A), Sound power level 116 dB(A)	4,9	579804609
	<b>Petrol chainsaw 550 XP Mark II, 45 cm, .325", Husqvarna</b>	Cylinder displacement 50,1 cm <sup>3</sup> , Sound pressure level 106 dB(A), Sound power level 116 dB(A)	4,9	579808038
	<b>Petrol chainsaw 555 XP 45 cm, 325", Husqvarna</b>	Power: 3,0 (4,0) kW (PS), Cylinder displacement 50,1 cm <sup>3</sup> , Sound pressure level 106 dB(A), Sound power level 116 dB(A)	5,6	579816950
	<b>Petrol chainsaw 560 XP 38 cm, 325", Husqvarna</b>	Power: 3,5(4,8) kW(PS), Cylinder displacement 59,8 cm <sup>3</sup> , Sound pressure level 106 dB(A), Sound power level 118 dB(A)	5,9	579816951
	<b>Petrol chainsaw 560 XP G 38 cm, 325", Husqvarna</b>	Power: 3,5(4,8) kW(PS), Cylinder displacement 59,8 cm <sup>3</sup> , Sound pressure level 106 dB(A), Sound power level 118 dB(A), heated handle	5,9	579816952
	<b>Petrol chainsaw 572 XP 45 cm, 3/8", Husqvarna</b>	Power: 4,3(5,8) kW(PS), Cylinder displacement 70,6 cm <sup>3</sup> , Sound pressure level 107 dB(A), Sound power level 120 dB(A)	6,6	579816953
	<b>Petrol chainsaw 585 XP 60 cm, 3/8", Husqvarna</b>	Power: 5,1(6,8) kW(PS), Cylinder displacement 86 cm <sup>3</sup> , Sound pressure level 112 dB(A), Sound power level 119 dB(A)	7,5	579816975
	<b>Petrol chainsaw 592 XP 60 cm, 3/8", Husqvarna</b>	Power: 5,6(8,0) kW(PS), Cylinder displacement 92,7 cm <sup>3</sup> , Sound pressure level 112 dB(A), Sound power level 119 dB(A)	7,5	579816976
	<b>Battery chainsaw 535i XP® 35cm, 325"mini Husqvarna</b>	Battery voltage: 36 V, Chain type SP21G, Chain speed: 20 m/s, Sound power level: 93 dB(A), Sound power level: 106 dB(A)	2,4	579815662
	<b>Battery chainsaw T535i XP 35cm, 325"mini Husqvarna</b>	Battery voltage: 36 V, Chain type SP21G, Chain speed: 20 m/s, Sound power level: 93 dB(A), Sound power level: 106 dB(A)	2,4	579809939

## CHAINSAWS HUSQVARNA

Product	Name	Description	Weight (kg)	Part no.
without image	<b>Replacement chainsaw chain SP21G, 35cm</b>		0,3	579815663
	<b>Battery chainsaw 540i XP 40 cm, 325\" mini Husqvarna</b>	Battery voltage: 36 V, Chain type SP21G, Chain speed: 24 m/s, Sound power level: 95 dB(A), Sound power level: 106 dB(A)	2,9	579816164
without image	<b>Replacement chainsaw chain X- CUT SP21G 40 cm</b>		0,3	579816490
	<b>Battery chainsaw T540i XP 35 cm, 325\" mini Husqvarna</b>	Battery voltage: 36 V, Chain type SP21G, Chain speed: 24 m/s, Sound power level: 92 dB(A), Sound power level: 103 dB(A)	2,5	579816977
	<b>Battery Husqvarna Bli200</b>	Battery capacity 5 Ah, Battery type Li-Ion, Power 180 Wh	1,3	579808223
	<b>Battery Husqvarna Bli300</b>	Battery capacity 9,4 Ah, Battery type Li-Ion, Power 337 Wh	1,9	579816165
	<b>Battery Husqvarna Bli200X</b>	Battery capacity 5 Ah, Battery type Li-Ion, Power 180 Wh	1,3	579816988
	<b>Battery fast charger QC330</b>	Voltage 200-240V, Frequency 50-60 Hz, 330W	1,5	579809940
	<b>Battery fast charger QC500</b>	Voltage 220-240V, Frequency 50-60 Hz, 500W	1,5	579808486

## CHAINSAWS STIHL







Product	Name	Description	Weight (kg)	Part no.
	<b>Petrol chainsaw Stihl MS 251</b>	Bar length: 40cm, Cylinder displacement: 45,6cm <sup>3</sup> , Power: 2,2kW, Sound pressure level: 103dB(A), Sound power level: 114 dB(A), Chain pitch: 325"	4,8	579804560
	<b>Replacement chainsaw chain Stihl Rapid Micro 3 (RM3)</b>	Chain pitch: 325", Drive link thickness 1,6 mm, for Bar length 40cm	0,29	579804741
	<b>Petrol chainsaw Stihl MS 261 C-M</b>	Bar length: 37cm, Cylinder displacement: 50,2cm <sup>3</sup> , Power: 3kW, Sound pressure level: 104dB(A), Sound power level: 116 dB(A), Chain pitch: 325"	5,1	579805253
	<b>Replacement chainsaw chain Rapid Super (RS)</b>	Chain pitch: 325", Drive link thickness 1,6 mm, for Bar length 37 & 40cm	0,29	579805599
	<b>Petrol chainsaw Stihl MS 261 C-M</b>	Bar length: 40cm, Cylinder displacement: 50,2cm <sup>3</sup> , Power: 3kW, Sound pressure level: 104dB(A), Sound power level: 116 dB(A), Chain pitch: 325"	4,9	579805198
	<b>Replacement chainsaw chain Rapid Super</b>	Chain pitch: 325", Drive link thickness 1,6 mm, for Bar length 40cm except MS 251		579801860
	<b>Petrol chainsaw Stihl MS 261 C-BM</b>	Bar length: 40cm, Cylinder displacement: 50,2cm <sup>3</sup> , Power: 3kW, Sound pressure level: 104dB(A), Sound power level: 116dB(A), Chain pitch: 325"	5,1	579805024
	<b>Replacement chainsaw chain Rapid Super</b>	Chain pitch: 325", Drive link thickness 1,6 mm, for Bar length 40cm except MS 251		579801860
 	<b>Petrol chainsaw MS 291</b>	Bar length: 40cm, Cylinder displacement: 55,5cm <sup>3</sup> , Power: 2,8kW, Sound pressure level: 103dB(A)	5,6	579804778
	<b>Replacement chainsaw chain Stihl Rapid Micro 3 (RM3)</b>	Chain pitch: 325", Drive link thickness 1,6 mm, for Bar length 40cm	0,29	579804741
	<b>Petrol chainsaw Stihl MS 291 C-BE</b>	Sound power level: 116 dB(A), Chain pitch: 3/8"		579806289
	<b>Petrol chainsaw Stihl MS 311</b>	Bar length: 40cm, Cylinder displacement 59 cm <sup>3</sup> , Power: 3,1kW, Sound pressure level 105 dB(A), Sound power level 117 dB(A), Chain pitch: 3/8"	6,2	579805563
	<b>Replacement chainsaw chain Stihl Rapid Micro (RM)</b>	Chain pitch: 3/8", Drive link thickness 1,6 mm, for Bar length 40cm	0,29	579805544

## CHAINSAWS STIHL



Product	Name	Description	Weight (kg)	Part no.
	<b>Petrol chainsaw Stihl MS 362 C-M</b>	Bar length: 37cm, Cylinder displacement: 59cm <sup>3</sup> , Power: 3,5kW, Sound pressure level: 106dB(A), Sound power level: 117 dB(A), Chain pitch: 3/8" Rapid Super	6,7	579806254
	<b>Replacement chainsaw chain Stihl Rapid Super</b>	Chain pitch: 3/8", Drive link thickness 1,6 mm, for Bar length 37cm	0,32	579806255
	<b>Petrol chainsaw Stihl MS 362 C-M</b>	Bar length: 40cm, Cylinder displacement: 59cm <sup>3</sup> , Power: 3,5kW, Sound pressure level: 106dB(A), Sound power level: 117 dB(A), Chain pitch: 3/8" Rapid Super	6,7	579801861
	<b>Petrol chainsaw Stihl MS 362 C-M</b>	Bar length: 40cm, Cylinder displacement: 59cm <sup>3</sup> , Power: 3,5kW, Sound pressure level: 106dB(A), Sound power level: 117dB(A), Chain pitch: 3/8" Rapid Super	5,6	579805145
	<b>Replacement chainsaw chain Stihl Rapid Duro 3</b>	Chain pitch: 3/8", Drive link thickness 1,6 mm, for Bar length 40cm	0,45	579805146
	<b>Petrol chainsaw MS 362 C-M</b>	Bar length: 45cm, Cylinder displacement: 59cm <sup>3</sup> , Power: 3,5kW, Sound pressure level: 105dB(A), Sound power level: 117dB(A), Chain pitch: 3/8" for Blade length 45cm, Chain pitch 3/8"	5,6	579805271
	<b>Replacement chainsaw chain Stihl Rapid Super 3</b>		0,45	579805366
	<b>Petrol chainsaw Stihl MS 391</b>	Bar length: 40cm, Cylinder displacement 64,1cm <sup>3</sup> , Power: 3,3kW, Sound pressure level 105 dB(A), Sound power level 117 dB(A), Chain pitch: 3/8"	6,2	579805543
	<b>Replacement chainsaw chain Stihl Rapid Micro (RM)</b>	Chain pitch: 3/8", Drive link thickness 1,6 mm, for Bar length 40cm	0,29	579805544
	<b>Petrol chainsaw MS 462 C-M</b>	Bar length: 40cm, Cylinder displacement: 72,2cm <sup>3</sup> , Power: 4,4kW, Sound pressure level: 108dB(A), Sound power level: 119 dB(A), Chain pitch: 3/8" Chain pitch: 3/8", Drive link thickness 1,6 mm, for Bar length 40cm	7,2	579807145
	<b>Replacement chainsaw chain Stihl Rapid Super</b>		0,32	579801864
	<b>Petrol chainsaw MS 500i</b>	Cylinder displacement: 79,2 cm <sup>3</sup> , Power: 5,0/6,8 kW/ PS, Sound pressure level: 106 dB(A), Sound power level: 119 dB(A), Bar length: 50cm	6,2	579808417
	<b>Replacement chainsaw chain Stihl Rapid Super</b>	for Blade length 50cm, Chain pitch 3/8"		579806284
	<b>Petrol chainsaw MS 500i</b>	Cylinder displacement: 79,2 cm <sup>3</sup> , Power: 5,0/6,8 kW/ PS, Sound pressure level: 106 dB(A), Sound power level: 119 dB(A), Bar length: 63cm	6,4	579808418
	<b>Replacement chainsaw chain Stihl Rapid Super (RS)</b>	Chain pitch: 3/8", Drive link thickness 1,6 mm, for Bar length 63cm		579806082



## CHAINSAWS STIHL

Product	Name	Description	Weight (kg)	Part no.
	<b>Electric chainsaw Stihl MSE 170 C-BQ</b>	Bar length: 30cm, Rated voltage: 230V, Power consumption: 1,7kW, Sound pressure level: 92dB(A), Sound power level: 103dB(A), Chain pitch: 3/8" P	4,3	579805025
	<b>Replacement chainsaw chain Stihl Picco Micro 3 (PM3)</b>	Chain pitch: 3/8"P, Drive link thickness 1,3 mm, for Bar length 30cm	0,2	579805026
	<b>Electric chainsaw Stihl MSE 170 C-BQ</b>	Bar length: 35cm, Rated voltage: 230V, Power consumption: 1,7kW, Sound pressure level: 92 dB(A), Sound power level: 103dB(A), Chain pitch: 3/8"		579804519
	<b>Replacement chainsaw chain Stihl Picco Micro Mini 3 (PMM3)</b>	Chain pitch: 3/8", Drive link thickness 1,1 mm, for Bar length 35cm	0,29	579804742
	<b>Electric chainsaw Stihl MSE 190 C-BQ</b>	Bar length: 30cm, Rated voltage: 230V, Power consumption: 1,9kW, Sound pressure level: 92dB(A), Sound power level: 103 dB(A), Chain pitch: 3/8" P Bar length: 35cm	4,5	579804708 579804084
	<b>Replacement chainsaw chain Stihl Picco Micro 3 (PM3)</b>	Chain pitch: 3/8"P, Drive link thickness 1,3 mm, for Bar length 30cm for Blade length 35cm, Chain pitch 3/8"	0,2 0,2	579805026 579805904
	<b>Electric chainsaw Stihl MSE 230 C-BQ</b>	Bar length: 40cm, Rated voltage: 230V, Power consumption: 2,3kW, Sound pressure level: 93 dB(A), Sound power level: 104 dB(A), Chain pitch: 3/8"	4,8	579801865
	<b>Replacement chainsaw chain Picco Micro 3 (PM3)</b>	Chain pitch: 3/8", Drive link thickness 1,3 mm, for Bar length 40cm	0,2	579801866
	<b>Electric chainsaw Stihl MSE 250 C-Q</b>	Bar length: 40cm, Rated voltage: 230V, Power consumption: 2,5kW, Sound pressure level: 94 dB(A), Sound power level: 105 dB(A), Chain pitch: 3/8"	5,8	579801867
	<b>Replacement chainsaw chain Rapid Micro 3 (RM 3)</b>	Chain pitch: 3/8", Drive link thickness 1,6 mm, for Bar length 40cm	0,29	579805037
	<b>Battery chainsaw MSA 120 C-BQ</b>	Bar length: 30cm, Rated voltage: 36V, Sound power level: 94dB(A), Chain pitch: 1/4", incl Battery AK20 and Charger AL101	2,7	579807209
	<b>Battery chainsaw Stihl MSA 200 C-BQ</b>	Bar length: 35cm, Rated voltage: 36V, Sound power level: 95dB(A), Chain pitch: 1/4"	3,3	579807416
	<b>Replacement chainsaw chain Stihl Picco Micro 3</b>	Chain pitch: 1/4", Drive link thickness 1,1 mm, for Bar length 35cm	0,21	579807417

## CHAINSAWS STIHL

Product	Name	Description	Weight (kg)	Part no.
	<b>Pole pruner STIHL HTE 60</b>	Bar length: 30cm, Power consumption: 1,4 kW, Sound pressure level: 90dB(A), Sound power level: 102 dB(A), Chain pitch: 3/8"	5,1	579806920
	<b>Replacement chainsaw chain Stihl Picco Micro Mini 3 (PMM3)</b>	Chain pitch: 3/8", Drive link thickness 1,1 mm, for Bar length 30cm	0,2	579806922
	<b>Protective feet for HTA</b>		1	579806310

### EMERGENCY SERVICES SAW STIHL

Perfectly suited to the toughest jobs for fire services, emergency services and technical assistance teams, with extremely cut-resistant material. Additional handle for quick and easy adjustment of cutting depth; large starter grip. Special Rapid Duro R saw chain with plating made from impact-resistant carbide blades. STIHL M-Tronic with calibration function always guarantees optimal engine performance and easy starting. Controlled-delivery high-performance oil pump for high pumping capacity, HD2 filter with radial seal, tool-free fuel caps for simple, safe refuelling.

	<b>Petrol chainsaw Stihl MS 462 C-M R</b>	Cylinder displacement: 72,2 cm <sup>3</sup> , Power: 4,4/6 kW/PS, Sound pressure level: 108 dB(A), Sound power level: 119 dB(A), Chain pitch: 3/8"	6,5	579807946
	<b>Replacement chainsaw chain Rapid Duro R (RDR) Stihl 50 cm 3/8"</b>		0,45	579801892

## ACCESSORIES CHAINSAWS

Product	Name	Description	Weight (kg)	Part no.
	<b>Battery STIHL AP200</b>	Capacity 187 Wh, Rated voltage 36 V, Battery capacity 4,8 Ah, Nominal cell capacity 5,2 Ah	1,7	579807099
	<b>Battery STIHL AP 300</b>	Capacity 227 Wh, Rated voltage 36 V, Battery capacity 6 Ah, Nominal cell capacity 6,3 Ah		579805653
	<b>Battery Stihl AK 20</b>	Capacity 144Wh, Rated voltage 36V, Nominal cell capacity 2,1Ah	0,7	579807211
	<b>Quick charger STIHL AL 300</b>	Battery charge time AP 300 75 min, Charging current 6,5 A, Rated voltage 220-240/50 V/Hz, Battery voltage 36 V	1,2	579805655
	<b>Battery-Charger Stihl AL 101</b>	Voltage: 230 V, Power consumption: 0,1 kW, Charging current: 1,6 A	0,7	579808470
	<b>Quick charger Stihl AL 500</b>	Battery-Charge time AP 300 35 min, Charging current 12A, Rated voltage 220-240/50 V/Hz, Battery voltage 36 V	1,3	579807414
	<b>Felling &amp; cleaving wedge Stihl Aluminium small 215 mm</b>		0,6	579801872
	<b>Felling &amp; cleaving wedge Stihl Aluminium medium</b>		0,8	579801873
	<b>Felling &amp; cleaving wedge Stihl Aluminium large</b>		1	579801874





## ACCESSORIES CHAINSAWS

Product	Name	Description	Weight (kg)	Part no.
	<b>Felling &amp; cleaving wedge Stihl Plastic 190 mm</b>		0,16	579801875
	<b>Felling &amp; cleaving wedge Stihl Plastic 230 mm</b>		0,27	579801876
	<b>Felling &amp; cleaving wedge Stihl Plastic 250 mm</b>		0,41	579801877
	<b>Twisted splitting wedge</b>		0,92	579801871
	<b>Cant hook small</b>	High-strength, lightweight steel, square tube. Handle made from thermoplastic resin. Especially suitable for arborists.	0,74	579805672
	<b>Hand lifting tongs STIHL FP 20</b>	Jaw size 20 cm. For moving wood, with an angled comfort handle. Hardened tips.	0,3	579806470
	<b>Cant hook STIHL, big</b>	With hook to turn heavy logs.	3,4	579806860
	<b>Hand hookaroon Stihl</b>	German design. Reinforced.	0,5	579807065
	<b>Beaver hookaroon Stihl</b>	For shifting and moving logs.	1,3	579807066







## ACCESSORIES CHAINSAWS

Product	Name	Description	Weight (kg)	Part no.
	<b>ASPEN 2 Fuel for air-cooled two-stroke engines</b>	For chainsaws, clearing saws, power cutters, mopeds, hedge trimmers, and other engines mainly used on land, 5 litre canister.	5,2	579804701
	<b>SynthPlus chain oil Stihl 1 Litre</b>	Outstanding protection against wear and tear.	0,96	579801897
	<b>Combination canister Stihl Standard Fuel/oil, orange, unfilled</b>	Twin canister for 5 Litre Fuel and 3 Litre Chain oil. UN approved.	1,49	579801893
	<b>Combination canister Stihl Perf, Fuel/oil, orange, unfilled</b>	Twin canister for 5 Litre Fuel and 3 Litre Chain oil. Incl. 2 holders for storing stools/filling system. UN approved.	1,61	579801894
	<b>Filling system Stihl Chain oil</b>	For Stihl Combination canister, Ø 23 mm.	0,14	579801895
	<b>Filling system Stihl Fuel</b>	For Stihl Combination canister and Fuel canister.	0,11	579801896

## SEPARATING TOOLS HUSQVARNA

Product	Name	Description	Weight (kg)	Part no.
	<b>Cutter Husqvarna K 970</b>	<p>Sturdy, reliable, light, and powerful - the K 970 power cutter is ready to perform when you are. The ultimate choice when you need an all-round cutter performing in the toughest conditions, withstanding climate, and fuel variations. Suitable for road works when used with the corresponding KV 970 trolley. The trolley also means you can fully concentrate on the cutting job.</p> <p>Power: 4,8kW, Cylinder displacement: 93,6cm<sup>3</sup>, 2 stroke engine, max. Cutting depth: 125mm, max. Blade diameter: 350mm, Max. Blade thickness: 5 mm, Speed max. 90 m/s, Sound power level: 115 dB(A), Sound pressure level:104 dB(A)</p>	10,9	579816989
	<b>Cutter Husqvarna K 770</b>	<p>Power: 3,7kW, Cylinder displacement: 73,5cm<sup>3</sup>, 2 stroke engine, max. Cutting depth: 125mm, max. Blade diameter: 350mm</p>	10,1	579816990
	<b>Battery cutter Husqvarna K 1 PACE Rescue</b>	<p>K 1 PACE high power battery cutter has the power and performance you expect from equivalent petrol-powered cutters. Equipped with X-Halt™ brake function for operational safety. Ergonomic and user-friendly with low vibrations, optimally balanced machine and zero CO<sub>2</sub> emissions during use. With built-in connectivity so you can easily monitor machine location, runtime, service intervals and receive wireless updates through FOTA (firmware over the air). Powered by Husqvarna PACE battery system with high power and fast charging for impressive productivity and a well-suited match with our specially designed battery blade range for maximised cutting depth and optimised performance.</p> <p>Max. Cutting depth: 145mm, max. Blade diameter: 361mm, Speed max. 59m/s, Sound power level 112,9dB(A), Sound pressure level 101,9dB(A), Tap connector Gardena Male, without batteries &amp; charger</p>	7,9	579816997
	<b>Battery cutter Husqvarna K 1 PACE</b>	<p>max. Cutting depth: 145mm, max. Blade diameter: 361mm, Speed max. 59m/s, Sound power level 112,9dB(A), Sound pressure level 101,9dB(A), Tap connector Gardena Male, without batteries &amp; charger</p>	7,4	579816993
	<b>Battery cutter Husqvarna K 1 PACE Kit</b>	<p>max. Cutting depth: 145mm, max. Blade diameter: 361mm, incl. 2x Battery B380X &amp; Charger C900X</p>		579816992

## SEPARATING TOOLS HUSQVARNA

Product	Name	Description	Weight (kg)	Part no.
	<b>Battery cutter Husqvarna K 535i</b>	Power: 1,2kW, Battery, max. Cutting depth: 76mm, max. Blade diameter: 230mm, Sound pressure level: 100,5 dB(A)	3,5	579816991
	<b>Battery cutter Husqvarna Bli200</b>	Battery capacity 5 Ah, Battery type Li-Ion, Power 180 Wh	1,3	579808223
	<b>Battery cutter Husqvarna Bli300</b>	Battery capacity 9,4 Ah, Battery type Li-Ion, Power 337 Wh	1,9	579816165
	<b>Battery cutter Husqvarna B380X PACE</b>	Battery capacity 4 Ah, Battery type Li-Ion, Power 375 Wh, Voltage 94 V	1,9	579816995
	<b>Charger QC330</b>	Voltage 200-240V, Frequency 50-60 Hz, 330W	1,5	579809940
	<b>Quick charger QC500</b>	Voltage 220-240V, Frequency 50-60 Hz, 500W	1,5	579808486
	<b>Quick charger Husqvarna C900X PACE</b>	C900X PACE is a high power battery charger with a capacity of 900 W suitable for B380X and B750X PACE batteries. Equipped with a fast charging mode and active cooling enables fast charging of batteries.	1,3	579816996

## SEPARATING TOOLS STIHL

Product	Name	Description	Weight (kg)	Part no.
	<b>Cordless cut-off Stihl TSA 230</b>	Sound power level 114 dB(A), Battery-Operating time with AP 300 up to 18 min, without Battery and Charger	3,9	579805922
	<b>Petrol cut-off machine Stihl TS 410</b>	for cutting wheel Ø 300 mm, Cutting depth 100 mm, Performance 3,2 kW, Cylinder displacement 66,7 cm <sup>3</sup> , Sound power level 109 dB(A)	9,5	579805404
	<b>Petrol cut-off machine Stihl TS 420</b>	for Cutting wheel Ø 350 mm, Cutting depth 125 mm, Performance 3,2 kW, Cylinder displacement 66,7 cm <sup>3</sup> , Sound power level 109 dB(A)	10	579804520
	<b>Petrol cut-off machine Stihl TS 480i</b>	for Cutting wheel Ø 300 mm, Cutting depth 100 mm, Performance 3,9 kW, Cylinder displacement 72,2 cm <sup>3</sup> , Sound power level 112 dB(A)	10	579801878
	<b>Petrol cut-off machine TS 500i</b>	for Cutting wheel Ø 350 mm, Cutting depth 125 mm, Performance 3,9 kW, Cylinder displacement 72,2 cm <sup>3</sup> , Sound power level 112 dB(A)	10,2	579801879
	<b>Petrol cut-off machine TS 700</b>	for Cutting wheel Ø 350 mm, Cutting depth 125 mm, Performance 5,0 kW, Cylinder displacement 98,5 cm <sup>3</sup> , Sound power level 113 dB(A)	11,7	579801880
	<b>Petrol cut-off machine TS 800</b>	for Cutting wheel Ø 400 mm, Cutting depth 145 mm, Performance 5 kW, Cylinder displacement 98,5 cm <sup>3</sup> , Sound power level 113 dB(A)	12,7	579801881
	<b>Angle grinder Bosch GWS 22-230 JH Professional „Fire brigade“</b>	Power 2200 W, Grinding spindle thread M 14, straight steel handle. Disc Ø 230 mm.	7,2	579803132





## ACCESSORIES SEPARATING TOOLS

Product	Name	Description	Weight (kg)	Part no.
	<b>Reciprocating saw Bosch GSA 1300 PCE Professional, Firefighting application</b>	Power 1300 W. Stroke length 28 mm. Cutting depth in Wood 220 mm. Cutting depth in metal, profiles, and pipes 20 mm.	3,7	579803105
	<b>Cutting wheel for metal, 230 mm</b>	Application Separation. Drill Ø22 mm.	0,3	579803133
	<b>Cutting wheel for stone, 230 mm</b>	Application Separation. Drill Ø22 mm.	0,1	579803134
	<b>Abrasive wheel Synthetic resin, K-BA, 300 mm</b>	for Stone, Concrete, Aluminium, Non-ferrous metal Min. order quantity: 10 pieces!	0,54	579801882
	<b>Abrasive wheel Synthetic resin, K-ME, 300 mm</b>	for Steel Min. order quantity: 10 pieces!	0,6	579801884
	<b>Abrasive wheel Stihl Synthetic resin, K-BA, 350 mm</b>	for Stone, Concrete, Aluminium, Non-ferrous metal Min. order quantity: 10 pieces!	0,81	579801885
	<b>Abrasive wheel Stihl Synthetic resin, K-ME, 350 mm</b>	for Steel Min. order quantity: 10 pieces!	0,87	579801887
	<b>Abrasive wheel Synthetic resin, K-BA, 400 mm</b>	for Stone, Concrete, Aluminium, Non-ferrous metal Min. order quantity: 10 pieces!	1,02	579801888
	<b>Abrasive wheel Synthetic resin, K-ME, 400 mm</b>	for Steel Min. order quantity: 10 pieces!	1,25	579801890



## ACCESSORIES SEPARATING TOOLS

Product	Name	Description	Weight (kg)	Part no.
	<b>Diamond cutting wheel Rescue Disc</b>	Blade diameter: 230mm, suitable for all construction materials	0,6	579804617
	<b>Cutting wheel Special diamond Rescue Disc</b>	Diameter 350 mm. Drill 20 mm.	2	579803102
	<b>Saw blade Reciprocating saw, Greenwood</b>	DIN 14555-T3. Tooth pitch 8,5 mm.	0,2	579803109
	<b>Saw blade Reciprocating saw, Wood, and plastics</b>	DIN 14555-T3. Tooth pitch 2,5 mm.	0,2	579803110
	<b>Saw blade Reciprocating saw, Wood with Nails</b>	DIN 14555-T3. Tooth pitch 2,5 mm.	0,1	579803111
	<b>Saw blade Reciprocating saw, Bi-Metal, sheet metal</b>	DIN 14555-T3. Tooth pitch 1,8/2,5 mm.	0,1	579803112
	<b>Safety goggles, direct air ventilation</b>	EN 166. Adjustable headband.	0,65	579802844
	<b>Safety goggles, indirect air ventilation</b>	EN 166. Adjustable headband.	0,1	579802845







## PLASMA CUTTERS

Product	Name	Description	Weight (kg)	Part no.
	<b>Plasma cutter Jäckle 40</b>	DIN 14555-T3. Connection: 400 V/16 A, 1 Phase. Max. Power consumption: 8,0 kVA. Max. Cutting depth: 16 mm. Protection class: IP44.	19,2	579803267
	<b>Plasma cutter Jäckle 65, IP 44</b>	DIN 14555-T3. Connection: 400 V/16 A, 3 Phases. Max. Power consumption: 10,9 kVA. Max. Cutting depth: 22 mm. Protection class: IP44.	26	579803266
	<b>Plasma cutter Hypertherm Power-max 85 FW</b>	DIN 14555-T3, IP44, Connection 50/60 Hz, 400 V/10 A, 3 Phases. Max. Power consumption 20 kVA. Max. Cutting depth 38 mm.	30	579805784







### ACCESSORIES PLASMA CUTTERS

	<b>Welding helmet 3M Speedglas 9100V DIN</b>	For head sizes 50 up to 64	5	579805790
without image	<b>Welding apron</b>		5	579805793
	<b>Welding gloves</b>	Back: Aluminium, palm oil & weather-resistant, heat-resistant	0,5	579805794
	<b>Welding goggles</b>	EN 169. Glass size Ø 50 mm. Safety level 9.	0,1	579802846
	<b>Earplugs 1100 3M™ (VE=200 pairs)</b>	High insulation value SNR=37 dB. 200 pairs in practical dispenser.	0,5	579802887



## PUMPS MAST

Product	Name	Description	Weight (kg)	Part no.
	<b>Submersible pump Mast TP 4/1</b>	DIN 14425, max. Depth 20 m. Liquid density max. 1,1 kg/dm <sup>3</sup> . Connection size G 2.5", Storz B. Free ball passage 8 mm.	21	579800250
	<b>Submersible pump T 6 L</b>	Industry: Wastewater. Max. Depth: 20m. Liquid density max: 1.1 kg/dm <sup>3</sup> . Connection size: G 2", Storz C	21	579800251
	<b>Submersible pump TP 8/1 N</b>	DIN 14425, max. Depth 20 m. Liquid density max. 1,1 kg/dm <sup>3</sup> . Connection size G 2.5", Storz B. Free ball passage 10 mm.	32	579800252
	<b>Submersible pump TP 8/1</b>	DIN 14425, max. Depth 20 m. Liquid density max. 1,1 kg/dm <sup>3</sup> . Connection size G 2.5", Storz B. Free ball passage 10 mm.	39	579800253
	<b>Submersible pump TP 15-1</b>	DIN 14425, max. Depth 20 m. Liquid density max. 1,1 kg/dm <sup>3</sup> . Connection size G 4", Storz A. Free ball passage 15 mm.	45	579800254
	<b>Submersible sewage pump ATP 10 L</b>	Industry: Wastewater max. Depth: 20 m Connection size: G 3"/G 2.5" (suction/pressure) STORZ-Coupling: B	26	579800255
	<b>Submersible sewage pump ATP 10 RL</b>	Industry: Wastewater max. Depth: 20 m Connection size: G 3" / G 2,5" (suction/pressure) STORZ-Coupling: B	27	579800256

## PUMPS MAST

Product	Name	Description	Weight (kg)	Part no.
 	<b>Submersible sewage pump Mast ATP 15 L</b>	Industry: Wastewater. Max. Depth 20 m. Connection size G 3"/G 2.5" (suction/pressure). Storz-Coupling B.	33	579800259
	<b>Submersible sewage pump MAST ATP 15 RL</b>	Industry: Wastewater Max. Depth: 20 m Connection size: G 3" / G 2,5" (suction/pressure) STORZ - Coupling: B	34	579800260
 	<b>All-purpose pump NP 4 B</b>	Industry: Wastewater, Heating oil, Diesel fuel, Power 3kW, Head 30m, Flow rate 500l/min., Connection size: G 2" STORZ - Coupling: C	28	579800267
	<b>All-purpose pump NP 4 D</b>	Industry: Wastewater, Heating oil, Diesel fuel, Power 3,4kW, Head 28m, Flow rate 500l/min., Connection size: G 2" STORZ - Coupling: C	49	579800268
 	<b>All-purpose pump NP 8 B</b>	Industry: Wastewater, Heating oil, Diesel fuel, Power 4,8kW, Head 30m, Flow rate 850l/min., Connection size: G 2,5" STORZ - Coupling: B	43	579800271
	<b>All-purpose pump NP 8 D</b>	Industry: Wastewater, Heating oil, Diesel fuel, Power 3,4kW, Head 28m, Flow rate 850l/min., Connection size: G 2,5" STORZ - Coupling: B	58	579800272
  	<b>All-purpose pump NP 12 B</b>	Industry: Wastewater, Heating oil, Diesel fuel, Power 7,5kW, Head 34m, Flow rate 1200l/min., Connection size: G 2,5" STORZ - Coupling: B	58	579800274
	<b>All-purpose pump NP 12 D</b>	Industry: Wastewater, Heating oil, Diesel fuel, Power 5kW, Head 28m, Flow rate 1200l/min., Connection size: G 2,5" STORZ - Coupling: B	72	579800275
	<b>All-purpose pump Mast NP 12 B</b>	Industry: Wastewater, Heating oil, Diesel fuel, Power 7,5kW, with electric starter, Head 34m, Flow rate 1200l/min., Connection size: G 2,5" STORZ - Coupling: B	58	579803600

## PUMPS MAST





Product	Name	Description	Weight (kg)	Part no.
	<b>Basement drainage pump K 2 F - Flat suction</b>	Contaminated shallow water from a few centimetres, ideal for operation in decon showers, Power 0,7kW, Head 11m, Flow rate 200l/min	7	579800277
	<b>Basement drainage pump K 2</b>	Perfectly suited for draining dirty water in mobile use, Power 0,43kW, Head 7m, Flow rate 250l/min	5	579800278
	<b>Basement drainage pump K 3</b>	Perfectly suited for draining dirty water in mobile use, Power 0,65kW, Head 9m, Flow rate 300l/min	6	579800279
	<b>Basement drainage pump K 5</b>	Perfectly suited for draining dirty water in mobile use, Power 0,81kW, Head 11m, Flow rate 330l/min	7	579800280

### SUBMERSIBLE PUMPS SET MAST





The pump is supplied as a set with all relevant accessories, so your mast pump is ready for immediate use.

	<b>Submersible pumps- Set MAST TP 4/1</b>	Contains TP4/1, Personal protection device, Cable holder with related combination wrench, 2x Coupling wrench ABC, Pressure hose B 20m, Outlet pipe B, Hose kink protection, Rope holder. Cable with carabiner, Carrying case	37	579800294
	<b>Submersible pumps- Set TP 8/1</b>	Contains TP8/1, 2xCouplingsschlüssel ABC, Pressure hose B 20m, Outlet pipe B, Hose kink protection, Rope holder. Cable with carabiner, Carrying case	56	579800295
	<b>Submersible pumps- Set TP 15/1</b>	Contains TP15/1, 2xCouplingsschlüssel ABC, Pressure hose A 15m, Outlet pipe B, Distributor A-BB, Rope holder. Cable with carabiner, Carrying case	63	579800296

## ACCESSORIES PUMPS MAST

Product	Name	Description	Weight (kg)	Part no.
	<b>Outlet pipe MAST</b>	with B fixed coupling	2,4	579805682
	<b>Carrying case MAST</b>	For transporting pump equipment, stackable	9,4	579805683
	<b>Pressure hose</b>	Coupling: Storz B Length 3000 mm	3	579805923
	<b>Hose kink protection MAST B/C</b>	for C and B Hoses, prevents kinks and damages due to sharp edges and corners.	0,8	579806135
	<b>Cable holder Mast</b>	for TP 4-1 and T 6 L	1	579806177

## VACUUM CLEANERS

Product	Name	Description	Weight (kg)	Part no.
	<b>Fire brigade Vacuum cleaner HYDRA BOY</b>	Tank volume:45l, Suction passage Ø 28mm, Suction capacity 8.000 l/h Performance suction turbine 1200 Watt, Performance sewage pump 900 Watt, incl. suction and drain hoses, suction hoses with several nozzles	18	579809360
	<b>Fire brigade Vacuum cleaner HYDRA</b>	Tank volume:70l, Suction passage Ø 40mm, Suction capacity 20.000 l/h Performance suction turbine 1200 Watt, Performance sewage pump 1500 Watt, incl. suction and drain hoses, suction hoses with several nozzles	33	579808586
	<b>Pre-separator ULTRA</b>	90l Tank capacity, Connection hose Storz C 1m, Filter sieve: Aluminium, 22mm hole diameter, Sponge filter: PPI 10T/PUR-Ether	12,5	579817989
	<b>Chassis for pre-separator ULTRA</b>	max. load capacity: 250kg	7,5	579817990
	<b>Rössle Universal squeegee</b>	For the removal of a wide variety of soiling in solid and liquid form. Nylon broom with plastic slider.		579817988









**EXPERTS IN  
HANDLING WATER**





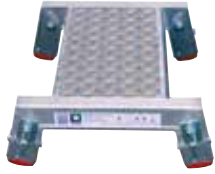

**rössle**

Vacuum cleaners for fire departments







## LADDERS MUNK RETTUNGSTECHNIK

Product	Name	Description	Weight (kg)	Part no.
	<b>Scaling ladder - Lower section, edged - MUNK Rettungstechnik</b>	EN 1147, Scaling ladder part A, 2,7 m, 9 Rungs.	10	579801657
	<b>Scaling ladder - Lower section, Wood</b>	EN 1147, Scaling ladder part A, 9 Rungs	14	579801659
	<b>Scaling ladder - Upper section, edged - MUNK Rettungstechnik</b>	EN 1147, Scaling ladder part B, 7 Rungs.	9,8	579801658
	<b>Scaling ladder - Upper section, Wood</b>	EN 1147, Scaling ladder part B, 7 Rungs	14	579801660
	<b>Scaling ladder - push-fit section - LM, T3, 2 rungs MUNK Rettungstechnik</b>	2 Rungs, in addition to Scaling ladder parts B.	4	579801669
	<b>Scaling ladder - push-fit section - H, T3, 3 rungs MUNK Rettungstechnik</b>	3 Rungs, in addition to Scaling ladder parts B.	5	579801670
	<b>Scaling ladder - Connecting section MUNK Rettungstechnik</b>	DIN EN 1147. To combine 2 scaling ladder parts into one scaling ladder.	8	579801671
	<b>Push-up extension ladder 3-section, edged - MUNK Rettungstechnik</b>	EN 1147. Rope brake and swivel hook. Length extended 14 m. Length retracted 5,5 m.	71	579801673





## LADDERS MUNK RETTUNGSTECHNIK

Product	Name	Description	Weight (kg)	Part no.
	<b>Multi-function ladder LM Fire brigade MUNK Rettungstechnik</b>	<p>For universal applications. Consisting of 3 ladder sections: 2 sections connected through hinge joints, 3rd section as scaling ladder. 2 Multi-function ladders combined into one through spring bolts, to match any deployment situation. Permissible load in any extension configuration: 2 people. With extension also suitable in narrow spaces, e.g., in shafts or ice rescues.</p> <p>EN 1147, 3 ladder parts, rung height 280 mm, Ladder length folded 2,3 m.</p>	23,5	579801661
<b>ACCESSORIES MULTI-FUNCTION LADDER MUNK RETTUNGSTECHNIK</b>				
	<b>Base widener for Multi-function ladder</b>	<p>Base widener secures multi-function ladder to climb without further safety devices. (on stable ground)</p>	2	579801662
	<b>Base widener for Multi-function ladder, adjustable</b>	<p>Adjustment mechanism to adapt height up to 220mm.</p>	8	579801663
	<b>Side-rail extension for Multi-function ladder</b>	<p>Balance surface irregularities of up to approx. 300mm.</p>	2	579801664
	<b>Multi-function ladder - Connecting section MUNK Rettungstechnik</b>	<p>For creating a double-sided ladder, bridging step, tripod, or hose conveyance</p>	14	579801665
	<b>Head bracket for Multi-function ladder</b>	<p>For placing over the two top rungs. Descender hooked into head bracket for shaft rescues.</p>	1	579801666



## LADDERS MUNK RETTUNGSTECHNIK

Product	Name	Description	Weight (kg)	Part no.
<b>ACCESSORIES MULTI-FUNCTION LADDER MUNK RETTUNGSTECHNIK (CONTINUED)</b>				
	<b>Scaffolding bracket for Multi-function ladder</b>	For setting up a ladder platform, consists of 2 multi-function ladders and one ladder platform. Quantity 2 Piece	6	579801667
	<b>Rescue and working platform for Multi-function ladder</b>	With 2 Multi-function ladders can be turned into platform for rescuing injured persons from trucks, buses, and trains	53	579801668
	<b>Hook ladder, light metal</b>	10 climbing rungs welded with side-rails, 3 hook rungs and 1 deck rung with Folding hook made of galvanised steel secured with locking pin.	11,5	579801677
	<b>Hook ladder, Wood</b>	Folding hook made of galvanized steel, 10 climbing rungs welded with side-rails, 3 hook rungs and 1 deck rung with Folding hook made of galvanised steel secured with locking pin.	12	579801676
	<b>Folding ladder, Wood</b>	EN 1147. 9 Rungs.	11,5	579801678
	<b>Telescopic ladder MUNK Rettungstechnik</b>	DIN EN 1147:2010-10, Capacity 250 kg, certified rescue ladder for 2 people, Length extended: 3,5 m	15	579808115
	<b>Telescopic ladder MUNK Rettungstechnik</b>	DIN EN 1147:2010-10, Capacity 250 kg, certified rescue ladder for 2 people, Length extended: 4,4 m		579808116
	<b>Lifting harness</b>	3m long, made from ash with fitting made of galvanised steel and carrying handle.	11	579801680

## RESCUE AND WORKING PLATFORMS

Product	Name	Description	Weight (kg)	Part no.
	<b>Rescue and working platform MUNK Rettungstechnik, 83 x 172 mm</b>	For rescuing accident victims from a driver's cab, for example, and as a work platform. Sturdy structure made of aluminium, Platform with non-slip coating (R 13). Non-slip and ribbed rungs. Adjustable platform height using ergonomically shaped handles. Sturdy locking bolts for secure locking in a grid of 265 mm. Folding access ladders on both sides with self-locking steel hinges. All four side-rails with side-rail extensions as standard (height compensation of max. 250 mm, locking in 30 mm increments). Folding railing can be used on the left or right. Long luminescent markings for better visibility in the dark.  DIN 14830, Height mm adjustable 880-1400, Capacity 500 kg, Transport dimensions 1790x1050x280 mm, adjustable Side-rail extension to balance surface irregularities	51 kg	579801686
	<b>Rescue and working platform Lukas LRP 6</b>	DIN 14830, Height adjustable from 800 - 1400 mm, Side-rail extension to balance surface irregularities, Platform 1770x850 mm, max. Load capacity 500 kg, Transport dimensions 1980x1080x220 mm	47	579801405
	<b>Rescue and working platform MUNK Rettungstechnik 750 x 1860 mm, Height 0,97 m</b>	Large-scale platform with anti-slip surface, complete with 4 lugs. Load capacity max. 500 kg.	30	579801683
<b>ACCESSORIES RESCUE AND WORKING PLATFORM MUNK RETTUNGSTECHNIK</b>				
	<b>Rail for Rescue and working platform 75x186mm, pluggable</b>	Right or left-sided. Lugs made of galvanised steel. Quantity: 1 Rail, 4 slit pockets, 4 safety plugs.	2,5	579801684

## RESCUE AND WORKING PLATFORMS







Product	Name	Description	Weight (kg)	Part no.
<b>ACCESSORIES RESCUE AND WORKING PLATFORM MUNK RETTUNGSTECHNIK (CONTINUED)</b>				
	<b>Side-rail extension height adjustable for Rescue and working platform 75x186mm</b>	To balance surface irregularities. Easy mounting at lower rail end. Adjustment range max. 375 mm.	1,5	579801685
	<b>Rail carriage for Rescue and working platform 83 x 172 mm</b>	Track width 1,435 m, permissible Load capacity max. 500 kg.	30,5	579801687







In critical situations, every second holds immense value, underscoring the significance of functionality and reliability. With quality being a core tenet of ours, you can place your trust in our ladders, mission-specific rescue platforms, toolboxes and wide range of mobile container solutions.

[www.munk-rettungstechnik.de/en](http://www.munk-rettungstechnik.de/en)

## TOOL SET FALL ARREST/PULLEY

Product	Name	Description	Weight (kg)	Part no.
	<b>Equipment set Edelrid Fall arrest DIN 14800-17</b>	<p>Complete equipment set, assembled according to DIN 1488-17, and stowed in a useful transport bag. For securing emergency workers in areas where there is a risk of falling. The set contains all the components required by DIN for efficient self-securing. Set "Edelrid" (Part no.: 579816678) delivered with all products produced by Edelrid (Specialist for Mountaineering and Industrial safety).</p> <p>Alternatively, Set "Dönges" (Part no.: 579817291) includes only Edelrid products except Seal-D travel bag and Dönges HMS Carabiners.</p> <p>Quantity:            1 Piece Dynamic core rope Dynamite 11.0 mm, 60 m            1 Piece Harness Core Plus Triple Lock            1 Piece Fall arrester with 12 mm Core-mantle rope            15 Piece Ribbon sling 25 mm, 80 cm circumference            2 Piece Ribbon sling 25 mm, 150 cm circumference            2 Piece HMS Carabiner Magnum Triple            17 Piece Carabiner D-Classic 3000 Screw 2 Pairs            Gloves »Fitter Maxx«, Gr. 10            1 Piece PSA Rucksack 45 L, red</p>	14,4	579816678
	<b>Tool set Dönges Fall arrest DIN 14800-17</b>		14,4	579817291
	<b>Full body harness Flex Pro Plus</b>	Comfortable, practical harness for working in fall risk areas. Equipped with a fall indicator and wide back padding, it is pleasant to wear and adapts perfectly to any body shape.	2,1	579809174
	<b>Full body harness Flex Pro Plus</b>		2,1	579809175
	<b>Full body harness Flex Pro Plus</b>		2,1	579809176
	<b>Core-mantle rope Dynamite Ø11 mm II, 60 m</b>	EN 892, Single rope, Impact force [kN]: 8,8, Dynamic elongation [%]: 31	5,1	579816586
	<b>Ribbon sling X-Tube LOOP</b>	Sewn ribbon sling with a sensational 30 kN breaking strength	0,4	579816681
	<b>Ribbon sling X-Tube LOOP</b>	Sewn ribbon sling with a sensational 30 kN breaking strength	0,75	579816682

## TOOL SET FALL ARREST/PULLEY

Product	Name	Description	Weight (kg)	Part no.
	<b>Locking carabiner D-Classic 3000 Triple II</b>		0,1	579816688
	<b>Pure Screw Edelrid Carabiner</b>		0,1	579816634
	<b>Fall arrester Ombilix Adjust</b>	Adjustable lanyard with a 12 mm core mantle rope for work positioning at height (in accordance with EN 358). The length of the OMBILIX ADJUST can be quickly and easily adjusted using a rope clamp.	0,1	579816061
	<b>Energy absorber Shock stop Giant Twister Triple</b>	I-lanyard with elasticated arm and DSG 2500 GIANT palm carabiner. The carabiner's simple handling and large gate opening make the set particularly ideal for uses in the field of scaffolding. The integrated shock absorber enables a high maximum load of 140 kg. The individual carabiner and the SHOCKSTOP-I 140 GIANT as a system have been edge tested. Minimum breaking strength [kN]: 15, Large aluminium carabiner with an opening width of 64 mm. High maximum load capacity (140 kg) and ultimate load of 25 kN, EN 362, EN 354, EN 355	1,3	579816687
	<b>Backpack Edelrid PSA 45I</b>	Perfectly suitable to store and transport PPE equipment.	0,7	579817146



**MAGIRUS STRETCHER RESCUE LADDER**  
Certified according to EN 795  
Max. payload: 500 kg, Part no. 579806461

**THE SET CONSISTS OF THE FOLLOWING INDIVIDUAL PARTS:**

- 2 intermediate pieces 3 m
- 1 intermediate piece 6 m
- 1 suspension (horizontal and vertical)
- 1 ladder tip adapter
- 1 crane hook adapter
- 1 rescue triangle for patient safety
- 1 transportation backpack
- 1 user manual

# MINIMISE OPERATIONAL STRESS, MAXIMISE SUCCESS.

**Narrow shafts, excavations, steep terrain: often, rescue operations can be significantly simplified by using a turntable ladder. The Magirus Connection Telephone Rescue allows for such rescues to be carried out safely and quickly. The Magirus Connection Telephone Rescue represents a self-contained redundant safety system and is certified according to EN 795. The maximum load capacity is 500 kg, and the rescue length adjustable in increments of 3, 6, 9, and 12 meters.**

The Magirus Connection Set for patient rescue can be easily attached to the ladder tip, the Magirus Safety Peak, and the basket stretcher without any further preparation. If necessary, accompanied rescue is also possible.

The set includes a crane adapter for rescue with a crane, such as a building, hall, or fire brigade crane, which is also suitable for double hooking. The individual components are connected by car-

abiners with automatic locking mechanism and single-handed operation. The individual parts are permanently connected and can only be separated with the help of tools. The Connection Set for patient rescue can be used with a rescue loop as well as for vertical hanging stretcher rescue. The suspension can also be used separately, for example, with the Magirus Tool set for abseiling and ascending.

The entire set must be inspected once a year by a qualified person for personal fall protection equipment.

Part no. 579806461



Adapter crane hook, also suitable for double hooking.









Adapter ladder tip: Loads of up to 500 kg can be moved quickly and easily.





The self-redundant harness with adjustable patient safety allows for rescue with a vertically suspended stretcher.





## TOOL SET FALL ARREST/PULLEY

Product	Name	Description	Weight (kg)	Part no.
	<b>Adapter ladder Magirus</b>	Single part of the Magirus Connector set Stretcher rescue. Moves up to 500 kg fast and simple.	1,2	579806464
	<b>Adapter stretcher Magirus</b>	Single part of the Magirus Connector set Stretcher rescue.	1,3	579806465
	<b>Adapter crane Magirus</b>	Single part of the Magirus Connector set Stretcher rescue.	0,8	579806466
without image	<b>Extension 3 m Magirus</b>	Single part of the Magirus Connector set Stretcher rescue.	0,5	579806462
	<b>Extension 6 m Magirus</b>	Single part of the Magirus Connector set Stretcher rescue.	0,7	579806463
	<b>Tool set pulley Type 4:1, Bornack</b>	Content according DIN 14800-16. Lifting height 30 m. Rope length 150 m. Max. Workload 400 kg.	15,5	579801243
	<b>Tool set pulley Type ROLLGLISS 3:1</b>	Content according DIN 14800-16. Lifting height 50 m. Rope length 120 m, Working length 30 m Max. Workload 250 kg.	13,3	579801245
	<b>Securing set, Bornack</b>	Content according DIN 14800-17.	12	579801249





## TOOL SET FALL ARREST/PULLEY

Product	Name	Description	Weight (kg)	Part no.
	<b>Securing set 1 Skylotec Set 202</b>	This safety set consists of the seat belt CS 8, which is suitable for many different applications due to its back, chest, holding and seat belt eyelets. Its leg and back pads and its many adjustment possibilities make it a comfortable everyday harness. The LORY X SET is used for workplace positioning. The X-TREM DYNAMIK 11.0 in 60 metres length is a dynamic rope which convinces by its robustness and abrasion resistance. 17 LOOP 26kN webbing slings (15x 80 cm / 2x 150cm), 17 OVALSTEEL-SC carabiners and one passO-Tri carabiner are included and serve to attach the rope. Two pairs of GRIP gloves complete the set and protect the wearer's fingers. A DRYBAG is included in the set so that everything can be stowed away safely.	13,1	579805983
	<b>Securing set 3 Skylotec Set 202-PRO</b>	This securing set consists of the seat belt IGNITE ARGON, which is suitable for many different applications due to its back, chest, support, and seat belt eyelets. Its breathable and anatomically shaped leg and back pads and its many adjustment options make it a comfortable everyday harness. The LORY X SET is used for workplace positioning. The X-TREM DYNAMIK 11.0 in 60 meters length is a dynamic rope which convinces by its robustness and abrasion resistance. 17 LOOP 26 kN webbing slings (15x 80 cm / 2x 150cm), 17 OVALSTEEL-SC carabiners and one passO-Tri carabiner are included and serve to attach the rope. Two pairs of SKYGRIP FullFinger gloves complete the set and protect the wearer's fingers. A DRYBAG is included in the set so that everything can be stowed away safely.	14,7	579817318
	<b>Securing set fire brigade Gordon Skylotec Set-112</b>	Set of equipment, which can be used for rescuing people from heights and depths up to 30 meters, in accordance with DIN 14800-16. The GORDON RESCUE fall arrest device works in both directions by self-blocking using centrifugal force. It can be released again by deliberately manipulating the rope. It is quick and easy to prepare the pulley system for use. The LORY safety device is placed on the load arm and a sling attached to the device using the DOUBLE TRI carabiner. This creates an anchor point, e.g., for attachment to a vehicle. The load or person to be moved (with a rescue harness) is attached to the carabiner under the GORDON pulley system and can be then be let down or lifted. Where necessary, the hand rope clamp can be used on the load arm to improve the ergonomics and application of force during the lifting process. All GORDON PULLEY SYSTEMS can be loaded with up to 260 kg.	13,7	579808493









## TOOL SET FALL ARREST/PULLEY

Product	Name	Description	Weight (kg)	Part no.
	<b>Rope X-TREM DYNA-MIK Ø 11 mm</b>	EN 892, Suitable for edges, Static elongation: 5,7%, Temperature range: -35 °C - 55 °C	6	579817319
without image	<b>Ribbon sling LOOP</b>	EN 354:2010, EN 566:2006, EN 795-B:2012, Ultimate load: 26 kN, Diameter: 25 mm, Max. Number of persons: 1, Temperature range: -35 °C - 45 °C	0,1	579805168
	<b>Ribbon sling LOOP</b>	EN 354:2010, EN 566:2006, EN 795-B:2012, Ultimate load: 26 kN, Diameter: 25 mm, Max. Number of persons: 1, Temperature range: -35 °C - 45 °C	0,14	579805169
	<b>Gloves SKYG- RIP FullFinger size L</b>	EN 388:2016, EN 420:2003+A1:2009, tear- and scrub-resistant. Light gloves for belaying or via ferrata climbing. Protects the hands from the frictional heat generated while belaying or rappelling, as well as from minor injuries from contact with the rock or sharp protruding strands from the steel cable while via ferrata climbing. <ul style="list-style-type: none"> <li>• Palm made of robust synthetic leather for optimal grip</li> <li>• Velcro on the wrist for good fit</li> <li>• Loop on the wrist for attaching to harness</li> </ul>	0,2	579817320
	<b>Gloves SKYG- RIP FullFinger size XL</b>		0,2	579817323
	<b>Rescue sheet RESC B</b>	EN 1498-B, Max. Number of persons: 1, Temperature range: -35 °C - 45 °C, permissible weight: 140 kg	0,7	579805177
	<b>Full body harness CS 8</b>	EN 358:1999, EN 361:2002, EN 813Max. hip size: 850-1500mm, Temperature range: -35 °C - 45 °C, Max. Number of persons: 1, Dorsal steel attachment point, Side steel attachment point, Sit harness steel attachment point, Sternal polyester attachment point, permissible weight: 140kg	1,7	579807308
	<b>Fall arrester LORY X</b>	EN 358:2018, EN 795-B:2012, permissible weight: 150kg, Temperature range: 60 °C - -20 °C, allows the length of a rope to be set, even under load, integrated anti-panic function	1,2	579817331





## TOOL SET FALL ARREST/PULLEY

Product	Name	Description	Weight (kg)	Part no.
	<b>Steel carabiner LARGE STEEL TG</b>	EN 362-M:2004, automatic triplex twist-lock gate, opening width: 25mm	0,2	579817339
	<b>Steel carabiner XL-D SG</b>	EN 12275-B:2013, EN 362-B:2004, with large capacity base and screw gate, opening width: 29mm	0,1	579817342
	<b>Rucksack straps DRY-BAG</b>	Content: 59 L, waterproof	0,9	579805178
	<b>Rucksack straps DRY-BAG</b>		0,9	579817350



## ROPES/ ROPE BAGS

Product	Name	Description	Weight (kg)	Part no.
	<b>Fire brigade rope Rische FL 30-K</b>	DIN 14920. Length 30 m. With thimble A10 and carabiner hook or with Eye splice	2,3	579802074
	<b>Fire brigade rope Rische FL 30-H</b>	DIN 14920. Length 30 m. With wooden lever or with Eye splice		579802073
	<b>Multi-purpose rope Rische A20-K</b>	DIN 14920. Length 20 m. With thimble A10 and carabiner hook or with Eye splice	1,9	579802076
	<b>Multi-purpose rope Rische A20-H</b>	DIN 14920. Length 20 m. With wooden lever or with Eye splice	0,9	579802077
	<b>Multi-purpose rope bag ultraMedic, brown</b>	DIN 14921. With Flap and Buckle.	0,2	579801741
	<b>Multi-purpose rope bag ultraMedic, bright orange</b>	DIN 14921. Made from Cotton, with Flap and Buckle.	0,3	579801742
	<b>Pulling rope for rope bag, 100 cm</b>	With 2 Carabiners.	0,1	579801743
	<b>Fire brigade multi-purpose bag ultra- Medic</b>	To combine with carrying strap (Part no. 579805936) according to DIN 14922:2011:04, with Buckle	0,2	579805935
	<b>Carrying strap for fire brigade multi-purpose bag ultra medic</b>	Fire brigade multi-purpose bag combined with carrying strap conforms with DIN 14922:2011	0,1	579805936
	<b>Rope carrying bag ultra-Medic, black</b>	With Tie string.	0,2	579801734

## ROPES/ ROPE BAGS

Product	Name	Description	Weight (kg)	Part no.
	<b>Rope bag Kombi tee-uu</b>	with several pockets and loops to accommodate rope, holster etc. Print „Fire brigade“, incl. Carrying strap	0,35	579804764
	<b>Rope bag Dorsten</b>	with PA fixing and additional pockets, for 30 m Fire brigade rope or one 100 m guide rope	0,37	579804642
	<b>Dönges Rope bag PA</b>	suitable for ropes up to 30 meter, with leakage protection can be attached to almost all respiratory protective devices without any problems.	0,4	579808111
	<b>Rope holder</b>	DIN 14828-H, Ø 10 mm, 1,6 m, spiral plaited. With wooden lever or with Eye splice	0,2	579802911
	<b>Rope holder</b>	with Carabiner	0,2	579804472

## BASKET STRETCHER ULTRAMEDIC









Product	Name	Description	Weight (kg)	Part no.
	<b>Basket stretcher ultra-Medic ultraBASKET</b>	Incl. Straps, Mattress, and Footrest. Capacity 315 kg.	12,2	579801770
	<b>Basket stretcher ultra-Medic ultraBASKET TWIN</b>	Separable, incl. Straps, Mattress and Footrest, Capacity 315 kg  All basket stretchers: - are made of high quality, impact resistant and robust ASA/ABS plastic with continuous tubular aluminium frame - are corrosion resistant, resistant to chemicals and temperature extremes - have a 40 mm thick mattress, which is easy to clean and disinfect, because of the Velcro attachment quickly and easily removed for cleaning or replacement - they also have a newly developed adjustable footrest with Velcro for fixing the feet, all around lateral grip recesses and a revolving nylon rope on which the tethers may be attached - mixed with 3 safety belts with metal pushbutton buckle and a practical storage bag (for belts) delivered	12	579801771
	<b>Basket stretcher ultra-Medic ultraBASKET XXL</b>	Incl. Straps, Mattress, and Footrest. Capacity 400 kg.  This basket stretcher was specifically designed to withstand extreme conditions. The special advantage of this voluminous rescue equipment is its divisibility for space-saving storage and easy transport to the patient. The construction is based on the tried and tested elements of ultraBASKET STRETCHER TWIN.	12,2	579808573





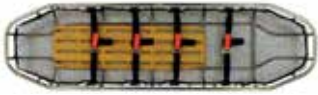

## BASKET STRETCHER ULTRAMEDIC

Product	Name	Description	Weight (kg)	Part no.
<b>ACCESSORIES BASKET STRETCHER ULTRAMEDIC</b>				
	<b>Transport gear ultra-Medic ultra- BRIDLES for Basket stretcher</b>	Transport gear in black and yellow for basket stretcher with 4 steel carabiners, length adjustable	2	579801772
	<b>Carrying bag for Basket stretcher 1 piece, ultraMedic</b>	With Handle and fixing lugs	3	579801773
	<b>Carrying bag for Basket stretcher 2 pieces - ultraMedic</b>	With Handle and Fixing lugs	1,9	579801774
	<b>Protection cover ultraTHERM</b>	Reusable cover for optimal thermal insulation in an emergency.	1,9	579817365
	<b>Protection cover ultraTHERM G</b>	Reusable cover for optimal thermal insulation in an emergency. With slits.	1,9	579817374
	<b>Flotation collar ultra-FLOATING</b>	Flotation collar for Basket stretcher	4	579801775
	<b>Splash guard for Basket stretcher ultraSPLASH GUARD</b>		10	579808837
	<b>Carriage ultraGEAR</b>	Optional carriage for mounting on the 1- and 2-piece basket stretcher.	3,9	579817417

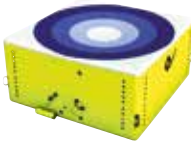

## BASKET STRETCHER FERNO

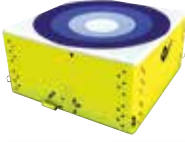
Product	Name	Description	Weight (kg)	Part no.
	<b>Basket stretcher Ferno 71</b>	Capacity 272 kg. Incl. 4 Patient straps and Footrest.	13	579802532
	<b>Basket stretcher Ferno 71 S</b>	Separable, Capacity 272 kg. Incl. 4 Patient straps and Footrest.	10	579802533
	<b>Bridle Ferno for Basket stretcher 71/71 S</b>	Highly robust version with 4 large, self-locking carabiners.	2,5	579802534
	<b>Safety &amp; carrying bag for Ferno Basket stretcher</b>	for rigid Basket stretcher (except 2070-32)	1,5	579817096
	<b>Safety &amp; carrying bag for Ferno</b>	for separatable Basket stretcher	1,5	579817097
	<b>Basket stretcher 2070</b>	Capacity max. 1100 kg	14	579802538
	<b>Basket stretcher 2070 S</b>	Capacity max. 1100 kg, separable	16,3	579802540
	<b>Basket stretcher 2070-32</b>	Capacity: 1.134 kg, Heavy load model, slightly bevelled edges.	19,2	579802542
	<b>Bridle Ferno for series 2070 up to 2074</b>	With four Carabiner hooks. With sewed-on loops to secure carabiners.	2,5	579802546









## JUMPING CUSHIONS VETTER

Product	Name	Description	Weight (kg)	Part no.
	<b>Safety cushion SP 16 Vetter, blue circle</b>	For fires in buildings with up to 16 m, Measurements 350 x 350 x 170 cm (LxWxH). Working pressure 0,37 bar, Test pressure 0,48 bar, Air requirement 1.374 l.	49	579801149
	<b>Safety cushion SP 16 Vetter, black cross</b>	For fires in buildings with up to 16 m, Measurements 350 x 350 x 170 cm (LxWxH). Working pressure 0,37 bar, Test pressure 0,48 bar, Air requirement 1.374 Litre.	49	579801150
	<b>Safety cushion Set SP 25, blue circle</b>	For fires in buildings with up to 25 m, Measurements 460 x 460 x 240 cm (LxWxH). Working pressure 0,48 bar, Test pressure 0,62 bar, Air requirement 2.006 l.	75	579801155
	<b>Safety cushion Set SP 25, black cross</b>	For fires in buildings with up to 25 m, Measurements: 460 x 460 x 240 cm (LxWxH). Working pressure 0,48 bar, Test pressure 0,62 bar, Air requirement 2.006 Litre.	78	579801156





### ACCESSORIES JUMPING CUSHIONS VETTER

	<b>Compressed-air cylinder Vetter 6 l/300 bar</b>	UNFILLED. For Safety cushion SP 16, Steel, 5/8" IG, 1.800 l	8,2	579801152
	<b>Compressed-air cylinder Vetter 9 l/300 bar</b>	UNFILLED. For Safety cushion SP 25, Composite, 5/8" IG, 2.700 l	5,3	579801157
	<b>Valve protection Vetter for Compressed-air cylinder 6l/300 bar</b>	For Compressed-air cylinder with Neck diameter 27-30 mm.	0,6	579801153
	<b>Test gauge Vetter for Safety cushion SP 16</b>	To test Safety cushion.	0,3	579801151
	<b>Vacuum adaptor for Rescue path and Safety cushion</b>	Quick coupling to connect to air supply.	0,3	579801154

## SLINGS/RESCUE BLANKETS

Product	Name	Description	Weight (kg)	Part no.
	<b>Rescue blanket ultraSAVER, ultraMedic</b>	DIN EN 1865, Capacity 250 kg.	0,9	579801744
	<b>Rescue blanket ultraSAVER FIX, with foot muff</b>	DIN EN 1865, Capacity: 250 kg.	0,8	579801745
	<b>Storage bag ultraSAC for Rescue blanket, ultraMedic</b>	with straps, red	0,1	579801746
	<b>Rescue blanket ultraSAVER SPECIAL XXL</b>	DIN EN 1865. Rescue blanket with special coating and Foot muff. Capacity 400 kg.	4,8	579801747
	<b>Storage bag ultraSAC XXL for Rescue blanket</b>		0,1	579801748
	<b>Rescue blanket incl. Carrying bag</b>	EN 1865. Loading standard DIN 14530 and DIN 14555. Capacity up to 150 kg. Water-proof and impermeable.	0,7	579802939
without image	<b>Rescue blanket GERET</b>	DIN EN 1865, max. Capacity: 200 kg	0,7	579807547
	<b>Rescue blanket GERET-WIDE</b>	incl. Bag, max. Capacity: 500 kg	1,6	579806618
	<b>Disposable rescue blanket</b>	EN 1865. Double stitched edges. Capacity 150 kg.	0,62	579802941
	<b>Disposable blanket, 6 layers</b>	Outside: fleece, sewn. Inside: Cellulose fabric in layers. Version: Summer (6 layers). Packed individually.	0,3	579802942

## SLINGS/RESCUE BLANKETS

Product	Name	Description	Weight (kg)	Part no.
	<b>Disposable blanket, 12 layers</b>	Outside: fleece, sewn. Inside: Cellulose fabric in layers. Version: Winter (12 layers). Packed individually.	0,3	579804082
	<b>Rescue blanket, gold/silver aluminium-vaporized</b>	Also suitable for thermal protection.	0,1	579802943
	<b>Woollen blanket ultra-BLANKET</b>	Woollen blanket Camel made from 100% polyester	0,8	579801753
	<b>Bag for woollen blanket ultraBLANKET</b>	Packaging and Protection cover	0,1	579801754

## STRETCHERS

Product	Name	Description	Weight (kg)	Part no.
	<b>Stretcher N</b>	DIN 13024. 4 Slide feet, Lockable steel hinges. Retractable handles. Two adjustable straps with quick closure for secure fixation of the injured.	8	579802945
	<b>Stretcher K</b>	DIN 13024. 4 Slide feet, 2 x foldable, Lockable steel hinges. Retractable Handles. Two adjustable straps with quick closure for secure fixation of the injured.	9,7	579802944
	<b>Carrying bag for Stretcher N</b>	Carrying and Protection bag.	0,8	579802947
	<b>Carrying bag for Stretcher K</b>	Carrying and Protection bag.	0,5	579802946
	<b>Stretcher ultra-STRETCHER N</b>	DIN 13024 N, 1x foldable, 4 Slide feet	7,7	579801750
	<b>Stretcher ultra-STRETCHER N</b>	DIN 13024 N, 1 x foldable longitudinal, with 4 slide feet	8,6	579804757
	<b>Stretcher ultra-STRETCHER N</b>	DIN 13024 N, 1 x foldable longitudinal, with 2 slide feet and 2 casters.	7,7	579805143
	<b>Stretcher ultra-STRETCHER, K</b>	DIN 13024 K, 2x foldable, 4 Slide feet, grey	7,5	579801749
	<b>Stretcher ultra-STRETCHER K</b>	DIN 13024 K, 2x f foldable longitudinal, with 4 slide feet		579804571
	<b>Stretcher ultra-STRETCHER K</b>	DIN 13024 K, 2x foldable longitudinal, with 2 slide feet and 2 casters.		579805446

## SCOOP STRETCHERS & VACUUM MATTRESSES

Product	Name	Description	Weight (kg)	Part no.
	<b>Scoop stretcher ultra-SCOOP with straps</b>	Scoop stretcher incl. 3 straps, Capacity up to 180 kg	8,3	579801776
	<b>Scoop stretcher ultra-SCOOP X-RAY with straps</b>	Scoop stretcher made from high-quality Plastic, radio translucent, incl. 3 straps	9,5	579801777
	<b>Storage bag ultraSPINE BAG</b>		1,4	579801756
	<b>Vacuum mattress X-BOON TWO</b>	More than 140 vacuum chambers, asymmetrical pattern, reinforced in critical spots, easy to clean and disinfect	6,3	579817422
	<b>Storage &amp; Carrying bag for X-BOON</b>	for X-BOON Vacuum mattress	1,2	579817423
	<b>Backpack bag ultraROLL BAG</b>	for ROLL STRETCHER	1	579817424
	<b>Vacuum hand pump ultraVACPUMP I</b>	for Vacuum mattress	1	579817425
	<b>Vacuum mattress, EN 1865</b>	EN 1865. Rotary valve. Eight handles alongside. Two-coloured version.	7	579802982

## SPINE BOARDS

Product	Name	Description	Weight (kg)	Part no.
	<b>Spine board ultra- Medic S-BOON</b>	DIN 1865, Special stretcher for Spinal Injuries, incl. 3 straps for securing patients. Certified capacity up to 150kg according DIN 1865. During DIN assessment, S-Boon Spine board exceeded required weight of 250kg with permanent load capacity of 500kg.	8	579804559

### ACCESSORIES SPINE BOARD ULTRAMEDIC



	<b>Head restraint set ultraHEAD Lock I - ultraMedic</b>	For securing the head on the scoop stretcher, spine board or similar.	1	579801759
	<b>Head restraint set ultraHEAD Lock II</b>	For securing the head on the spine board, X-ray permeable, suitable for MRI and CT.	1	579807252
	<b>Safety harness ultraS-TRAPS for spine board</b>	Safety harness for ultraSPINE board with Velcro.	0,4	579801757
	<b>Replacement set for Spine board ultraBELT</b>	3 Straps + Bag with metal quick-lock buckle	0,7	579817426
	<b>Replacement strap ultraBELT</b>	for Basket stretcher etc. with quick-lock buckle	0,2	579809634









## SPINE BOARDS

Product	Name	Description	Weight (kg)	Part no.
	<b>Spencer Spine board B-Bak with Pins</b>	Temperature range: -20 up to +60 °C, durable up to 180 kg, 14 circulating handle bar, speed clip bars, radio translucent	9,7	579809572





### ACCESSORIES SPINE BOARD SPENCER SPINEBOARD

	<b>Head restraint set Spencer Super Blue</b>	Description: Quantity: 1x Base plate, 2x Head rest, 2x Fixation strap with pad	1	579806173
	<b>Spencer Strap system Rock Straps universal</b>	For complete immobilization of patients onto spine boards.	0,5	579806132

## FIRST-AID BOXES & BACKPACKS

Product	Name	Description	Weight (kg)	Part no.
	<b>Vehicle first-aid box ultraTRAFFIC, filled according DIN 13164</b>		0,7	579801769
	<b>First-aid kit K</b>	First-aid kit according DIN 14142-K in Dönges Fire-box® according DIN 14880-4-LM with Sections and Marking „First-aid kit K DIN 14142“.	3,9	579804000
	<b>Backpack First Responder, filled according DIN 13155, red</b>	Front pocket can be widened through addtl. Zipper, ideal to contain all common AEDs.	5,5	579801762
	<b>Backpack FIRE &amp; RESCUE, filled according DIN 14142, red</b>	Contains 5 colour-sorted ultraMODUL bags, 1 x ultraOXYTAINER	5,5	579801763
	<b>Backpack ultraRESCUE LITE FIRE</b>	Light and compact rescue backpack with firefighting equipment according DIN 14142	4,5	579817427
	<b>Backpack RESCUE I</b>	5 colour-sorted ultraMODUL bags, freely positioned inside of backpack, front bag with space for AED.	4,5	579805798





## FIRST-AID BOXES & BACKPACKS

Product	Name	Description	Weight (kg)	Part no.
	<b>Backpack RESCUE II</b>	Fitted with 5× ultraMODUL, colour-sorted, 1× ultraQXYTAINER, 1× ultraHOLDER O2	4,7	579817428
	<b>Emergency Backpack Dönges First Responder, red</b>	Filled according DIN 13155:2016-03. Designed for medical service during large events and use as SEG Backpack.	8	579805969
	<b>Emergency Backpack Dönges First Responder, DIN 14142-K, with Content, red</b>	Content according DIN 14142-K, distributed in one interior pocket size M, L and S.	2,9	579802957
	<b>Dönges Emergency backpack SEG</b>	without contents, with Interior pockets (blue, green, red, yellow)	3	579816655

## FIRST-AID BOXES & BACKPACKS

Product	Name	Description	Weight (kg)	Part no.
<b>ACCESSORIES RESCUE BACKPACKS</b>				
	<b>Content DIN 13155</b>	All content according DIN 13155:2016- 03.	2,2	579806418
	<b>Content DIN 14142:2005 Fire brigade first-aid kit small</b>	All content according DIN 14142:2005	1,4	579800149
	<b>Upgrade for Content DIN 13155</b>	To upgrade from expired DIN 13155 to current version 2016-03.	1	579817429
	<b>Dönges Boston splint set</b>	Universal splint set in a practical storage bag. Splints in different sizes keep you prepared for every situation.	0,3	579806580
	<b>Burn shield response Kit</b>	Comprehensive equipment for the treatment of multiple burns or multiple victims.	4	579802976
	<b>Shroud, black</b>	Black, strong PE film, with two pairs of PE gloves, packed in plastic bag.	0,3	579802974
	<b>Accident cover</b>	Strong zip fastener on three sides, four reinforced carrying handles and two pairs of gloves. Load capacity max.: 180 kg.	1,1	579802975
	<b>Tool backpack</b>	Without Content, without marking.	1,5	579805407

## FIRST-AID BOXES & BACKPACKS







Product	Name	Description	Weight (kg)	Part no.
	<b>Compartment Manual tools</b>	Compatible with rescue-tec Tool backpack. Without tools, contents, or backpack.	1,5	579807672
	<b>Compartment Door opener for tool set according DIN 14800-12</b>	Compatible with rescue-tec Tool backpack. Without tools, contents, or backpack.	1,5	579805774
	<b>Compartment tool set traffic accident</b>	Compatible with rescue-tec Tool backpack. Without tools, contents, or backpack.	1,5	579807670
	<b>Compartment Fall protection</b>	Compatible with rescue-tec Tool backpack. Without tools, contents, or backpack.	1,5	579807671
	<b>Backpack ultraMedic TÜRÖFFNUNG</b>	RESCUE I Backpack with Tool holders, black	4,5	579815924
	<b>Backpack ultraMedic TÜRÖFFNUNG</b>	RESCUE I Backpack with Tool holders, red	4,5	579817430

## DEFIBRILLATORS

Product	Name	Description	Weight (kg)	Part no.
	<b>Defibrillator LIFE-PAK® 1000 (Display)</b>	Robust AED (automated external defibrillator). According current resuscitation guidelines of 2010.	3,2	579800775

ACCESSORIES DEFIBRILLATORS PHYSIO CONTROL				
	<b>Vehicle mount LIFEPAK 1000</b>	Vehicle mount LIFEPAK 1000	6,7	579800778
	<b>Case hard-shell for LP 1000</b>	Case hard-shell for LP 1000	5	579800779
	<b>ECG Cable for LIFE-PAK 1000SE, 3-pole.</b>	ECG Cable for LIFEPAK 1000SE, 3-pole.	0,2	579800781
	<b>Carrying case for LIFE-PAK CR-Plus</b>	Carrying case for LIFEPAK CR-Plus	5	579800790

## PRIVACY SCREEN/SHELTERING TENT



Product	Name	Description	Weight (kg)	Part no.
	<b>Dönges Screen wall, mobile</b>	4 screen elements 180x180 cm, 1 Transport bag	16,2	579806584
	<b>Screen wall, mobile, Tredec, foldable</b>	4 Elements à 180 x 180 cm. Standard length 7 m. Setup in L or U shape possible.	15	579805780
	<b>Folding tent Ergodyne Shax 6000</b>	4 heavy-duty ground stakes, high-visibility green canopy, PU coating, Double-vented canopy for maximum airflow, Steel frame and reinforced corners, reflective accents, Large storage bag with wheels included, fits collapsed tent with canopy still on.	20,9	579806992
	<b>Side wall Ergodyne for Folding tent Shax 6000</b>	Hook & loop straps for easy attachment to the tent legs	0,7	579806993
	<b>Ergodyne Pop-Up Tent Storage Bag for Shax 6000</b>		0,52	579817448
	<b>Accommodation tent GZ 600</b>	Specially developed for fire brigades, aid organisations and disaster relief organisations, Scope of Delivery: Complete accessory set incl. tent storage bag, stakes, carrying bag and fastening material.	114	579803365

## PRIVACY SCREEN/SHELTERING TENT





Product	Name	Description	Part no.
	<b>Inflatable Tent LGZ Light</b>	<p>Lightweight inflatable ridge roof tent for rapid mobile deployments of emergency services and civil protection. Due to low weight and short set-up times, it can be used extremely flexible.</p> <p>Basic equipment:</p> <ul style="list-style-type: none"> <li>- Outer skin made of PVC coated fabric</li> <li>- Doors: Roll-up zipper door with coupling frame, supply numbers</li> <li>- Reinforced PVC floor is welded watertight to the outer skin</li> <li>- Electrical inflating unit with pressure control</li> </ul> <p>Options:</p> <ul style="list-style-type: none"> <li>- Blower with pressure control</li> <li>- Inner tent</li> <li>- Partition walls</li> <li>- Additional protection floor</li> <li>- Removable gables</li> <li>- Decontaminable inner tent</li> <li>- Lateral entrances</li> <li>- Awning</li> <li>- Solid floor</li> <li>- Water ballast tanks</li> <li>- Adaptation kit to inflate with pressurised air</li> </ul> <p>Type II, Area: 32 m<sup>2</sup>, incl. Inflating hose (connected to the tent), packaging bags, set with pegs and hammer</p>	579817431
without image	<b>Air-conditioning systems for LGZ with Pressure control</b>		579817432
	<b>Removable floor, for LGZ Light, Type II</b>		579817433
	<b>Headlining for inflatable Tent LGZ Light, Type II</b>		579817434
	<b>Inner net for ceiling part, for LGZ light, Type II</b>		579817435
	<b>Cassette floor Wood/ Aluminium, LGZ Light, Type II</b>		579817436
	<b>Partition wall Trevira CS, lengthwise, for LGZ Light, Type II</b>		579817437
	<b>Partition wall Trevira CS, cross, for LGZ Light, Type II</b>		579817438
	<b>Water ballast tank, for LGZ Light, Type II</b>		579817439



## PRIVACY SCREEN/SHELTERING TENT

Product	Name	Description	Weight (kg)	Part no.
without image	<b>Additional floor, antistatic, for LGZ Light, Type II</b>			579817440
	<b>Windows for tents LGZ resp. KF</b>	optional Accessories		579817441
	<b>Removable gable for tents LGZ resp. KF</b>			579817442
	<b>Heating system for Tents LGZ resp. KF</b>			579817443
	<b>Lateral entrances for Tents LGZ resp. KF, with two zippers</b>			579817444
	<b>Heater ACD Heater 30 L Set</b>	incl. Thermostat & chimneys, for mobile deployment as tent heater Heating capacity: 25kW, 10m Connection line 230V	64	579817445
	<b>Hose with Bag</b>	To transport heated air from heater to deployment site. Connection through spiral free sleeve and strap.		579817446
without image	<b>Fastening strap for Hose</b>			579817447
	<b>Camp/emergency bed ultraCAMP</b>	Camp/emergency bed, 100 kg load capacity	5,2	579801787

**TOOLS**

Product	Name	Description	Weight (kg)	Part no.
<b>HOOLOGAN TOOL PARATECH</b>				
<p>The "Go To" Tool – These tools are designed to pry, pound, puncture, twist and cut open or remove all types of barriers between emergency personnel and the life they are saving. The head and claw are forged from high alloy steel, heat-treated for maximum strength, then fitted to a 2.5 cm stress proof bar. The bar has machine grooved non-slip grips. The Hooligan Tool features a claw that is gently curved for maximum prying leverage. The claw opening is parallel and fits over locks, hasps, and many door bars. It can also be used as a nail puller and a gas shut off during emergencies. The "Highway Hooligan Tool" features a metal cutting claw with a machine sharpened metal cutter that uses the can opener principle to cut heavy gauge metal and composites.</p>				
	<b>Hooligan tool Paratech with Pike</b>	Diameter 25 mm, Multi-purpose forcibly entry tool	0,16	579803181
			0,16	762 mm
			0,16	579803182
	<b>Hooligan tool Paratech with metal cutting claw</b>	Diameter 25 mm, Multi-purpose forcibly entry tool	0,16	914 mm
			0,16	579803183
			0,16	1067 mm
<b>ACCESSORIES HOOLOGAN TOOL</b>				
	<b>Carrying system for Hooligan tool</b>	More possibilities by combining two tools. Higher penetration force. Easy transport through special carrying strap.	0,16	579803188
	<b>Carrying strap for Hooligan tool</b>		0,4	579803189

## TOOLS

Product	Name	Description	Weight (kg)	Part no.
	<b>Firefighter axe Dönges FireAXEss</b>	Especially developed to use in fire brigades. The axe is equipped with a 3 kg hardened steel axe head and a robust fibreglass handle	4,4	579815807
	<b>Hooligan tool combination, Hooligan-Tool/ FireAXEss</b>	Consists of: Hooligan tool/FireAXEss	9,4	579817449
	<b>Fire Bird ICONOS</b>	Powder-coated phosphorescent, features axe blade on one side, cantilever with big leverage effect on the other.	1	579808444
	<b>Firefighter axe FA, 900 mm</b>	DIN 14900. Sturdy version. Red-painted head with ground cutting edge and lever cutter at other end. With oval hickory handle with transparent varnish.	2,5	579803195
	<b>Firefighter axe FAK, 900 mm</b>	DIN 14900. Fibreglass handle with non-slip rubber handle.	3	579803196
	<b>Firefighter axe with NUPLA handle</b>	Handle is almost unbreakable because of its special design and high proportion of fibreglass. Good electric insulation.	3,1	579803197
	<b>Firefighter axe Pulaski with NUPLA handle</b>	Handle is almost unbreakable because of its special design and high proportion of fibreglass. Good electric insulation.	1,6	579804148
	<b>Protective bag for Fire-fighter axe</b>	DIN 14900. For all Firefighting axes with carrying strap.	0,4	579803199
	<b>Biel Tool Paratech</b>	Multi-purpose tool with axe blade, Spanner Wrench function, Nail pulling feature, Chisel & Prying surface, Sheet metal cutting claw, Gas shut off feature, squared pike to avoid jams and Coupling key B+C	1,5	579804827
	<b>Biel Tool Paratech with holster</b>	Multi-purpose tool with axe blade, Spanner Wrench function, Nail pulling feature, Chisel & Prying surface, Sheet metal cutting claw, Gas shut off feature, squared pike to avoid jams and Coupling key B+C	1,8	579803177

## TOOLS

Product	Name	Description	Weight (kg)	Part no.
	<b>Pry-Axe Paratech with Pike</b>	Axe blade, Nail pulling feature, Ground splitter, Metal cutting claw. Length closed/extended: 470/655 mm.	3,4	579803178
	<b>Pry-Axe Paratech with Metal cutting claw</b>	Axe blade, Nail pulling feature, Ground splitter, Metal cutting claw. Length closed/extended: 470/655 mm.	3,2	579803179
	<b>Fire brigade hatchet FBD, with triangular key</b>	DIN 14924-FBD, Red-painted head with ground splitter and narrow pike at the other side, with oval tubular steel handle inserted into the head. Non-slip rubber hand guard with integrated triangular key for bollards, hydrants etc. The integrated bollard key makes this quality hatchet ever more useful to firemen.	1,2	579803200
	<b>Hatchet protection bag</b>	similar DIN 14924, high-quality leather. Metal-enforced edges, optimum fit.	0,2	579803202
	<b>Carpenter Nail iron / crowbar 800 mm</b>	Hexagonal. Features pike on one side, bent head with nail claw on the other side.	1,8	579803270
	<b>Crowbar 700 mm</b>	DIN 14853. Features hardened tip on one side & bent, hardened claw on the other side.	3,3	579803190
	<b>1200 mm</b>		6,5	579803191
	<b>1500 mm</b>		8	579803192
	<b>Bolt cutter 910 mm, Import version</b>	Cutting capacity 13 mm	5,1	579803248
	<b>Bolt cutter 610 mm, Professional, VBW</b>	Cutting capacity 9 mm/19 HRc	2,8	579803249
	<b>Bolt cutter 910 mm, Professional, VBW</b>	Cutting capacity 13 mm <sup>2</sup> /19 HRc	6,4	579803250
	<b>Bolt cutter 650 mm, with Catch hook, Type A</b>	With powder-coated tubular steel handles and PVC grips. The galvanised catch hook allows the material that is being cut to be threaded in. Cutting capacity 9 mm <sup>2</sup> /19 HRc.	2,4	579803251
	<b>Bolt cutter 955 mm, with Catch hook, Type A</b>	With powder-coated tubular steel handles and PVC grips. The galvanised catch hook allows the material that is being cut to be threaded in. Cutting capacity 13 mm <sup>2</sup> /19 HRc.	6,5	579803252
	<b>Bolt cutter with Nupla fibre glass grips, 910 mm</b>	Extremely strong and insulating. Suitable for any type of use. Particularly cutting through hard material such as lock shackles is no problem for these screw cutters.	1,7	579809353

## TOOLS

Product	Name	Description	Weight (kg)	Part no.
	<b>Nail iron Gorilla Bar</b>	Features pike on one side, bent head with nail claw on the other side. Length 350mm Length 600mm Length 900mm	2	579805045 579804973 579805255
	<b>Nail iron</b>	Hexagonal. Features pike on one side, bent head with nail claw on the other side. Length 400mm Length 600mm	1 1,8	579805686 579807986
	<b>Splitting hammer</b>	Robust ash knob handle. Length 900 mm. Head weight 3000 g	4	579803203
	<b>Splitting hammer</b>	Length: 870mm, Quality splitting hammer with fibreglass handle. Virtually inseparable connection of head and stem, therefore increased safety, and long service life.	4,11	579804748
	<b>Sledge hammer 5 kg</b>	DIN 1042. Ash knob handle. High-endurance version.	5,5	579803271
	<b>Wooden axe B2</b>	DIN 7294. Berlin shape, ash knob handle.	2,7	579803242
	<b>Jigsaw 350 mm</b>	DIN 7258. Made of best electric steel, polished, set and sharpened, with lacquered wooden handle.	0,3	579803246
	<b>Hacksaw 525 mm</b>	Easy replacement and clamping system of the blade	0,6	579805745
	<b>Hacksaw 760 mm</b>	Sturdy oval steel handle. Ergonomic 2-component handle. Saw blade with hardened teeth.	0,7	579803243
	<b>Hacksaw 915 mm</b>		0,9	579803244
	<b>3-component hammer 2 kg</b>	DIN 6475. With ash knob handle. Robust import quality .	2,2	579803320
	<b>Locksmith hammer</b>	DIN 1041. With Ash knob handle. Reliable quality even for tough continuous use.	0,6	579803318
	<b>Manhole hammer</b>	Special hammer for levering open or opening manhole covers and hydrants. The special shape and sturdy design.	0,8	579805645
	<b>Roofing hammer</b>	DIN 7239. With roughened track and nail groove, fibreglass handle, non-slip rubber handle.	0,6	579803319
	<b>Wooden hammer, Form B</b>	DIN 7462. Size: Ø 90 mm.	1,2	579803317





## TOOLS

Product	Name	Description	Weight (kg)	Part no.
	<b>Flat chisel</b>	DIN 6453	0,6	579803322
	<b>Multifunction spanner MFS</b>	The MFS multifunction spanner can be used for opening, closing, measuring, testing, and installing	0,14	579803263
	<b>New construction key Model 3678</b>	For profile cylinder locks (17 mm Ø ), with internal square insert 6, 7 and 8 mm and bottle opener, square hole 6-10 mm, 3 mm Allen key.	0,12	579806203
	<b>New construction key Model 3679</b>	For profile cylinder locks (17 mm Ø ), with internal square insert 6, 7 and 8 mm as well as bottle opener.	0,2	579803262
	<b>Spanner for barrier posts</b>	DIN 3222, Triangular key M10, simple socket wrench made from galvanised tube material. With handle.	0,2	579805050
	<b>Universal cabinet key with Adapter and Bit</b>	For door handles, window handles, heating vents, plumbing, new construction, technical closures and many more.	0,1	579806436
	<b>Triangular socket wrench M 12, DIN 22417, galvanized</b>	Cost-effective, simple bollard wrench made from galvanised tube material. With handle. Suitable for all barrier posts in acc. with DIN 3222.	0,2	579803264
	<b>Spanner for barrier posts, Universal</b>	Bollard wrench made from annealed cast iron, especially for fire brigade and emergency vehicles. Suitable for all barrier posts in acc. with DIN 3222 and barriers.	0,4	579803265
	<b>Combination wrench - Set</b>	DIN3113-A. 8/9/10/11/13/14/17/19 mm	3,4	579804474
	<b>Double open-end wrench - Set DIN 3110, 12 pieces</b>	DIN 3110. 6x7 / 8x9 / 10x11 / 12x13 / 14x15 / 16x17 / 18x19 / 20x22 / 21x23 / 24x27 / 25x28 / 30x32 mm.	2,2	579803326
	<b>Double ring wrench - Set DIN 838, 12 pieces</b>	DIN 838. 6x7 / 8x9 / 10x11 / 12x13 / 14x15 / 16x17 / 18x19 / 20x22 / 21x23 / 24x27 / 25x28 / 30x32 mm.	3,4	579803327
	<b>Screwdriver - Set</b>	For slotted screws 3, 4, 5,5, 6,5 mm For Philips screws PH 1, PH 2	0,3	579804477

## TOOLS

Product	Name	Description	Weight (kg)	Part no.
	<b>Socket set, 1/2" 24 pieces</b>	Hexagon socket wrench inserts with flank drive 10-32 mm. Lever switch hatchet. Handle with sliding piece. Extensions 125 and 250 mm. Universal joint.	1,8	579803328
	<b>Hex key - Set</b>	2-14 mm, Hex key set for hexagon socket screws, in plastic bag, ISO 2936 K (DIN 911)	0,3	579804984
	<b>Combination pliers 180</b>	DIN 5244. Insulated up to 1000 V.	0,3	579803321
	<b>Rescue knife PRT- II, Fire brigade</b>	with Seatbelt separator, Window breaker, special key to replace and adjust the blade.		579817450
	<b>Rescue knife Economy II</b>	with Seatbelt separator & window breaker	0,2	579805913
	<b>Holster for Rescue knife</b>	Suitable for all PRT knives, Rescue Tool I and „Economy“ as well as other knives, depending on size.	0,2	579805914
	<b>Rescue scissors Köln</b>	Handle in bright red colour. Include a practical key ring to attach the scissors to a safety strap.	0,2	579804644
	<b>Rescue shears Robin</b>	Also cuts sheet metal and can be used as an emergency hammer. Incl. wall and vehicle mount.	0,5	579804653
	<b>Cap knife</b>	With replaceable, super-sharp blade that cuts at three sides. The special shape ensures that cutting is reliable and effortless, particularly regarding ropes and cables.	0,1	579802934
	<b>Cover for Cap knife</b>		0,1	579802935
	<b>Belt knife</b>	Slightly curved, stainless, super-sharp steel blade 160 mm long, with safety knob at the tip and black plastic handle.	0,1	579802932
	<b>Cover for Belt knife</b>		0,1	579802933

## TOOLS

Product	Name	Description	Weight (kg)	Part no.
without image	<b>Belt separator SOS-Cutter, Dönges</b>	Can be kept anywhere, sharp blade effortlessly cuts through seat belts and clothing. Blade is protected and prevents injuries.	0,2	579802936
	<b>Rescue hammer SALVEX</b>	Belt cutter and rescue hammer made of glass fibre reinforced, red plastic with impact mandrel made of specially hardened steel. Complete with black mounting bracket for easy installation in the vehicle.	0,2	579802938
	<b>Tool kit sparkless, 4-teilig</b>	For rescue vehicles RW (old standard DIN 14555-T3), made from special bronze (copper beryllium).	8,5	579803281
	<b>Water pump pliers 250 mm, sparkless</b>	For use in explosive environments.	0,4	579803282
	<b>Corner pipe wrench sparkless 2"</b>	For use in explosive environments. Swedish design.	2,4	579803283
	<b>Corner pipe wrench sparkless 1½"</b>		1,8	579803284
	<b>Flat chisel 300 mm, sparkless</b>	For use in explosive environments. Made from special bronze.	0,7	579803285



# REAL HEROES

**Global**  
www.globales112.com

**DON'T WEAR SUITS OF ARMOUR**

**\*BUT COOL PERSONAL  
PROTECTIVE EQUIPMENT  
(PPE).**



We've got what it takes.  
**Exclusively at Dönges!**

**Dönges**  
FIRE & RESCUE

## NON-SPARKING TOOLS

Product	Name	Description	Weight (kg)	Part no.
	<b>Pin punch Set, non-sparking</b>	Form similar DIN 6458. Length 120 mm each, Material: Special bronze CuAl10Ni	0,135	579803286
	<b>Copper hammer 1 kg, non-sparking</b>	For use in explosive environments. With Ash knob handle.	1,2	579803287
	<b>Railroad pick, non-sparking</b>	For use in explosive environments. With oval eye and Ash knob handle.	4,1	579803288
	<b>Spade, non-sparking</b>	For use in explosive environments. Blade 185 x 280 mm. With Ash knob handle, D-Handle.	3	579803289
	<b>Edge shovel, non-sparking</b>	For use in explosive environments. Blade 220 x 310 mm. With long ash knob handle.	2,4	579803290
	<b>Barrel spanner, non-sparking</b>	For use in explosive environments. For 22 barrel spanners. Made from Special bronze.	1,4	579803291





## TOOLS FOR ASSISTANCE SERVICES

Product	Name	Description	Weight (kg)	Part no.
	<b>Inteltool telescopic fibreglass handle design, Size S</b>	0,61-1,22 m, straight, Twist lock and screw lock, continuously adjustable, insulated against cold and electric voltage	1,2	579808894
	<b>Size M</b>	As above, but 1,22-2,44 m	1,6	579808895
	<b>Size M, D-Handle</b>	As above, but 1,22-2,44 m, D-Handle	1,6	579808896
	<b>Size L</b>	As above, but 2,44-4,88 m	3,0	579808898
	<b>Inteltool tool head, fire rake</b>	suitable for all telescopic fibreglass handles by Dönges, space-saving storage	0,79	579808900
	<b>Inteltool tool head, Fire swatter</b>	suitable for all telescopic fibreglass handles by Dönges, space-saving storage	2,3	579808901
	<b>Inteltool tool head, McLeod Tool</b>	suitable for all telescopic fibreglass handles by Dönges, space-saving storage	0,79	579808902
	<b>Inteltool tool head, branch saw</b>	suitable for all telescopic fibreglass handles by Dönges, space-saving storage	0,4	579808903
	<b>Inteltool tool head, Ceiling hook DIN-Form</b>	suitable for all telescopic fibreglass handles by Dönges, space-saving storage	0,8	579808905
	<b>Inteltool telescopic fibreglass handle design, Size M, Manure hoe</b>	1,22-2,44 m, straight, Twist lock and screw lock, continuously adjustable, insulated against cold and electric voltage	2,4	579808910
	<b>Size L</b>	2,44-4,88 m	3,8	579808911
	<b>Inteltool telescopic fibreglass handle design, Size M, fire rake</b>	1,22-2,44 m, straight, Twist lock and screw lock, continuously adjustable, insulated against cold and electric voltage	2,4	579808912
	<b>Size L</b>	2,44-4,88 m	3,8	579808913

## TOOLS FOR ASSISTANCE SERVICES







Product	Name	Description	Weight (kg)	Part no.
	<b>Inteletool telescopic fibreglass handle design, Size M, Fire swatter</b>	1,22-2,44 m, straight, Twist lock and screw lock, continuously adjustable, insulated against cold and electric voltage	3,9	579808914
	<b>Size L</b>	2,44-4,88 m	5,3	579808915
	<b>Inteletool telescopic fibreglass handle design, Size M, McLeod- Tool</b>	1,22-2,44 m, straight, Twist lock and screw lock, continuously adjustable, insulated against cold and electric voltage	2,4	579808916
	<b>Inteletool telescopic fibreglass handle design, Size L</b>	2,44-4,88 m	3,8	579808917
	<b>Inteletool telescopic fibreglass handle design, Size M, Branch saw</b>	1,22-2,44 m, straight, Twist lock and screw lock, continuously adjustable, insulated against cold and electric voltage	2	579808918
	<b>Inteletool telescopic fibreglass handle design, Size L</b>	2,44-4,88 m	3,4	579808919
	<b>Inteletool telescopic fibreglass handle design, Size M, Ceiling hook DIN</b>	1,22-2,44 m, straight, Twist lock and screw lock, continuously adjustable, insulated against cold and electric voltage	2,4	579808920
	<b>Size L</b>	2,44-4,88 m	3,8	579808921
	<b>Adapter Inteltool for Standard spigot DIN 14640</b>	This adapter fits into all Inteltool fibreglass handles and adapts to a standard pin according to DIN 14640. The pin can be used, for example, to attach the hook of the standard tear hook, to adapt the forest fire pawl (210812) to the Inteltool system or as a temporary tripod for headlamps.	0,12	579808922
	<b>Ceiling hook OV, without Extension, Telescopic handle design</b>	DIN 14851:2014-09-OV. Length 2,0 - 3,2 m.	5,1	579803075
	<b>Ceiling hook MV, with Extension, Telescopic handle design</b>	DIN 14851:2011-10-MV. Length 2,0 - 4,8 m.	3	579803076
	<b>Ceiling hook Type A - Ceiling hook with extension</b>	According expired DIN 14851. Type A: 5 m long (DIN 14851-5), consists of Type C and V.	8,3	579803077
	<b>Ceiling hook Type C - Pull hook</b>	According expired DIN 14851. Ceiling hook, consists of hook part (DIN14851-1), wooden handle 2,5 m, coupling part H (DIN14851-2).	4,8	579803078
	<b>Telescopic ceiling hook Leader, fibreglass</b>	Insulated up to 20.000 V (retracted, in wet environment). Body according norms IEC61235 & IEC60855. Not according DIN 14851.	3	579804078

## TOOLS FOR ASSISTANCE SERVICES

Product	Name	Description	Weight (kg)	Part no.
	<b>Ceiling hook Type V - Extension</b>	According expired DIN14851. Type V: Extension (DIN 14851-3), consists of wooden handle 2,5 m and Coupling part V.	4	579803079
	<b>Ceiling hook NUPLA fibreglass handle, D-Handle, 1,8 m</b>	Sturdy hook parts, forged.	2,9	579803080
	<b>Ceiling hook Type 2 - light</b>	with Handle 35 mm Ø, two pieces, with two couplings, 2,5 m	3,6	579804003
	<b>Ceiling hook NUPLA Roof Kit</b>	4 pieces	7,6	579805553

### COMBINATION REPLACEMENT SYSTEM







This replacement combination system makes it possible to use different tools with a Nupla fibre glass handle. This makes the use of this extremely sturdy and robust tool handle even more attractive. Of course, just like the extension and the different tools, the replacement handle has all the benefits of the special Nupla material. A maximum of three parts can be combined.

	<b>Ceiling hook part for replacement combination system, 90 cm</b>	Quick tool change, sturdy D-Handle for secure grip	1,9	579806190
	<b>Dönges D-Handle part for replacement combination system, 90 cm NUPLA</b>		1,7	579806191
	<b>Dönges Handle extension for replacement combination system, 90 cm NUPLA</b>		0,9	579806192
	<b>Handle extension for replacement combination system, 120 cm</b>	Quick tool change	1,1	579806782
	<b>Fire swatter, with Quick lock, without Handle</b>	Cover: Width approx. 13 cm/49 cm, Length approx. 39 cm, Spring steel sheet: Strength approx. 0,5 mm, Width approx. 50 mm	1,3	579802903
	<b>Handle for fire swatter</b>	Handle thickness Ø 28 mm. Pine.	0,9	579802904



## TOOLS FOR ASSISTANCE SERVICES

Product	Name	Description	Weight (kg)	Part no.
	<b>Spade with T-Handle</b>	DIN 20127. Blade 185 x 280 mm, with shortened Ash knob handle.	2,2	579806945
	<b>Spade with CY-Handle</b>	DIN 20127. Blade 185 x 280 mm, with shortened Ash knob handle	2,2	579803253
	<b>Folding spade, Import version</b>	Folded 240 mm long, Blade size 210 x 155 mm.	1,1	579803254
	<b>Folding spade Original Germany army version</b>	Entirely made of metal, colour: olive green. Blade size 210 x 155 mm. Folded 240 mm.	1,18	579806207
	<b>Manure hoe</b>	Four times, long, beech handle, handle socket.	1,4	579803255
	<b>Manure fork</b>	Four times, long & bent beech handle, handle socket.	1,7	579803256
	<b>Railroad pick</b>	DIN 20109. Gr. 3,5 kg. With oval eye and Ash knob handle.	4,3	579803260
 	<b>Hoopoe hoe</b>	with oval blade Ideal spade and Handle	2,5	579803392
	<b>Blade guard for Hoopoe hoe with oval blade</b>		0,06	579803393
	<b>Frankfurt shovel</b>	DIN 20121. Gr. 5, Blade 300 x 270 mm. Long beech handle, Length 1300 mm.	2	579803257

## TOOLS FOR ASSISTANCE SERVICES

Product	Name	Description	Weight (kg)	Part no.
	<b>Holsteiner shovel</b>	DIN 20120. Blade 270 x 250 mm. Long beech handle, Length 1300 mm.	1,8	579803258
	<b>Edge shovel, Light metal Size 9</b>	Without protective edge, with 6-fold riveted sleeve. Blade 380 x 380 mm	1,1	579804848
	<b>Aluminium shovel Size 9</b>	with protective edge, Blade 380 x 380 mm.	1,06	579804671
	<b>Sand shovel Bavarian design, 1.600 mm</b>	with Ash knob handle	2,3	579806323
	<b>Pioneer shovel 960 mm</b>	with Ash knob handle, Blade 300 x 240 mm	2,1	579806840
	<b>Water slider</b>	Made of metal with quick fastener and double synthetic foam rubber strip.	0,6	579803261

## TOOLS FOR ASSISTANCE SERVICES

Product	Name	Description	Weight (kg)	Part no.
	<b>Piassava broom 32 cm with Handle</b>	Handle made from Beech wood, 1400 mm.	1	579803259
	<b>Piassava broom 40 cm with Handle</b>	Handle made from Beech wood, 1400 mm.	1,2	579805276
	<b>Road broom Power Stick Elaston 40 cm, with Handle</b>	Handle 140 cm, Ø 24 mm, flat, without rounded head, blunt	1,2	579805619
	<b>Shovel handle, Length 1300 mm</b>		0,9	579804849
	<b>Broom handle Piassava 1400 mm</b>	Broom handle with metal thread.	0,3	579806386
	<b>Broom handle 1400 mm</b>	Ø 24 mm, flat, without rounded head, blunt	0,3	579804859



## TOOL BOXES AND CASES

Product	Name	Description	Weight (kg)	Part no.
	<b>Fire brigade Hand tool box, complete, Dönges</b>	Content according DIN 14881:2013-12-FWka. Box with aluminium compartments and marking „Hand tools“. WxHxL: 400x150x600mm	21	579803210
	<b>Fire brigade Tool set DIN 14881, without box</b>	Content according DIN 14881:2013-12-FWka	14,8	579803212
	<b>Fire brigade Tool box, empty</b>	Box for tools according DIN 14881:2013-12 and aluminium compartments and marking „Hand tools“. WxHxL: 400x150x600mm	6	579803211
	<b>Fire brigade Tool box</b>	with Foam insert complete, Fire brigade Tool box similar DIN 14881 with Foam insert in Dönges Firebox	21	579815099
	<b>Power tool box, complete, Dönges</b>	Content according DIN 14885:2013-12. Box with aluminium compartments and marking „Tool box E“. WxHxL: 300x150x400mm	7,2	579803213
	<b>Power tool set DIN 14885, without Box</b>	Content according DIN 14885:2013-12	6,4	579803215
	<b>Power tool box, empty</b>	Box for tools according DIN 14885:2013-12 and aluminium compartments. Marking „Tool box E DIN 14885 - Only for qualified electricians and instructed personnel“ WxHxL: 300x150x400mm	3,9	579803214
	<b>Power tool box, complete, Dönges</b>	With Foam insert, Content according DIN 14885, Marking „Tool boxes E“. WxHxL: 300x150x400mm		579815100
	<b>Traffic accident tool box, complete, Dönges</b>	Content according DIN 14800-13:2013-12. Box with aluminium compartments and marking „Traffic accident“. WxHxL: 400x220x600mm	14,2	579815101
	<b>Traffic accident - Set DIN 14800</b>	Content according DIN 14800-13:2013-12	7,9	579803218
	<b>Traffic accident box, empty</b>	Box for tools according DIN 14800- 13:2013-12 and with aluminium compartments. Marking: „Traffic accident DIN 14800-13“ WxHxL: 400x220x600mm	6,3	579803217
without image	<b>Traffic accident tool box, complete, Dönges</b>	With Foam insert, Content according DIN 14800-13, Marking „Traffic accident “. WxHxL: 400x220x600mm		579818228

## TOOL BOXES AND CASES

Product	Name	Description	Weight (kg)	Part no.
	<b>Chimney sweeper tool set DIN 14800-SSWK, complete</b>	Content according DIN 14800-4:2013-12. Box with aluminium compartments and marking „Chimney sweeper tools“. WxHxL: 300x220x400mm	25	579803219
	<b>Chimney sweeper Set, without Box, Dönges</b>	Content according DIN 14800-4:2013-12	21,7	579803221
	<b>Chimney sweeper tool box DIN 14800-SSWK, empty</b>	Box for tools according DIN 14800- 13:2013-12 with aluminium compartments and marking „Chimney sweeper tools DIN 14800-4“ WxHxL: 400x220x600mm	3,4	579803220
	<b>Tool set metal 1 DIN 14800-WKM 1, complete</b>	Content according DIN 14800-9:2013-12 Box with aluminium compartments and marking „Tools metal 1 DIN 14800-9“. WxHxL: 400x150x600mm	24,7	579803222
	<b>Tools metal 1 Set DIN 14800</b>	Content according DIN 14800-9:2013-12	17,8	579803224
	<b>Tool box metal 1 DIN 14800-WKM 1, empty</b>	Box for tools according DIN 14800-9:2013- 12 with aluminium compartments and marking „Tools metal 1 DIN 14800-9“ WxHxL: 400x150x600mm	5,6	579803223
	<b>Tool box metal 2 DIN 14800-WKM 2, complete</b>	Content according DIN 14800-9:2013-12 Box with aluminium compartments and marking „Tools metal 2 DIN 14800-9“. WxHxL: 400x150x600mm	18,2	579803225
	<b>Tools metal 2 Set DIN 14800</b>	Content according DIN 14800-9:2013-12	11,2	579803227
	<b>Tool box metal 2 DIN 14800-WKM 2, empty</b>	Box for Tools according DIN 14800-9:2013- 12 with aluminium compartments and marking „Tools metal 2 DIN 14800-9“ WxHxL: 400x150x600mm	5,6	579803226
	<b>Tool boxes Wood according DIN 14800-WKH, complete</b>	Content according DIN 14800-9:2013-12 Box with aluminium compartments and marking „Tool kit Wood DIN 14800-9“. WxHxL: 400x150x600mm	25,5	579803228
	<b>Tools Wood Set DIN 14800</b>	Content according DIN 14800-9:2013-12	18,1	579803230
	<b>Tool boxes Wood according DIN 14800-WKH, empty</b>	Box for Tools according DIN 14800-9:2013- 12 with aluminium compartments and marking „Tool set Wood DIN 14800-9“ WxHxL: 400x150x600mm	5,9	579803229
	<b>Sealing kit box DIN 14800-DK, complete</b>	Content according DIN 14800-10:2013-12 Box with aluminium compartments and marking „Sealing set DIN 14800-10“. WxHxL: 300x150x400mm	5,6	579803231
	<b>Sealing kit DIN 14880</b>	Content according DIN 14800-10:2013-12	2,4	579803233
	<b>Sealing kit box DIN 14800-DK, empty</b>	Box for Tools according DIN 14800- 10:2013-12 with aluminium compartments and marking „Sealing set DIN 14800-10“ WxHxL: 300x150x400mm	3,3	579803232

## TOOL BOXES AND CASES

Product	Name	Description	Weight (kg)	Part no.
	<b>Locking tools DIN 14800-SWK, complete</b>	Content according DIN 14800-12:2013-12 Box with aluminium compartments and marking „Locking tools DIN 14800-12“. WxHxL: 300x150x400mm	9,4	579803234
	<b>Locking tools Set DIN 14800-SWK</b>	Content according DIN 14800-12:2013-12	4,3	579803236
	<b>Locking tools DIN 14800-SWK, empty</b>	Box for Tools according DIN 14800- 12:2013-12 with aluminium compartments and marking „Locking tools DIN 14800-12“ WxHxL: 300x150x400mm	3,8	579803235
	<b>Consumables tool box, complete</b>	Content according DIN 14800-14:2013-12 Box with aluminium compartments and marking „Consumables DIN 14800-14“. WxHxL: 300x150x400mm	9,3	579803237
	<b>Consumables Set DIN 14800</b>	Content according DIN 14800-14:2013-12	6	579803239
	<b>Consumables tool box, empty</b>	Box for Tools according DIN 14800- 14:2013-12 with aluminium compartments and marking „Consumables DIN 14800-14“ WxHxL: 300x150x400mm	3,3	579803238
	<b>Environmental damage tool box, complete</b>	Content according DIN 14800-15:2013-12 Box with aluminium compartments and marking „Environmental damage DIN 14800-15“ WxHxL: 400x220x600mm	13,9	579803352
	<b>Environmental damage tool box, empty</b>	Box for Tools according DIN 14800- 15:2013-12 with aluminium compartments and marking „Environmental damage DIN 14800-15“ WxHxL: 400x220x600mm	5,8	579803353
	<b>Multipurpose hoist Set MZ 16 „Hoist“</b>	Redesigned set according to DIN 14800-5:2013-12 with a tensile force of up to 16 kN. WxHxL: 400x220x600mm	65	579803129
	<b>FireBox, Multipurpose hoist DIN 14800 MZ 16, empty</b>	Size: 1, with Marking Multipurpose hoist MZ 16 WxHxL: 400x220x600mm	6	579806678
	<b>FireBox, Accessories for MZ 16, empty</b>	Size: 1, with Marking Accessories for multipurpose hoist MZ 16 WxHxL: 400x220x600mm	6	579806679





## TOOL BOXES AND CASES

Product	Name	Description	Weight (kg)	Part no.
	<b>Multipurpose hoist-Set MZ 32 „Hoist“</b>	Reconfigured Set according DIN 14800-5:2013- 12 with Pulling force up to 32 kN.	133	579803130
	<b>FireBox Multipurpose hoist DIN 14800 MZ 32 with MDF compartments</b>	Size: 6, with Marking Multipurpose hoist MZ 32, Box 1 WxHxL: 400x330x800mm	3,9	579806488
	<b>FireBox Multipurpose hoist DIN 14800 MZ 32 with MDF compartments</b>	Size: 6, with Marking Multipurpose hoist MZ 32, Box 2 WxHxL: 400x330x800mm	3,9	579806489
	<b>Equipment Module Compressed air DIN 14530-8</b>	Measuring range: 0,7 - 7 bar, G1/4" quick couplings, Adaptor G1/4" for vehicle compressed air incl.	2,9	579806611
	<b>Equipment Module coarse cleaning/decontamination L1</b>	New norm DIN 14800-18, Bbl. 12. Set for quick coarse cleaning and decontamination at deployment site.	2,9	579803350
	<b>Equipment Module Decontamination L2</b>	Neue Norm DIN 14800-18, Bbl. 12: Set for quick coarse cleaning and decontamination at deployment site.	6,1	579803351
	<b>Tool boxes 5 pieces, empty, 430 x 210 x 200 mm</b>	With Handle and hole for bar lock.	3,8	579803240
	<b>Tool boxes 5 pieces, empty, 530 x 200 x 200 mm</b>		4,5	579805058
without image	<b>Pump tools and tool box</b>	Without Box.	7	579805061
	<b>Tool kit for Tool boxes</b>	6 piece Set in cardboard box.	3,9	579803241

## TOOL BOXES AND CASES

Product	Name	Description	Weight (kg)	Part no.
	<b>Fire brigade box Firebox®, Zarges, Size 1 - 600 x 400 x 220 mm</b>	DIN 14880. Empty. Without Compartments. Without Marking. Incl. lid. Lockable through padlock	6,2	579803204
	<b>Fire brigade box Firebox®, Zarges, Size 2 - 400 x 300 x 220 mm</b>	DIN 14880. Empty. Without Compartments. Without Marking. Incl. lid. Lockable through padlock	3,5	579803205
	<b>Fire brigade box Firebox®, Zarges, Size 3 - 600 x 400 x 150 mm</b>	DIN 14880. Empty. Without Compartments. Without Marking. Incl. lid. Lockable through padlock	5,1	579803206
	<b>Fire brigade box Firebox®, Zarges, Size 4 - 400 x 300 x 150 mm</b>	DIN 14880. Empty. Without Compartments. Without Marking. Incl. lid. Lockable through padlock	3,3	579803207
	<b>Fire brigade box Firebox®, Zarges, Size 5 - 600 x 265 x 220 mm</b>	DIN 14880. Empty. Without Compartments. Without Marking. Incl. lid. Lockable through padlock	4,5	579803208
	<b>Fire brigade box Firebox®, Zarges, Size 6 - 800 x 330 x 400 mm</b>	DIN 14880. Empty. Without Compartments. Without Marking. Incl. lid. Lockable through padlock	7,9	579803209
	<b>Firebox Lifting bag accessories DIN 14800- HZK with MDF compartments</b>	Size: 6, with Marking Lifting bag Accessories DIN 14800-11	3,9	579805471
	<b>Transportation case Fire-box® Zarges, perforated - 600x400x220 mm</b>	DIN 14880. Size 1.	3,9	579804464
	<b>Transportation case Fire-box® Zarges, perforated - 600x400x150 mm</b>	DIN 14880. Size 3.	3,1	579805795

## TOOL BOXES AND CASES

Product	Name	Description	Weight	Colour	Part no.
	<b>Stackable transport box Dönges, 400x300x175 mm</b>	Without lid, to store many equipment items in vehicle or appliance room.	1,6	red	579805886
	<b>Transport box 400 x 300 x 210 mm, Plastic</b>	Without lid, to store many equipment items in vehicle or appliance room.	1,7	grey	579804734
	<b>Transport box 400 x 300 x 320 mm, Plastic</b>	Without lid, to store many equipment items in vehicle or appliance room.	0,97	grey	579805909
	<b>Transport box 600 x 400 x 175 mm, Plastic</b>	Without lid, to store many equipment items in vehicle or appliance room.	1,7	grey	579804733
	<b>Transport box 600 x 400 x 210 mm, Plastic</b>	Without lid, to store many equipment items in vehicle or appliance room.	1,7	grey	579804098
	<b>Transport box 600 x 400 x 270 mm, Plastic</b>	Without lid, to store many equipment items in vehicle or appliance room.	1,7	grey	579805082
	<b>Transport box 600 x 400 x 320 mm, Plastic</b>	Without lid, to store many equipment items in vehicle or appliance room.	1,7	grey	579805429
	<b>Transport box 600 x 400 x 320 mm, Plastic</b>	Without lid, to store many equipment items in vehicle or appliance room.	1,7	red	579806196
	<b>Lid</b>	For stackable Transport box 400 x 300 mm. Snaps shut with fastening clip	0,37	black	579804321
	<b>Lid</b>	For stackable Transport box 600 x 400 mm. Snaps shut with fastening clip	0,75	grey	579805225

## POWER TOOLS

Product	Name	Description	Weight (kg)	Part no.
	<b>Cordless rotary hammer Bosch GBH 18V-21</b>	Battery voltage: 18V/4Ah, Drilling Ø Concrete: 4-21mm, Drilling Ø Wood max.: 30mm, Drilling Ø Metal max.: 13mm, Items: Cordless rotary hammer GBH 18V-21, Battery GBA 18V 4.0Ah, Quick charger GAL 18V-40 Professional, Depth stop, Machine cloth, L-BOXX 136	6,17	579817731
	<b>Cordless drill GSR 18-2 Li Plus</b>	Battery voltage 18 V. Drilling diameter. Steel/Wood max. 10/35 mm. Drill chuck range min.1,5, max.13 mm.	1,7	579808059
	<b>Cordless impact drill Bosch GSB 18-2-LI Plus</b>	Battery voltage 18 V. Quick-action drill chuck with 13 mm tool holder for common accessories.	4,95	579808109
	<b>Rotary hammer Bosch GBH 2-26 Professional</b>	Rated speed 0-900 min <sup>-1</sup> , Impact rate 0-4000 min <sup>-1</sup> , Rated input power 830 W, SDS-Plus tool holder	3,15	579806891
	<b>Demolition hammer Bosch GSH 11 VC</b>	Impact rate at rated speed 900-1700 min <sup>-1</sup> ; rated input power 1700 W ; Machining tool sharp chisel, Single-blow energy 23 J	16	579806472
	<b>Rotary hammer Bosch GBH 8-45 D</b>	1500 W. Impact rate at rated speed 0-305 min <sup>-1</sup> . Single-blow energy 12,5 J. Drilling Ø core cutters 125 mm.	12,5	579803151
	<b>Impact drill Bosch Type GSB 21-2 RCT Professional</b>	Rated input power 1300 W. Max. Torque 43 Nm. Drill chuck range 1,5 - 13 mm. Drilling Ø Wood/Steel/Concrete max. 40/16/22 mm.	2,4	579804850

## POWER TOOLS

Product	Name	Description	Weight	Colour	Part no.
<b>ACCESSORIES DRILLS</b>					
	<b>SDS plus-B drill bit pack, 7 pieces</b>	Content: 5 x 110, 6 x 110, 8 x 110, 6 x 160, 8 x 160, 10 x 160, 12 x 160 mm in metal case	0,8		579817732
	<b>Twist drill bit pack DIN 338N sanded 1-13 mm HSS</b>	Twist drill set, profile grinding, 1-13mm increasing by 0,5 mm per drill bit	0,8		579817733
	<b>Bosch Professional SDS plus chisel Set 3 pieces 250 mm</b>	SDS-plus-chisel Set in Plastic bag, Content: Flat chisel 20 x 250 mm, Sharp chisel 250 mm, Spade chisel 40 x 250 mm	0,8		579817734
	<b>Round tin with bits, 10 pieces</b>	Small, practical set with magnetic 1/4" Universal holder and 9 bits.	0,3		579806858







## PULL- AND LIFTING EQUIPMENT

Product	Name	Description	Weight (kg)	Part no.
	<b>Support Quick- Lift, 600-1000 mm</b>	Max. Capacity: 55 kN, galvanised steel with patented, infinitely variable locking mechanism. Extended length: 600 - 1000 mm	8,2	579803137
	<b>Support Quick- Lift, 1000-1750 mm</b>	Max. Capacity: 55 kN, galvanised steel with patented, infinitely variable locking mechanism. Extended length: 1000 - 1750 mm	13,5	579803138
	<b>Support Quick- Lift, 1700-3100 mm</b>	Max. Capacity: 55 kN, galvanised steel with patented, infinitely variable locking mechanism. Extended length: 1700 - 3100 mm	16,5	579803139
	<b>Channel brace, 600-900 mm</b>	DIN 4124. Continuously adjustable. Steel tube shaft Ø 32 mm. Adjustment range: 600 - 900 mm. Capacity: 36 - 29 kN.	3,9	579803142
	<b>Channel brace, 800-1100 mm</b>	DIN 4124. Continuously adjustable. Steel tube shaft Ø 32 mm. Adjustment range: 800 - 1100 mm. Capacity: 34 - 29 kN.	4,6	579803141
	<b>Channel brace, 1100-1400 mm</b>	DIN 4124. Continuously adjustable. Steel tube shaft Ø 32 mm. Adjustment range: 1100 - 1400 mm. Capacity: 29 - 23 kN.	5,2	579803140
	<b>Shaped timbers according HLF load standard</b>	DIN 14530-11, stored in Firebox® according DIN 14880-1-LM-O-G.	23,7	579803125
	<b>Shaped timbers according RW load standard</b>	Shaped timbers according DIN 14555-3 (Rescue vehicle norm), stored in three Firebox® cases according DIN 14880-1-LM- O-G.	41,7	579803126
without image	<b>Wooden support set „Mün- chen“</b>	All timbers made from beech with chamfered edges and permanently visible markings.	0	579804315
	<b>Drive-over plank SL Hartwood</b>	DIN 14854, made from one piece.	10,5	579804620







## ROUND AND WEBBING SLINGS

Product	Name	Description	Weight (kg)	Part no.
	<b>Round sling RE 10, Circumference 2m, Working length 1m</b>	DIN EN 1492-2. Capacity 1000 kg. Single ply. Continuously laid strands, made from Polyester PES.	0,3	579802085
	<b>Round sling RE 10, Circumference 4m, Working length 2m</b>	DIN EN 1492-2. Capacity 1000 kg. Single ply. Continuously laid strands, made from Polyester PES.	0,5	579802086
	<b>Round sling RE 20, Circumference 4m, Working length 2m</b>	DIN EN 1492-2. Capacity 2000 kg. Single ply. Continuously laid strands, made from Polyester PES.	0,8	579802087
	<b>Round sling RE 20, Circumference 6m, Working length 3m</b>	DIN EN 1492-2. Capacity 2000 kg. Single ply. Continuously laid strands, made from Polyester PES.	1,55	579802088
	<b>Round sling RE 30, Circumference 4m, Working length 2m</b>	DIN EN 1492-2. Capacity 3000 kg. Single ply. Continuously laid strands, made from Polyester PES.	1,3	579802089
	<b>Round sling RE 30, Circumference 6m, Working length 3m</b>	DIN EN 1492-2. Capacity 3000 kg. Single ply. Continuously laid strands, made from Polyester PES.	2,45	579802090
	<b>Round sling RE 30, Circumference 8m, Working length 4m</b>	DIN EN 1492-2. Capacity 3000 kg. Single ply. Continuously laid strands, made from Polyester PES.	2,51	579802091
	<b>Round sling RE 40, Circumference 8m, Working length 4m</b>	DIN EN 1492-2. Capacity 4000 kg. Single ply. Continuously laid strands, made from Polyester PES.	3,2	579802080
	<b>Round sling RE 40 SS, Circumference 8m, Working length 4m</b>	DIN EN 1492-2. Capacity 4000 kg. Single ply, with edge protector. Continuously laid strands, made from Polyester PES.	3,9	579802081
	<b>Round sling RE 40, Circumference 10m, Working length 5m</b>	DIN EN 1492-2. Capacity 4000 kg. Single ply. Continuously laid strands, made from Polyester PES.	12,52	579806404
	<b>Round sling RE 60, Circumference 6m, Working length 3m</b>	DIN EN 1492-2. Capacity 6000 kg. Single ply. Continuously laid strands, made from Polyester PES.	4,45	579802092
	<b>Round sling RE 60, Circumference 8m, Working length 4m</b>	DIN EN 1492-2. Capacity 6000 kg. Single ply. Continuously laid strands, made from Polyester PES.	5,55	579802093
	<b>Round sling RE 80, Circumference 8m, Working length 4m</b>	DIN EN 1492-2. Capacity 8000 kg. Single ply. Continuously laid strands, made from Polyester PES.	6,25	579802094
	<b>Round sling RE 100, Circumference 6m, Working length 3m</b>	DIN EN 1492-2. Capacity 10000 kg. Single ply. Continuously laid strands, made from Polyester PES.	7,8	579802082
	<b>Round sling RE 100, Circumference 10m, Working length 5m</b>	DIN EN 1492-2. Capacity 10000 kg. Single ply. Continuously laid strands, made from Polyester PES.	12,52	579802083
	<b>Round sling RE 100, Circumference 10m, Working length 5m, SS</b>	DIN EN 1492-2. Capacity 10000 kg. Single ply. Continuously laid strands, made from Polyester PES, with edge protector	12,52	579806434
<b>Round sling RD 100, Circumference 20m, Working length 10m</b>	DIN EN 1492-2. Capacity 10000 kg. Continuously laid strands, made from Polyester PES. ->Only available as double ply!	12,52	579807121	



## ROUND AND WEBBING SLINGS

Product	Name	Description	Weight (kg)	Part no.
	<b>Lifting sling with loops, capacity 4000 kg, Length 8 m</b>	DIN EN 1492-1. Both ends with reinforced end loops. Sling width 120 mm, Loop width 450 mm. Capacity 4 t.	0	579804759
without image	<b>Protection hose for lifting sling, PVC</b>		3	579802084
	<b>Ribbon sling 80 cm / Ø 25mm, Protecta</b>	DIN EN 566:2017-05, DIN EN 795:2012-10 Type B, DIN EN 354:2010-11 Strength: >22 kN	0,1	579805059
	<b>Ribbon sling, 1,2 m</b>	Width 25mm, Tensile strength 2500 daN Norm similar EN 795 Kl. B	0,2	579807301
	<b>Ribbon sling 150 cm / Ø 25mm, Protecta</b>	DIN EN 566:2017-05, DIN EN 795:2012-10 Type B, DIN EN 354:2010-11 Strength: >20 kN	0,3	579805060
without image	<b>Ribbon sling, 1,8 m</b>		0,4	579807169

## LASHING STRAPS

Product	Name	Description	Weight (kg)	Part no.
	<b>Lashing strap with Ratchet, permissible Pulling force 800 daN, 8 m long, 1 piece</b>	prEN 12195-2 (VDI 2701-DIN 60060), GS-certified. without Hook	2,4	579805615
	<b>Lashing strap with Ratchet, permissible Pulling force 2000 daN, 6 m long, 2 pieces</b>	According prEN 12195-2 (VDI 2701 - DIN 60060). GS-certified. Strap width 50 mm. Fixed end 0,5 m long. Claw hooks.	2	579807142
	<b>Lashing strap with Ratchet, permissible Pulling force 2000 daN, 8 m long, 2 pieces</b>	According prEN 12195-2 (VDI 2701 - DIN 60060). GS-certified. Strap width 50 mm. Pointed hook two-strand.	2,4	579805846
	<b>Lashing strap with Ratchet, permissible Pulling force 3000 daN, 8 m long, 1 piece</b>	According prEN 12195-2 (VDI 2701 - DIN 60060). GS-certified. Strap width 50 mm. Ratchet short lever blade	2,4	579805845
	<b>Lashing strap with Ratchet, permissible Pulling force 3000 daN, 8 m long, 2 pieces</b>	With Pointed hook two-strand, prEN 12195-2 (VDI 2701-DIN 60060), GS-certified.	2,4	579806060
	<b>Lashing strap with Ratchet, permissible Pulling force 4000 daN, 8 m long, 1 piece</b>	According prEN 12195-2 (VDI 2701 - DIN 60060). GS-certified. Strap width 50 mm.	2,4	579805408
	<b>Lashing strap with Ratchet, permissible Pulling force 4000 daN, 10 m long, 2 pieces</b>	According prEN 12195-2 (VDI 2701 - DIN 60060). GS-certified. Strap width 50 mm, with pointed hook	2,6	579806948
without image	<b>Lashing strap with Ratchet, permissible Pulling force 5000 daN, 6 m long, 2 pieces</b>	With Pointed hook one-strand. Fixed end 0,5 m long. According prEN 12195-2 (VDI 2701 - DIN 60060), GS-certified.	2,3	579804614

## LASHING STRAPS

Product	Name	Description	Weight (kg)	Part no.
	<b>Lashing strap with Ratchet, permissible Pulling force 5000 daN, 9 m long, 2-tlg.</b>	With triangular hook. prEN 12195-2 (VDI 2701-DIN 60060), GS-certified.	2,6	579805076
without image	<b>Lashing strap with Ratchet, permissible Pulling force 5000 daN, 10 m long, 2-tlg.</b>	With Pointed hook two-strand, prEN 12195-2 (VDI 2701-DIN 60060), GS-certified.	2,6	579805454
	<b>Lashing strap with Ratchet, 50 mm, 5 m long</b>	Ratchet lashing strap to secure cargo. Max. Load capacity 2500 kg with claw	2,3	579803144







## SHACKLES

Product	Name	Description	Weight (kg)	Part no.
	<b>Shackle DIN 82101-A, Size 1, 1 t</b>	DIN 82101-A. Nominal size: 1. 1 t.	0,4	579803087
	<b>Shackle DIN 82101-A, Size 3, 3 t</b>	DIN 82101-A. Nominal size: 3. 3 t.	1,9	579803088
	<b>Shackle DIN 82101-A, Size 5, 5 t</b>	DIN 82101-A. Nominal size: 5. 5 t.	4	579803089
	<b>Shackle DIN 82101-C, Size 1, 6,5 t</b>	DIN 82101-C. Nominal size: 1,6. 5 t. High-strength.	0,8	579803090
	<b>Shackle similar DIN 82101-C, Size 3, 10 t, high-strength</b>	Bracket hot galvanised, screw electro galvanized.	2	579803091
	<b>Shackle DIN 82101-C, Size 5, 15 t</b>	DIN 82101-C. Nominal size 5. 15 t. High-strength.	4,4	579803092
	<b>Shackle DIN 82101 H, Size 1-1/8", 9,5 t</b>	DIN 82101 H, DIN 14555-T3. Nominal size 1-1/8". 9,5 t. Curved. High-strength.	3,2	579803093
	<b>Shackle DIN 82101 H, Size 1-1/4", 12 t</b>	DIN 82101 H, DIN 14555-T3. Nominal size 1-1/4". 12 t. Curved. High-strength.	4,6	579803094

## ADDITIONAL TOOLS









Product	Name	Description	Weight (kg)	Part no.
	<b>Deflection pulley 130 kN</b>	Pulling force 130 kN, suitable for Multipurpose hoist 50kN.	13	579803095
	<b>Gojak Vehicle scooter, 6313L</b>	Load capacity: 705 kg. Tyre width max.: 33 cm, left	17,5	579806447
	<b>Gojak Vehicle scooter, 6313R</b>	Load capacity: 705 kg. Tyre width max.: 33 cm, right	17,5	579806448
without image	<b>Hydraulic jack 12t.</b>		1,5	579807231
	<b>Exhaust hose 50 mm, 1,5 m</b>	DIN 14572:2016-07 Diameter 50 mm	2	579803097
	<b>Exhaust hose 50 mm, 2,5 m</b>	DIN 14572:2016-07 Diameter 50 mm	2,9	579806181
	<b>Exhaust hose 80 mm, 2,5 m</b>	DIN 14572:2016-07 Diameter 80 mm	3,6	579803332
	<b>Exhaust hose 102 mm, 2,5 m</b>	DIN 14572:2016-07 Diameter 102 mm	6,00	579804057
	<b>Exhaust hose 130 mm, 2,5 m</b>	DIN 14572:2016-07 Diameter 130 mm	6,8	579803338
	<b>Towing rope Polyamid, 4 t, 4 m long</b>	For vehicles up to 4 t, Diameter 20 mm	1,05	579804122
	<b>Towing rope Steel, 15 t, 5 m long</b>	DIN 76031, For vehicles up to 15 t, Diameter 16 mm	6	579803334
	<b>Lifting chain, 4 m</b>	Nominal thickness 13 mm. Load capacity >6500 kg.	22,4	579803096
without image	<b>Choker rope with fibre core</b>	Form B - SIKA-Hook - loop	0,3	579805472
	<b>Tow bar 16t, Steel, 1 piece, 1900 mm</b>	Standard with 40 mm hole on both sides.	15,5	579803345

## ADDITIONAL TOOLS

Product	Name	Description	Weight (kg)	Part no.
	<b>Chock G46 for LKW galvanized</b>	DIN 76051, for LKW, galvanized	3	579803333
without image	<b>Chock 480 Size 53</b>		3,9	579803340
	<b>Chock G 53/200 yellow</b>	DIN 76051, Plastic, Form G, Nominal size 53	1,84	579804565
without image	<b>Chock Size 1, Rotzler</b>	DIN 14584	13,9	579805473
	<b>Chock Dönges foldable</b>	similar DIN 14584 up to 50kN	13,8	579816052
	<b>Jumper cable 2x35mm<sup>2</sup>, 5 m</b>	(Twin wire) with 1 Plug and 2 callipers	5,2	579805629
	<b>Jumper cable 2x35 mm<sup>2</sup>, 6 m</b>	Twin wire, calliper on both ends	6	579806279
	<b>Jumper cable 50 mm<sup>2</sup>, 7 m long</b>	4 insulated callipers, however, WITHOUT protective circuit	6,8	579806437
	<b>Blow gun Dönges</b>	With plug, Working pressure 2-6 bar. To use with pressure hose.	0,3	579804449
	<b>Tire inflation gauge</b>	uncalibrated, 0 - 10 bar	1,04	579803348



## ADDITIONAL TOOLS

Product	Name	Description	Weight (kg)	Part no.
	<b>Tire inflation gauge RF-RM with manometer, calibrated</b>	Manometer display 0,7 - 7,0 bar. Hose length 0,41 m. Pressure max. 7 bar.	1	579804137
	<b>Spiral hose for Blow gun Dönges</b>	With Coupling and Socket 9,5 x 11,8 mm à 7,5m	1,2	579804450
without image	<b>Spiral hose for Blow gun Dönges</b>	With Coupling and Socket 9,5 x 11,8 mm à 5m	1,2	579807346
	<b>Earth anchor puller</b>	Height jack: 600 mm. Length Drawing iron: 1160 mm. Completely hot-dip galvanized finish.	10,8	579803131
	<b>Earth anchor Size 1</b>		18	579805075
	<b>Cramp iron, Type A</b>	DIN 7961. Type A: Pulling clamp.	0,7	579803152
	<b>Cramp iron, Type C</b>	DIN 7961. Type C: Composite clamp with two drill holes.	0,4	579803153
	<b>Threaded bolt set</b>	DIN 976:2016-09, with 5 threaded bolts each size: M 12x1000 mm, M 16x1000 mm, M 20x1000 mm	18,9	579803272
	<b>Washer set</b>	DIN EN ISO 7093-1, with 25 washers each M 5, M 6, M 8, M 10, M 12, M 16, M 20, galvanized	0,4	579803273
	<b>Hex nut set</b>	DIN EN ISO 4032, with 25 hex nuts each: M 12, M 16, M 20, galvanized	2,5	579803274







## ADDITIONAL TOOLS

Product	Name	Description	Weight (kg)	Part no.
	<b>Coarse thread screw set</b>	With countersunk head, PZ Philips screws, galvanized. With 100 screws each size: 4,5x45 mm, 5x60 mm, 6x80 mm, 8x100 mm	2,6	579803275
	<b>Wood screw set</b>	DIN 571, with 25 wood screws each: 5 x 90, 6 x 100, 8 x 120, galvanized	4,1	579803276
	<b>Frame anchor set</b>	with 100 anchors 6 x 30 mm, 100 Anchors 8 x 40 mm, 50 Anchors 10 x 50 mm, 40 Anchors 12 x 60 mm	0,65	579803277
	<b>Perforated plate set</b>	Consists of 5 plates straight 100x200x2 mm, 5 90° Angles 90x90x2,5 mm, 5 90° Angles 100x100x3 mm, 4 joist hangers 100x140 mm, outside flaps	0,8	579803279
	<b>Disc dowel set</b>	DIN EN 912, with 10 Piece each Ø 80 mm and Ø 95 mm	0,2	579803280
	<b>Ribbed nails</b>	galvanized, 4 x 60 mm, Package incl. 100 Pieces	0,1	579803278





## ADDITIONAL TOOLS

Product	Name	Description	Weight (kg)	Part no.
	<b>Canister - Steel sheet, 5 l, Fuel, unfilled, olive green</b>	Military design, stackable, UN certified, to transport dangerous good according GGVS.	2,2	579804612
	<b>Canister - Steel sheet, 5 l, Fuel, unfilled, red</b>	Military design, stackable, UN certified, to transport dangerous good according GGVS.		579806239
	<b>Canister - Steel sheet, 10 l, Fuel, unfilled, olive green</b>	Military design, stackable, UN certified, to transport dangerous good according GGVS. TÜV & GS certificate.	3	579803342
	<b>Canister - Steel sheet, 10 l, Fuel, unfilled, yellow</b>	Military design, stackable, UN certified, to transport dangerous good according GGVS. TÜV & GS certificate. Stove-enamelled.		579805564
	<b>Canister - Steel sheet, 20 l, Fuel, unfilled, olive green</b>	Military design, stackable, UN certified, to transport dangerous good according GGVS. TÜV & GS certificate. Stove-enamelled.	4,5	579803124
	<b>Canister - Steel sheet, 20 l, Fuel, unfilled, yellow</b>	Military design, stackable, UN certified, to transport dangerous good according GGVS. TÜV & GS certificate. Stove-enamelled.		579804725
	<b>Canister - Steel sheet, 20 l, Fuel, unfilled, red</b>	Military design, stackable, UN certified, to transport dangerous good according GGVS. TÜV & GS certificate. Stove-enamelled.		579805182
	<b>Canister - Plastic, 5 l, unfilled</b>	With GGVS certification, including spout.	0,5	579803341
	<b>Canister - Plastic, 10 l, Fuel, unfilled, black</b>	GGVS certification. Incl. outlet pipe and undetachable child safety lock. E10 suitable.	0,56	579805455
	<b>Dönges Automatic spout Smart-Spout</b>	The automatic spout detects when the tank is full and stops the fuel flow automatically. Half-full tanks or the dangerous spilling of highly flammable fuel are now a thing of the past. The Smart-Spout fits on the Dönges sheet steel petrol canisters with 5 l and 10 l volume.	0,26	579808789
	<b>Spout, flexible</b>	For Steel sheet canister, galvanized, with air hole.	0,26	579803344

## ADDITIONAL TOOLS

Product	Name	Description	Weight (kg)	Part no.
	<b>Emergency pump</b>	Effective to transfer e.g., fuel, water, and oil-containing substances.	0,3	579803123
	<b>Sand ladder, aluminium</b>	DIN 14555-T3. To drive on loose soil or for extracting a stuck vehicle. Also perfect for ice, snow, and mud.	4	579803145
	<b>Basin, stainless steel</b>	similar DIN 14060, with two folding handles, stackable	3,4	579807063
	<b>Binding rope made of hemp, 2 m</b>	eye splice at one end. Diameter 8 mm.	0,2	579803073
	<b>Lifting harness for horse and cattle</b>	Mattress 1000x800 mm with trapezoidal fixing mechanism 800x500 mm on both narrow sides, Webbing 50 mm wide with length-adjustable loops.	4,8	579804761
	<b>Transport roller</b>	DIN 14555, For putting beneath and moving even extremely heavy loads. Made from hot-galvanised tubular steel, wall thickness 5 mm, Diameter: 80 mm	9,1	579803154
	<b>Fabric adhesive tape G76</b>	Polyethylene fabric coating. Natural rubber adhesive. Weather and aging resistant. Covering rough surfaces, such as plaster, repair tape, sealing, fixing. Core diameter 75 mm.	0,3	579803159

## ADDITIONAL TOOLS

Product	Name	Description	Weight (kg)	Part no.
	<b>Mobile measuring device ALF</b>	With the help of ALF, you can determine the suitable location of your turntable ladder within seconds! Unlike a conventional laser rangefinder, ALF indicates whether you need to approach or move away from the object. Compatible with all 50m turntable ladders, Compatible with Hydraulic platforms up to 50m, Support for articulated arms, No adjustment to the turntable ladder required. Specifically made for your vehicle. Intuitive Interface. Made for outdoor usage		579808127
	<b>USB Charger ALF</b>		0,2	579808128
	<b>Protection cover ALF</b>		0,2	579808130
	<b>Vehicle mount ALF</b>		0,3	579808129
	<b>Zipper for ALF</b>		0,1	579808131
	<b>Laser measure Bosch GLM 120 C Professional</b>	The digital viewfinder allows for visual targeting in outdoor applications for distances up to 120 meters. Optimal clarity and durability are provided by the 2.8" colour display with a protective screen.	0,3	579808806

**SNOW CHAINS**

Product	Name	Description	Weight (kg)	Part no.
	<b>Snow chain RUD- matic Classic V</b>	for Tyre size 225/75 R 16	10	579805546
		for Tyre size 225/75 R 17,5	10	579804636
		for Tyre size 275/80 R 22,5	10	579806607
		for Tyre size 285/70 R 19,5 and 285/85 R 16,5	10	579804694
		for Tyre size 285/70-R22,5	10	579808019
		for Tyre size 305/70 R 22,5	10	579806667
	<b>Snow chain RUD- matic MAXI</b>	for Tyre size 275/70 R 22,5	10	579805227
		for Tyre size 315/80 R22,5	10	579804997
		for Tyre size 385/55 R 22,5	10	579805226
		for Tyre size 385/65 R 22,5	10	579804086
		for Tyre size 11 R22,5	10	579806506

More sizes upon request.

## ONE-PERSON HOSE REELS

Product	Name	Description	Weight (kg)	Colour	Part no.
	<b>One-person hose reel Hose Barth</b>	DIN 14826-2, Standard model, Outer width 967mm to accommodate max. 160m Storz-B hoses, crank handle right	55	red	579805003
	<b>One-person hose reel Hose</b>	DIN 14826-2, Standard model, Outer width 967mm to accommodate max. 160m Storz-B hoses, crank handle left	55	red	579805139
	<b>One-person hose reel Hose, bright red RAL 3024</b>	DIN 14826-2, Standard model, Outer width 967mm to accommodate max. 160m Storz-B hoses, crank handle custom-izable	55	bright red	579802767
	<b>One-person hose reel Hose Barth, RAL 9010</b>	DIN 14826-2, Standard model, Outer width 967mm to accommodate max. 160m Storz-B hoses, crank handle right	55	pure white	579805667
	<b>One-person hose reel Hose Barth, narrow</b>	Narrow model, Outer width 757mm to accommodate max. 100m Storz-B hoses, crank handle left	55	red	579802768
	<b>One-person hose reel Hose Barth, narrow</b>	Narrow model, Outer width 757mm to accommodate max. 100m Storz-B hoses, crank handle right	55	red	579805235
	<b>One-person hose reel Barth Stand pipe</b>	Outer width 967mm to accommodate 6 x B-20 hoses, stand pipe mount fixed to the right of hose reel.	65		579816485
	<b>Stand pipe storage Barth One-person hose reel, for assembly</b>	To store stand pipe DIN 14375-2B, Wrench C DIN 3223, Wrench B DIN 3223, Coupling wrench B/C	9		579802770
	<b>Stand pipe storage for Barth one-person hose reel narrow</b>	To store stand pipe DIN 14375-2B, Wrench C DIN 3223, Wrench B DIN 3223, Coupling wrench B/C	7,5		579802771
	<b>Stand pipe storage Württemberg</b>	To store stand pipe DIN 14375, Wrench B DIN 3223, Wrench C Württemberg, Standpipe extension, manhole cover lift & Coupling wrench BC	9		579802772

## ONE-PERSON HOSE REELS HOSE

Product	Name	Description	Weight (kg)	Colour	Part no.
	<b>Storage box for system divider AWG Type B-FW</b>	To secure at handle of hose reel, with foldable lid.	1		579807931
	<b>Storage box for system divider Schott Type B-FW F2</b>	To secure at handle of hose reel, with foldable lid.	1		579808359
	<b>Storage box for system divider B-FW RESIDIO</b>	To secure at both handles of hose reel, with foldable lid.	3,2		579809520
	<b>Cover for Barth One-person hose reel</b>		1		579802773
	<b>Cover for One-person hose reel narrow</b>		0,8		579802774
	<b>Storage for roofing hammer on stand pipe storage EPH</b>	Only in connection with stand pipe storage 579802770	0,9		579804885
without image	<b>Replacement crank handle for one-person hose reel</b>		1		579804777
	<b>Roll-up warning sign for one-person hose reel</b>	Without Stand pipe storage, to mount on crossbeam of one-person hose reel via fixing plate made of stainless steel.	2		579804886
	<b>Roll-up warning sign for one-person hose reel</b>	Without Stand pipe storage, to mount on crossbeam of one-person hose reel via fixing plate made of stainless steel.	2		579806301
	<b>Roll-up warning sign for one-person hose reel Hose narrow</b>	Starting construction year 2005, suitable for models with or without stand pipe holder.	2		579806775



## ONE-PERSON REELS TRAFFIC-SAFETY

Product	Name	Description	Weight (kg)	Colour	Part no.
	<b>One-person reel Barth Traffic foldable cones</b>	<p>Carries equipment for traffic safety on highways and motorways.</p> <p>Storage container made of anodized aluminium incl. lid for 3 foldable signs 900 mm (up to 1250 mm packed length) and 14 Foldable cones 750 mm, Storage of foldable cones in robust holder. Delivery without equipment.</p> <p>Mirrored setup required for certain vehicle types so tail lights are not covered by storage container for foldable signs. The required setup needs to be checked with the vehicle manufacturer beforehand.</p>	83		579817736
	<b>One-person reel Barth Traffic foldable cones, mirrored</b>	Setup mirrored - foldable cones right, foldable signs left	83		579817739
	<b>One-person reel Barth Traffic Plus foldable cone</b>	<p>Storage container made of anodized aluminium incl. lid for 3 foldable signs 900 mm (up to 1250 mm packed length) and 13 Foldable cones 750 mm, Storage of foldable cones in robust holder.</p> <p>Rear-mounted storage container made of anodized aluminium for 4 to 6 Euro flash lights, charger set in the storage container for the Euro flash lights. Console fitted with 3 yellow flash lights Ø 185 mm, pivotable, can be pointed ahead or behind. Power supply for flash lights via energy box (included in scope of delivery). Battery charging through vehicle via connection cable (2-pin MagCode plug). Delivery without equipment.</p> <p>Mirrored setup required for certain vehicle types so tail lights are not covered by storage container for foldable signs. The required setup needs to be checked with the vehicle manufacturer beforehand.</p>	96		579817737
	<b>One-person reel Barth Traffic Plus foldable cone - mirrored</b>	Setup mirrored - Foldable cones right, foldable signs left	96		579817738



## TRAFFIC-SAFETY CARRIERS

Product	Name	Description	Weight (kg)	Colour	Part no.
	<b>One-person reel Barth Traffic model 2015</b>	Storage space for 3 Folding signs 900mm, 10 Traffic cones 750mm, optional storage container for pin lamp and flash lights available	83	red	579804838
	<b>One-person reel Barth Traffic Plus model 2015</b>	Space to store equipment for traffic safety on highways, with energy box and connection cable (MagCode plug)	83	red	579806620
	<b>One-person reel Barth Traffic Narrow model 2015</b>	Storage space for 10 traffic cones 750mm and storage container for 3 flash lights.	70	red	579805919
	<b>Storage container incl. lid Barth One-person reel Traffic model 2015</b>	Space to store equipment for traffic safety such as: 4 flash lights Euro-Blitz or 6 flash lights Euro-Blitz Compact.	9,5		579804839
without image	<b>Charger Barth EPH Traffic 2015</b>	To charge 4 Euro-Blitz in storage container. To install in storage container.	0,18		579805189
	<b>Pin flash light mount DUO Barth</b>	Mount made of aluminium plate for 2 pin flash lights for one-person carrier Traffic 2015. Mounted on carrier handle.	0,5		579804841
	<b>Pin flash light mount Barth two-fold</b>	Mount made of aluminium plate for 2 pin flash lights for one-person carrier Traffic 2015. Mounted on carrier handle.	1		579804842
	<b>Electricity connector one-person reel Barth</b>	To automatically create charging contact when carrier is joined with vehicle.	1		579804843
	<b>Electricity connector for mounting arm Barth</b>	To automatically create charging contact when carrier is joined with vehicle.	0,18		579804844

## ONE-PERSON REELS

Product	Name	Description	Weight (kg)	Colour	Part no.
without image	<b>Supplement charging set Barth EPH Signal for 6 x Euro-Blitz</b>	To install in storage container.	9		579805710
	<b>Supplement charging set for 6 lights Euro- Blitz Compact</b>	for one-person carrier Traffic and Traffic PLUS	0,18		579806236
	<b>Supplement charging connection via 6-pin ROPD plug</b>	Accessories for one-person carrier TRAFFIC Modell 2015	0		579806707
	<b>One-person reel Barth Equipment carrier</b>	With one storage container to transport various equipment pieces	57,5		579804524
	<b>Cover for One-person reel Barth Equipment carrier</b>	With lock.	1		579804525
	<b>Lid for one-person reel Barth Equipment carrier</b>	Front part can be opened via hinge.	1		579815242
	<b>One-person hose reel Barth WALDBRAND</b>	To transport equipment for forest firefighting missions. Delivery without equipment. Container made from aluminium with lockable lid to store 2 extinguishing backpacks and 2 backpack modules (WxH) 530x760 mm, extraction slot 530x430 mm. Backpacks secured via 2 fixed lashing rails. Storage space left and right side of container to contain 2 fire swatters Vallfirest Alaska and 2 forest fire tools Vallfirest Gorgui V2, secured via tape. Storage in anthracite colour RAL 7016, Weight with equipment approx. 130 kg.	66		579816084

## ONE-PERSON HOSE REELS

Product	Name	Description	Weight (kg)	Colour	Part no.
 	<b>Colour rings for wheel rims one-person hose reel</b>	1 pair	0,1	white reflective	579802778
	<b>Colour rings for wheel rims one-person hose reel</b>	1 pair	0,1	bright red fluorescent	579802779
	<b>Colour rings for wheel rims one-person hose reel</b>	1 pair	0,1	Saturn yellow fluorescent	579802780
	<b>Colour rings for wheel rims one-person hose reel</b>	1 pair	0,1	red reflective	579804884
	<b>Colour rings for reel disc one-person hose reel</b>	1 pair	0,1	white reflective	579802775
	<b>Colour rings for reel disc one-person hose reel</b>	1 pair	0,1	bright red reflective	579802776
	<b>Colour rings for reel disc one-person hose reel</b>	1 pair	0,1	Saturn yellow, fluorescent	579802777
	<b>Colour rings for reel disc one-person hose reel</b>	1 pair	0,1	red reflective	579804883

## ROLL CONTAINERS

Product	Name	Description	Weight (kg)	Part no.
	<b>Roll container Universal</b>	Measurements 1200 x 800 x 1200 mm Height to Upper edge Platform 293 mm	46	579801718
	<b>Roll container Universal with 2 platforms, low</b>	Height to Upper edge Platform: 843 mm	70	579801719
	<b>Roll container Universal with 2 platforms, high</b>	Height to Upper edge Platform: 838 mm	70	579801720
	<b>Roll container for Hose, sinuate</b>	for 500 m B-Hose, sinuate in 5 bays. Base plates & Walls PE plates, Upper edge Setup 1060 mm	105	579801721
	<b>Roll container for Hose, rolled</b>	for 540 m B hoses, twice rolled. Setup for 15 Hoses à 20m, 2 containers for 6 Hoses à 20m removable, Upper edge Setup without Box 870 mm	140	579801727
	<b>Roll container for Power-Light</b>	Setup with mounts for: - Working lights - Tripod - Generator - Cable reel - Fuel canister	80	579801722
	<b>Roll container for respirators</b>	For safe and protected storage of 6 respirators with masks in dust & shock-protected environment.	132	579801723
	<b>Roll container for respirators</b>	To store 6 respirators with masks (one-bottled device) incl. Masks and 6 replacement breathing air bottles (6 l Steel or 6,8 l CFK).	148	579801729

## ROLL CONTAINERS

Product	Name	Description	Weight (kg)	Part no.
	<b>Roll container for Breathing air bottles</b>	For safe and space-saving transport of 24 breathing air bottles (6l or 6,8l CFK – bottle measurements up to (ØxH) 170x700 mm)	119	579801724
	<b>Roll container for Portable pump and Accessories, GZ Steig-technik</b>	Setup with mount for portable pump PFPN 10-1000/10-1500 and suction-side Accessories	110	579801725
	<b>Roll container Flood</b>	To store various equipment pieces to fight floods.	46	579804704
	<b>Roll container Universal with lattice box, low</b>	Setup with lattice walls (galvanized), wall on right side foldable at half height. Upper edge Lattice box 825 mm, Fill height 530 mm	96	579801726
	<b>Roll container Universal with lattice box, high</b>	Setup with Lattice box, wall on right side foldable at half height. Upper edge Lattice box 1200 mm, Fill height 888 mm	116	579804705
	<b>Roll container Universal with aluminium box</b>	Aluminium setup with closed basin in lower part. Fill height for liquids 200mm, fill capacity around 180l. wall on right side foldable at half height Upper edge Aluminium box 825 mm, Fill height 525 mm	80	579801728



 Made in Germany

# THE MOBILE HYGIENE STATION

Deployment hygiene everywhere, anytime. Without electricity, without batteries.

The mobile and handy hygiene and disinfection tool helps to thoroughly clean hands and protect health during every use. It impresses with its independence from electricity or batteries as well as its easy handling. With a fresh water supply, it allows up to 25 hand washes.

- Pressure pump Without electricity, without battery
- Overpressure valve
- Practical holders for soap and hand sanitizer dispensers
- HDPE container, robust and recyclable
- Lockable drain plug, leak-proof
- Opening for emptying the wastewater container (IBC-S60 container connection)
- Filling connection with 1/2" connection, e.g., for commercially available hose connectors
- Filling connection for fresh water, easy filling
- Shoulder strap, easy to carry
- Freshwater tank, maximum capacity of 8.5 litres, up to 25 hand washes
- Separable containers, easy handling when filling and emptying
- Collection container for dirty water (capacity 9 litres), environmentally friendly
- Operating temperature range: 5 - 40 °C
- Empty weight (without dispenser) approximately 3.6 kg
- Maximum weight with full freshwater tank (without dispenser) approximately 12.1 kg
- Water faucet and connection fittings made of stainless steel
- Container material is HDPE

#### ADDITIONAL EQUIPMENT FEATURES:

- Tank system with manual pressure pump and riser
- Measurements approx. 39 x 39 x 55 cm (W/D/H)
- Maximum capacity (freshwater/wastewater tank) 8.5 L / 9 L
- Maximum pressure (freshwater/wastewater tank) 1 bar / 0.5 bar

Part no. 579816535

## MOBILE HYGIENE STATION

Product	Name	Description	Content	Part no.
<b>ACCESSORIES MOBILE HYGIENE STATION</b>				
	<b>Hand soap</b>	Special soap for washing hands. Cleanses pores thoroughly. Kind to skin.	4 x 250 ml	579816640
	<b>Hand disinfectant</b>	Alcohol-based hand disinfectant. Nourishes and re moisturizes the skin.	4 x 250 ml	579816641
	<b>Hand and shower head Set</b>	Expansion of mobile hygiene station.		579816644
	<b>Tank cleaning</b>	To clean drinking water tanks	250 g powder	579816643
	<b>Water conservation</b>	Practical and simple water conservation. Ideal to treat water while traveling or out and about.	40 tabs	579816642
	<b>Foldable wall bracket LAVconnect</b>	with straps for fixation and optimized for single use storage container		579819488
without image	<b>Ladder hook for LAV-Connect and LAVConnect Plus</b>	to attach the LAVConnect (Plus) to the ladder rung		579819490
	<b>Skin Cleaning Gel pak-ex 50 ml</b>	2 in 1 Cleaning gel (for coarse and complete decontamination) for effective hand cleaning after firefighting deployments. Suitable for mobile hygiene stations.	50 ml	579819743
	<b>Skin Cleaning Gel pak-ex 200 ml</b>		200 ml	579819744
	<b>Skin Cleaning Gel pak-ex 250 ml</b>		250 ml	579818485
	<b>Skin Cleaning Gel pak-ex 500 ml</b>		500 ml	579819745

TECHNICAL EQUIPMENT



# RESPIRATORY PROTECTION









## SCBA SYSTEMS

Product	Name	Description	Weight (kg)	Part no.
	<b>SCBA system PSS@ AirBoss Active, Universal cylinder strap, BP</b>	DIN EN 137:2007-01 Type 2, PSA-Kat. III, Basic device with Manometer, Universal cylinder strap for single and twin cylinders and height adjustment, shoulder & waist belt with quick connect option.	3,9	579816184
	<b>SCBA system PSS@ AirBoss Active, Universal cylinder strap, BP</b>	DIN EN 137:2007-01 Type 2, PSA-Kat. III, Basic device with Manometer, Universal cylinder strap for single and twin cylinders and height adjustment, shoulder & waist belt with quick connect option.	3,9	579816186
	<b>SCBA system PSS@ AirBoss Active, Universal cylinder strap, GBS</b>	DIN EN 137:2007-01 Type 2, PSA-Kat. III, Basic device with Manometer, Universal cylinder strap for single and twin cylinders and height adjustment, shoulder & waist belt with quick connect option.	3,9	579816187
	<b>SCBA system PSS@ AirBoss Active, Universal cylinder strap, GBS</b>	DIN EN 137:2007-01 Type 2, PSA-Kat. III, Basic device with Manometer, Universal cylinder strap for single and twin cylinders and height adjustment, shoulder & waist belt with quick connect option.	3,9	579816188
	<b>SCBA system PSS@ AirBoss Active, Universal cylinder strap, BP</b>	DIN EN 137:2007-01 Type 2, PSA-Kat. III, Basic device with Manometer, durable space frame and universal cylinder strap for single and twin cylinders and height adjustment, shoulder & waist belt with quick connect option.	3,9	579816189
	<b>SCBA system PSS@ AirBoss Active, Universal cylinder strap, BP</b>	DIN EN 137:2007-01 Type 2, PSA-Kat. III, Basic device with Manometer, durable space frame and universal cylinder strap for single and twin cylinders and height adjustment, shoulder & waist belt with quick connect option.	3,9	579816190
	<b>SCBA system PSS@ AirBoss Active, Universal cylinder strap, SB</b>	DIN EN 137:2007-01 Type 2, PSA-Kat. III, Basic device with Manometer, Universal cylinder strap for single and twin cylinders and height adjustment, safety belt, shoulder & waist belt with quick connect option.	3,9	579816191
	<b>SCBA system PSS@ AirBoss Active, Universal cylinder strap, SB</b>	DIN EN 137:2007-01 Type 2, PSA-Kat. III, Basic device with Manometer, Universal cylinder strap for single and twin cylinders and height adjustment, safety belt, shoulder & waist belt with quick connect option.	3,9	579816192
	<b>SCBA system PSS@ AirBoss Active, Universal cylinder strap, SB</b>	DIN EN 137:2007-01 Type 2, PSA-Kat. III, Basic device with Manometer, durable space frame and universal cylinder strap for single and twin cylinders and height adjustment, safety belt, shoulder & waist belt with quick connect option.	3,9	579816193
	<b>SCBA system PSS@ AirBoss Active, Universal cylinder strap, SB</b>	DIN EN 137:2007-01 Type 2, PSA-Kat. III, Basic device with Manometer, durable space frame and universal cylinder strap for single and twin cylinders, safety belt	3,9	579816194

## SCBA SYSTEMS

Product	Name	Description	Weight (kg)	Part no.
	<b>SCBA system PSS@ AirBoss Agile, Universal cylinder strap, BP</b>	DIN EN 137 Type 2, PSA-Kat. III, Manometer with built-in radio for data transmission, universal cylinder strap for single and twin cylinders and height adjustment, shoulder & waist belt with quick connect option	3,9	579816195
	<b>SCBA system PSS@ AirBoss Agile, Universal cylinder strap, BP</b>	DIN EN 137 Type 2, PSA-Kat. III, Manometer with built-in radio for data transmission, universal cylinder strap for single and twin cylinders and height adjustment, shoulder & waist belt with quick connect option	3,9	579816196
	<b>SCBA system PSS@ AirBoss Agile, Universal cylinder strap, GBS</b>	DIN EN 137 Type 2, PSA-Kat. III, Manometer with built-in radio for data transmission, universal cylinder strap for single and twin cylinders and height adjustment, shoulder & waist belt with quick connect & different routing options	3,9	579816197
	<b>SCBA system PSS@ AirBoss Agile, Universal cylinder strap, GBS</b>	DIN EN 137 Type 2, PSA-Kat. III, Manometer with built-in radio for data transmission, universal cylinder strap for single and twin cylinders and height adjustment, shoulder & waist belt with quick connect & different routing options	3,9	579816198
	<b>SCBA system PSS@ AirBoss Agile Universal cylinder strap, BP</b>	DIN EN 137 Type 2, PSA-Kat. III, Manometer with built-in radio for data transmission, universal cylinder strap for single and twin cylinders and height adjustment, shoulder & waist belt with quick connect & different routing options	3,9	579816199
	<b>SCBA system PSS@ AirBoss Agile, Universal cylinder strap, BP</b>	DIN EN 137 Type 2, PSA-Kat. III, Manometer with built-in radio for data transmission, universal cylinder strap for single and twin cylinders and height adjustment, shoulder & waist belt with quick connect option	3,9	579816200



## SCBA SYSTEMS

Product	Name	Description	Weight (kg)	Part no.
	<b>SCBA system PSS 3000 (EU) Komfort</b>	Authorisation EN 137 2006 Type 2. With Space frame.	3,36	579801443
	<b>SCBA system PSS 4000</b>	EN 137 2006 Type 2, vřdb 0802, with space frame & manometer, 1 cylinder device	3	579805374
	<b>SCBA system Dräger PSS 5000 DP Manometer / Universal cylinder strap</b>	DIN EN 137 Type 2, vřdb 0802, Basic device with Manometer, stainless steel buckles, 1 cylinder device	4,15	579801448
	<b>SCBA system Dräger PSS 5000 DP Manometer / Universal cylinder strap</b>	DIN EN 137 Type 2, vřdb 0802, Basic device with Manometer, stainless steel buckles, universal cylinder strap for 1 or 2 cylinders	4,64	579801449
	<b>SCBA system PSS 5000 DP, BG 7000, Universal cylinder strap</b>	DIN EN 137 Type 2, vřdb 0802, Basic device with Manometer, stainless steel buckles, 1 cylinder device, incl. Bodyguard 7000	4,42	579801450
	<b>SCBA system PSS 5000 DP, BG 7000, Universal cylinder strap</b>	DIN EN 137 Type 2, vřdb 0802, Basic device with Manometer, stainless steel buckles, universal cylinder strap for 1 or 2 cylinders, incl. Bodyguard 7000	4,5	579801451

## ACCESSORIES SCBA SYSTEMS

Product	Name	Description	Weight (kg)	Part no.
	<b>Dräger PSS Safety Belt Upgrade set for Dräger PSS 5000 DS</b>	New kit to upgrade the Dräger PSS 5000 DS to PSS 5000 DP with an integrated PSS Safety Belt.	4,6	579805354
	<b>Safety Belt PSS 5000 Upgrade set for Dräger PSS 5000 DP</b>	Designed for easy integration into Dräger PSS 5000.		579805352
	<b>Dräger PSS Safety Belt Upgrade set for Dräger PSS 7000</b>	Designed for easy integration into Dräger PSS 7000.		579805353
   	<b>Lanyard for 2<sup>nd</sup> airline, PSS 3000</b>	Secondary supply hose for SCBA system LF, PSS 3000	0,324	579801460
	<b>Lanyard for 2<sup>nd</sup> airline for Waist belt, PSS 5000/7000</b>	Secondary supply hose for SCBA system PSS 5000/ PSS 7000	0,342	579801456
	<b>Lanyard for 2<sup>nd</sup> airline, right Shoulder, PSS 5000</b>	Secondary supply hose for SCBA system PSS 5000	0,452	579801458
	<b>Lanyard for 2<sup>nd</sup> airline, left Shoulder, PSS 5000</b>	Secondary supply hose for SCBA system PSS 5000 with Low-Force-Coupling	0,468	579801459
	<b>Motionless detector Bodyguard 1000 with Button</b>	Designed to protect life by alerting the team when a wearer becomes motionless or distressed, it emits clear and distinctive signals and alarms to ensure quick and effective recognition.	0,324	579801463
	<b>Motionless detector Bodyguard 1000 with Activation key</b>		0,336	579801464
	<b>Motionless detector Bodyguard 1000 with Button/ Activation key</b>		0,336	579801465
	<b>Motionless detector Bodyguard 1500 Button</b>	DIN EN 137 Type 2, automatic wireless system which increases wearer safety in potentially hazardous situations. The system draws attention to colleagues in distress by generating distinctive visual and acoustic alert signals. Activated through button.	0,23	579816201





## ACCESSORIES SCBA SYSTEMS

Product	Name	Description	Weight (kg)	Part no.
	<b>Motionless detector Bodyguard 1500 Button/Key</b>	DIN EN 137 Type 2, automatic wireless system which increases wearer safety in potentially hazardous situations. The system draws attention to colleagues in distress by generating distinctive visual and acoustic alert signals. Activated through button or key.	0,23	579816202
without image	<b>TX Manometer (without Combination line)</b>			579816203
	<b>Combination line (Manometer line)</b>		0,7	579806730
	<b>Lung Demand Valve Dräger PSS-N</b>	Suitable for all Dräger PSS devices. RA thread connection RD 40, with short hose	0,5	579801466
	<b>Lung Demand Valve Dräger PSS-ESA</b>	Suitable for all Dräger PSS devices, with universal thread connection, including Lung Demand Valve holder	0,472	579801467
	<b>Lung Demand Valve PSS-A</b>	Suitable for all Dräger PSS devices, with DRÄGER PE thread connection, with short hose	0,396	579801468
	<b>Lung Demand Valve DrägerMan PSS-AE</b>	Suitable for all Dräger PSS devices, with PE thread connection M 45x3	0,52	579801469
	<b>Lung Demand Valve PSS-N</b>	Suitable for all Dräger PSS devices. RA thread connection RD 40, with long hose	0,66	579801470
	<b>Lung Demand Valve holder N/ESA</b>	For Lung Demand Valve holder with RA thread connection or PE thread connection according DIN 58600.	0,056	579801471
	<b>Lung Demand Valve holder A</b>	For Lung Demand Valve holder with RA thread connection or PE thread connection according DIN 58600.	0,06	579801472
	<b>Lung Demand Valve holder AE</b>	For Lung Demand Valve holder with RA thread connection or PE thread connection according DIN 58600.	0,04	579801473

## RESPIRATORY MASKS

Product	Name	Description	Weight (kg)	Part no.
<b>RESPIRATORY MASK DRÄGER PANORAMA NOVA</b>				
The full-face mask represents absolute reliability in the protection of the respiratory tract and eyes. Combined with appropriate filters, airline systems or self-contained breathing apparatus, the mask is a reliable and safe system.				
	<b>Respiratory mask Dräger Panorama Nova RA-EPDM-PC</b>	Full-face mask with RA thread connection RD40, visor made of PC, with Neck strap	0,9	579801474
	<b>Respiratory mask Panorama Nova PE-EPDM-PC</b>	Full-face mask with PE thread connection M45x3, visor made of PC, with Neck strap	0,74	579801475
	<b>Respiratory mask Dräger Panorama Nova ESA-EPDM-PC</b>	Full-face mask with universal thread connection with integrated RA thread connection, visor made of PC, with Neck strap	0,742	579801476
	<b>Respiratory mask Panorama Nova P-EPDM-PC</b>	Full-face mask with PE thread connection, visor made of PC, with neck strap	0,88	579801477
	<b>Respiratory mask Dräger FPS 7000 RA-EPDM-M2-PC-EPDM</b>	Full-face mask according DIN EN 136-04 Cl. 3, Neck strap Size M, Interior mask Size 2 (other sizes upon request), visor made of PC, RA thread connection RD40	1,18	579801478
	<b>Respiratory mask FPS 7000 PE-EPDM-M2-PC</b>	Full-face mask according DIN EN 136-04 Cl. 3, Neck strap Size M, Interior mask Size 2 (other sizes upon request), visor made of PC, PE thread connection M45x3	1,19	579801479
	<b>Respiratory mask Dräger FPS 7000 ESA-EPDM-M2-PC-CR</b>	Full-face mask according DIN EN 136-04 Cl. 3, Neck strap Size M, Interior mask Size 2 (other sizes upon request), visor made of PC, Universal thread connection with integrated RA thread connection	1,91	579801480
	<b>Respiratory mask FPS 7000 P-EPDM-M2-PC-CR</b>	Full-face mask according DIN EN 136-04 Cl. 3, Neck strap Size M, Interior mask Size 2 (other sizes upon request), visor made of PC, DRÄGER PE thread connection	1,16	579801481

## ACCESSORIES RESPIRATORY MASKS

Product	Name	Description	Weight (kg)	Part no.
	<b>Combination filter 1140</b> <b>Dräger A2 B2 E2 K2 Hg</b> <b>P3 R D, RD 40</b>	EN 148-1 Protects against many hazardous substances – from phosphine to tear gas to particulates.	0,44	579801482
	<b>Combination filter 1140</b> <b>Dräger A2 B2 E2 K2 Hg</b> <b>P3 R D, M45x3</b>	EN 148-3. Protects against many hazardous substances – from phosphine to tear gas to particulates. PE thread connection M45x3	0,438	579801483
	<b>Carrying box Dräger</b> <b>WIKOV 5</b>	for Panorama Nova, adjustable strap, oval	0,59	579801487
	<b>Carrying box</b> <b>MABOX 1</b>	For Mask F2, FPS 7000 or Panorama Nova Supra with Filter, adjustable strap.	0,704	579801488
	<b>Carrying box</b> <b>MABOX 2</b>	For Masks F2, FPS 7000, small Size, with adjustable strap	0,62	579801489
	<b>Carrying box FPS-Box</b> <b>- Dräger</b>	For Mask FPS 7000, adjustable strap.	0,7	579801490





## COMPRESSED-AIR CYLINDERS

Product	Name	Description	Weight (kg)	Part no.
	<b>Compressed-air cylinder Dräger 6,8l/300bar NANO, Type 4, NLL, AS</b>	The Dräger NANO, Type 4 full composite cylinder is specifically engineered to minimise the weight you carry during hazardous firefighting operations. Thus, it reduces fatigue and increases your agility. It is currently one of the lightest gas cylinders in the market with a shell weight of 2.8 kg (6.8 l of air/300 bar including impact-resistant caps). Designed with PET liner and carbon nanotube technology, it offers weight reduction by more than 47 % when compared to steel type 1 cylinders. Equipped with a lighter cylinder, you also benefit with a longer duration of air consumption and an increase of air supply if using a twinning option. The combination of light-weight sturdy cylinder material with impact-resistant caps ensures high durability and solid robustness.	2,8	579816206
	<b>Compressed-air cylinder 4 l/200 bar, Steel</b>	Valve G5/8" straight, Hand wheel of low flammability (FW), VS-G 5/8", Commissioning (TÜV).	11,8	579801563
	<b>Compressed-air cylinder 4 l/200 bar, Steel, AS</b>	Valve G5/8" straight, excess flow valve (EFV), Hand wheel of low flammability(FW), filled, VS-G 5/8", Commissioning (TÜV).	11,8	579801564
	<b>Compressed-air cylinder Dräger 6 l/300 bar, Steel</b>	Valve G5/8" straight, Handwheel of low flammability (FW), VS-5/8", Commissioning (TÜV).	9,7	579801565
	<b>Compressed-air cylinder Dräger 6 l/300 bar, Steel, AS</b>	Valve G5/8" straight, Excess flow valve (EFV), Hand wheel of low flammability (FW), VS-5/8", Commissioning (TÜV).	9,7	579801566
	<b>Compressed-air cylinder 6 l/300 bar, CFK, 30J, AS</b>	Design life: 30 years, Valve G5/8" straight, excess flow valve (EFV), Hand wheel of low flammability (FW), filled, VS 5/8"	6,3	579801567
	<b>Compressed-air cylinder Dräger 6,8l/300bar, CFK, 20J</b>	Design life: 20 years, Valve G5/8" straight, Hand wheel of low flammability (FW), filled, VS-5/8", Commissioning (TÜV).	6,96	579801569
	<b>Compressed-air cylinder 6,8 l/300 bar, CFK, AS, 20 J</b>	Design life: 20 years, excess flow valve (EFV), Valve G5/8" straight, Handwheel of low flammability (FW), filled, VS-5/8", Commissioning (TÜV).	6,96	579801570

## COMPRESSED-AIR CYLINDERS

Product	Name	Description	Weight (kg)	Part no.
	<b>Compressed-air cylinder 6,8 l/300 bar, CFK, 30 J</b>	Design life: 30 years, Valve G5/8" straight, Handwheel of low flammability(FW), filled, VS-5/8", Commissioning (TÜV).	7,19	579801571
	<b>Compressed-air cylinder 6,8 l/300 bar, CFK, short</b>	Design life: 15 years, short version, Valve G5/8" straight, Handwheel of low flammability(FW), filled, VS-5/8", Commissioning (TÜV).	6,86	579801572
	<b>Compressed-air cylinder 6,8 l/300 bar, CFK, AS, short</b>	Design life: 15 years, short version, Valve G5/8" straight, Excess flow valve (EFV), Handwheel of low flammability(FW), filled, VS-5/8", Commissioning (TÜV).	6,86	579801573
	<b>Compressed-air cylinder Dräger 6,8l/300bar, CFK,AS, 30J</b>	Design life: 30 years, Excess flow valve (EFV), Valve G5/8" straight, Handwheel of low flammability(FW), VS-5/8", Commissioning (TÜV).	5,4	579801574

### ACCESSORIES COMPRESSED-AIR CYLINDERS

 	<b>Cylinder protection cover Dräger Protex, M</b>	Size M, suitable for CFK cylinders 6,8 l and 6,0 l as well as steel cylinder 6 l.	2,42	579801575
	<b>Cylinder protection cover Dräger, Nomex, 6,8 l/300 bar CFK</b>	Cylinder protection cover (Nomex) for CFK-cylinder 6,8 l/300 bar	0,17	579804150

# Unstoppable

## DRÄGER PSS® AIRBOSS

With optimal ergonomics and future-proof connectivity our lightweight SCBA helps you to get any job done.

**Dräger**

Technology for Life











## RESPIRATORY MONITORING

Product	Name	Description	Weight (kg)	Part no.
	<b>Board for respiratory equipment monitoring Dräger REGIS 300</b>	The incident manager can monitor up to three teams simultaneously, with up to three wearers per team. Easy to read displays with countdown timers inform about the remaining deployment time according FwDV 7	1,72	579801502

### ACCESSORIES RESPIRATORY MONITORING BOARD DRÄGER

	<b>Name tags for REGIS 300/500 red</b>	With snap hook, quantity: 10 pieces	0,18	579801504
	<b>Name tags for REGIS 300/500 blue</b>	With snap hook, quantity: 10 pieces	0,18	579801505
	<b>Name tags for REGIS 300/500 yellow</b>	With snap hook, quantity: 10 pieces	0,18	579801506
	<b>Code plug for REGIS 500</b>	Coding plugs for standard and short time respiratory protective devices, 30 Min. Simply insert the coding plugs into the corresponding slots and the countdown starts automatically.	0,19	579801507
	<b>Code plug for REGIS 500</b>	Coding plugs for extended time respiratory protective device, or closed-cycle respiratory protective devices, 120 min. Simply insert the coding plugs into the corresponding slots and the countdown starts automatically.	0,19	579801508
	<b>External tracer for REGIS</b>	With built-in transmitter, flashing light connected to acoustic alarm, several REGIS can transfer alarms to one external tracer.	0,4	579804152
	<b>Transmitter for REGIS 500</b>	for REGIS 500, the transmitter reliably relays any alarm signals emitted by the monitoring board to the external tracer for up to 40 meters.	0,1	579804153
without image	<b>Expansion block</b>	Accessories for REGIS 300/500 monitoring board	0,1	579804151





## RESPIRATORY MONITORING

Product	Name	Description	Weight (kg)	Part no.
	<b>Checkbox 5+1 USB</b>	for five respiratory monitoring units and one reserve unit, electronic registration via transponder, four deployment scenarios (30; 60; 20; max. 240 min)	1,72	579805851
	<b>Transponder Chip for Checkbox 5+1</b>	Transponders uniquely identify the operative wearing a respiratory device	0,1	579805852
	<b>Zipper for Transponder</b>	To secure personal key on uniform, extendable	0,1	579805853
	<b>Suspension bracket Pölz</b>	for EUROBOX/Checkbox 5+1	0,1	579806984
	<b>Board for respiratory equipment monitoring Stuttgart</b>	Mechanic board for respiratory equipment monitoring to monitor up to three units of up to three operatives	1	579805389
	<b>Board for respiratory equipment monitoring atur-ME</b>	for 3 units, mechanic Board for respiratory equipment monitoring with e support, with acoustic and optical signals at expiry of the deployment time at 20,10,0 Min.	1,4	579806042
	<b>Board for respiratory equipment monitoring atur-X</b>	Electronic board for respiratory equipment monitoring according FwDV 7, deployment time adjustable (20,30,60 Min.), acoustic signal at expiry of deployment time.	1,2	579806727
	<b>Storage bag for Board for respiratory equipment monitoring</b>	Storage bag for Board for respiratory equipment monitoring Stuttgart and Gießen, as well as models of the atur series.	0,1	579805647
	<b>Mounting bracket for Board for respiratory equipment monitoring rescue-tec</b>	Bracket is suitable for all rescue-tec Board for respiratory equipment monitoring. Rung depth: 30 mm	0,1	579806658

## ESCAPE AND RESCUE DEVICES

Product	Name	Description	Weight (kg)	Part no.
	<b>Fire escape hood Dräger PARAT® 5510 Single Pack</b>	EN 403:2004. Combination filter CO P2, additional protection against H2S, (at 2.500 ppm) according DIN 58647-7	0,4	579801497
	<b>Fire escape hood Dräger PARAT® 5520 Soft Pack</b>	EN 403:2004. Combination filter CO P2, additional protection against H2S, (at 2.500 ppm) according DIN 58647-7. Robust fabric case (IP5). Viewing windows to check the filter expiration date and the condition of the device.	0,42	579801498
	<b>Fire escape hood Dräger PARAT® 5530 Hard Case</b>	EN 403:2004. Combination filter CO P2, additional protection against H2S, (at 2.500 ppm) according DIN 58647-7. Robust plastic case IP54. Protects against fire gases, vapours, and particles.	0,42	579801499
	<b>Fire escape hood Dräger PARAT® 5550</b>	EN 403:2004. Combination filter CO P2, additional protection against H2S, (at 2.500 ppm) according DIN 58647-7. Flame-retardant holster where the inner label can also be used for personalization, the holster can be attached to the breathing apparatus using the integrated belt loop with emergency release	0,706	579806008
	<b>Fire escape hood PARAT® 7520 Soft Pack</b>	EN 403:2004. Combination filter ABEK-CO-P3, additional protection against H2S, (at 2.500 ppm) according DIN 58647-7. Robust fabric case (IP5). Viewing windows to check the filter expiration date and the condition of the device.	1	579801500
	<b>Fire escape hood PARAT® 7530 Hard Case</b>	EN 403:2004. Combination filter ABEK-CO-P3, additional protection against H2S, (at 2.500 ppm) according DIN 58647-7. Robust plastic case IP54. Protects against fire gases, vapours, and particles.	1,06	579801501
	<b>Carrying bag Dräger for Fire escape hood PARAT® 5510</b>	For 2 x Parat 5510 Single Pack. With Velcro and adjustable shoulder strap.	0,22	579801496

## ESCAPE AND RESCUE DEVICES

Product	Name	Description	Weight (kg)	Part no.
	<b>Waist belt for Dräger PARAT® Fire escape hoods</b>		0,1	579809099
	<b>Shoulder belt for PARAT® Fire escape hoods</b>	Shoulder belt with integrated pins can be used in fixing point of Hard Case model or fixing loops of Soft Pack model.	0,1	579815777
	<b>Rescue Pack System Dräger RPS 3500, according FwDV 7</b>	Designed for use by rapid intervention teams according FwDV7. Content: PAS pneumatics, warning whistle and a precision pressure gauge, Y-piece, and middle pressure pipe with carabiner.	5,48	579801561
	<b>Rescue Pack System Dräger RPS 3500</b>	Designed for use by rapid intervention teams according FwDV7. Content: PPS rescue hood, PAS pneumatics, warning whistle and a precision pressure gauge, Y-piece, and middle pressure pipe with carabiner.	6,5	579804824
	<b>Rapid intervention team RIT-Bag</b>	for 6-9 Liter compressed-air cylinders, with directly connected pressure reduced, middle pressure pipe and Lung Demand Valve.	3	579805388
	<b>Rescue hood Dräger PSS, for emergency rescue</b>	Suitable for alle respiratory devices. Noise reduction for better communication. Simple and fast deployment.	0,746	579801562
	<b>Bag for rescue hood PSS</b>	Bag for rescue hood PSS	1,1	579804325
without image	<b>Middle pressure hose RPS 3500</b>	for rapid intervention team RIT-Bag RPS 3500	0,746	579805673
	<b>2D Wooden wedge made of hardwood</b>	Standard wooden wedge made of hardwood to secure escape route when firefighting.	0,2	579805424
	<b>3D Wooden wedge made of hardwood</b>		0,2	579805425

# HIGH-RESOLUTION & EFFICIENT THERMAL IMAGING CAMERA, PERFECT FOR INDOOR FIREFIGHTING

The thermal imaging camera offers an unbeatable price-performance ratio with superior and proven quality. The modular design allows for all firefighting-relevant functions and equipment options. This robust thermal imaging camera is ideal for all types of firefighting operations such as firefighting in buildings, search and rescue of people, hunting down remaining blazes, and many more. With the display modes FIRE & SEARCH, both the hottest spots (above 200°C) and the coldest spots are always in view.

## SCOPE OF DELIVERY

- 2 LiFePO4 batteries
- Charging accessories (230V / 12/24V) must be ordered separately
- 2 hand straps
- Extensive accessories available optionally

## WARRANTY

- 5 years for the camera
- 6 years for the batteries
- 10 years for the IR sensor
- 1 year for accessories (charging trays, cable chargers, etc.)

Part no. 579809307











#### CHARACTERISTICS

- 3.5" screen display
- 1-button operation
- Extensive warranty on camera, battery, and sensor
- Sensor resolution of 384x288 pixels
- Temperature range from -40°C to +1150°C
- Operating time of approximately 8 hours with 2 batteries (without video recording)
- Robust housing made of PUR/elastomer
- Protection class IP67
- Weight with battery & hand straps: 870 g
- Startup time < 5 seconds
- Compact dimensions (LxWxH) 165x140x85 mm
- 3.5" display with color scheme FIRE & SEARCH
- Heat resistance of housing up to 150°C for 15 min. / 260°C for 5 min

## THERMAL IMAGING CAMERAS MAGIRUS

Product	Name	Description	Weight (kg)	Part no.
	<b>Thermal imaging camera MAGIRUS TIC 3.1</b>	Display mode Fire and Search, Display size 90 mm (3,5"), 1-button-control, IP 67	0,8	579809297
	<b>Thermal imaging camera MAGIRUS TIC 3.1 Set</b>	incl. 2x Battery, 2x Hand strap, Zipper, vehicle charger 12/24V		579809307

### ACCESSORIES THERMAL IMAGING CAMERA MAGIRUS TIC 3.1

	<b>Replacement battery TIC</b>	LiFePo4-Battery, Life cycle > 5000 Charge cycles	0,2	579809302
	<b>Vehicle charger for TIC 3.1/3.3</b>	Adaptor required	0,2	579808553
	<b>Adaptor 12/24 V</b>	for Charging station	0,1	579807050
	<b>Carrying strap for TIC</b>	for Thermal imaging camera TIC 3.1, 3.3	0,1	579809298
	<b>Self-retracting Zipper</b>	for Thermal imaging camera TIC 3.1, 3.3	0,1	579809300
	<b>Protective hood for TIC</b>	for Thermal imaging camera TIC 3.1	0,1	579809299



## THERMAL IMAGING CAMERAS FLIR

Product	Name	Description	Weight (kg)	Part no.
	<b>Thermal imaging camera FLIR K1</b>	Thermal imaging camera FLIR K1 Description: IR resolution 160x120 Pixel, resolution 320x240 Pixel, Display size 2,4 Inch	0,41	579817156
	<b>Thermal imaging camera FLIR K2</b>	IR resolution: 160x120 pixels, Visual field 47x35°, temperature range: -20°C up to +500°C. Scope of delivery: 2x batteries, battery charger, carrying strap, adapter, user documentation in the form of manuals as well as on CD-ROM, USB cable.	0,7	579804672
	<b>Thermal imaging camera Flir K 33</b>	IR resolution: 240x180 Pixel, Visual field 51x38°, Temperature range: -20°C up to +650°C. Scope of delivery: Batteries (2x), Charger, Transportation case, extendable Carrying strap, Neck carrying strap, USB cable, manual	1,1	579805877
	<b>Thermal imaging camera Flir K 45</b>	IR resolution: 240 x 180 pixels, visual field 51x38°, temperature range: -20°C up to +650°C. Scope of delivery: hard shell case, tools software, charger, USB cable, pull-out strap, neck strap, retention strap, tripod adapter, 2x battery.	1,1	579800394
	<b>Thermal imaging camera Flir K 53</b>	IR resolution: 320x240 Pixel, Visual field 51x38°, Temperature range: -20°C up to +650°C, Scope of delivery: Hard shell case, Tools Software, Charger, 2 Batteries, USB cable, Pull-out strap, Neck strap, Retention strap, stand adapter.	1,1	579806285
	<b>Thermal imaging camera Flir K 55</b>	IR resolution: 320x240 Pixel, Visual field 51x38°, Temperature range: -20°C up to +650°C, Scope of delivery: Hard shell case, Tools Software, Charger, 2 Batteries, USB cable, Pull-out strap, Neck strap, Retention strap, stand adapter.	1,1	579800395



## ACCESSORIES THERMAL IMAGING CAMERAS FLIR

Product	Name	Description	Weight (kg)	Part no.
	<b>Thermal imaging camera Flir K 65</b>	IR resolution: 320x240 Pixel, Visual field 51x38°, Temperature range: -20°C up to +650°C, Scope of delivery: Hard shell case, Tools Software, Charger, 2 Batteries, USB cable, Pull-out strap, Neck strap, retention strap, stand adapter.	1,1	579805224
	<b>FLIR Vehicle set K1</b>	Consists of: Mounting bracket Thermal imaging camera, 12V/24V charging system, Assembly material, Manual	0,2	579817157
	<b>Replacement battery for Thermal imaging cameras K-Serie</b>	Lithium-Ion Battery with around 4 hours runtime.	0,15	579800397
	<b>Vehicle charger mount for Thermal imaging camera Flir K2</b>	To mount inside a firefighting vehicle.	0,175	579805270
	<b>Vehicle charger mount for Thermal imaging camera Flir K series</b>	To mount inside a firefighting vehicle. !!Not suitable for FLIR K2!!	2,2	579800396
	<b>Table charger for Thermal imaging camera K-Serie</b>	Table charger for Thermal imaging camera K series	0,165	579800398
	<b>USB cable for Thermal imaging camera K-Serie, Type Mini-B</b>	USB cable for Thermal imaging camera series, Type Mini-B	0,7	579800402
without image	<b>Adaptor for to mount inside a firefighting vehicle. K series incl. Code plug</b>	Use this adaptor when camera runs via network operation or to charge batteries.	0,25	579800404

## ACCESSORIES THERMAL IMAGING CAMERAS FLIR

Product	Name	Description	Weight (kg)	Part no.
	<b>Adapter 12 V DC Thermal imaging camera K series for cigarette lighter</b>	Adapter 12 V DC Thermal imaging camera K series for cigarette lighter, 1,2 m	0,06	579800405
	<b>Tool box for Thermal imaging camera K series</b>	Tool box for Thermal imaging camera K series	2,5	579800403
	<b>Carrying strap with self-closing Snap hook</b>	Carrying strap with self-closing snap hook.	0,125	579800399
	<b>Carrying strap for Thermal imaging camera K series</b>	Carrying strap for Thermal imaging camera K series	0,15	579800400
	<b>Shoulder belt for Thermal imaging camera K series</b>	Shoulder belt for Thermal imaging camera K series	0,55	579800401
without image	<b>Stand adapter K series</b>	Stand adapter FLIR K Serie	0,13	579800406

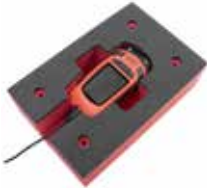
## THERMAL IMAGING CAMERA SEEK

Product	Name	Description	Weight (kg)	Part no.
	<b>Thermal imaging camera Seek Reveal FirePRO X</b>	<p>The Reveal FirePRO is one of the most advanced and compact thermal imaging cameras. Now, a new version of the rugged, durable, and easy-to-use Reveal FirePRO is available: the Reveal FirePRO X. The FirePRO X features a new magnetic charging plug that makes connecting the charging cable much easier. The other technical specifications remain unchanged.</p> <p>Features: Perfectly suited for all emergency forces as part of their Personal Protective Equipment (PPE), three selectable image modes (Color, Survey, Fire), 4 GB internal storage for up to 4,000 photos, integrated LED flashlight, high image resolution and frame rate for clear and meaningful images, robust two-component housing for a secure grip, innovative magnetic charging plug for easy charging.</p> <p>Scope of delivery: 1 Seek Reveal FirePRO-X unit, 1 USB charging and data cable, 1 USB adapter (220V), 1 hand strap, 1 stainless steel D-ring with mounting accessories.</p>	0,2	579816328
	<b>Vehicle charging mount for Reveal FirePRO</b>	<p>Hard foam holder for the Reveal FirePRO thermal imaging camera.</p>	0,3	579815548
	<b>GearKeeper equipment holder RT4 with Keyring</b>	<p>The GearKeeper is a practical equipment holder with a retractable mechanism.</p>	0,2	579815551
	<b>Dönges Holster for Seek Reveal Thermal imaging cameras</b>	<p>Practical nylon holster, suitable for cameras from the Seek Thermal Reveal series (PRO, FirePRO, ShieldPRO, XR).</p>	0,1	579816327

# ENVIRONMENTAL EQUIPMENT



## GAS DETECTION TECHNOLOGY

Product	Name	Description	Weight (kg)	Part no.
	<b>Gas detector Dräger X-am 2500</b>	Detects combustible gases and vapours: Ex.	0,8	579801594
		Detects combustible gases and vapours: Ex, O <sup>2</sup> (Oxygen).	0,8	579801595
		Detects combustible gases and vapours: Ex, O <sup>2</sup> (Oxygen), H <sup>2</sup> S-LC (Hydrogen sulphide).	0,8	579801596
		Detects combustible gases and vapours: Ex, O <sup>2</sup> (Oxygen), CO (Carbon monoxide). Without Power supply.	0,8	579801597
		Detects combustible gases and vapours: Ex, O <sup>2</sup> (Oxygen), CO (Carbon monoxide), H <sup>2</sup> S-LC (Hydrogen sulphide).	0,8	579801598
	<b>Gas detector Dräger X-am 2500 Flex</b>	Measures flammable gases and vapours depending on sensor selection, with special settings tailored to customer requirements.	0,8	579801618
	<b>Gas detector Dräger X-am® 3500 Basic</b>	Simultaneously measures up to 3 toxic and flammable gases/vapours and oxygen in pump or diffusion mode.	0,8	579816331
	<b>Gas detector X-am 5000</b>	Measures flammable gases and vapours depending on sensor selection, with special settings tailored to customer requirements.	1,418	579806399

Further sensors, configurations, and sensors upon request



## GAS DETECTION TECHNOLOGY

Product	Name	Description	Weight (kg)	Part no.
	<b>Battery Pack NiMH T4</b>	Nickel-Metal Hydride rechargeable battery	0,26	579801599
	<b>Battery Pack NiMH HC T4</b>	Nickel-metal hydride rechargeable battery, High-performance power pack for longer operating times	0,12	579801600
	<b>Lilon power pack for X-am® 3500</b>	Including back cover as replacement	0,12	579816333
	<b>Power pack and charging technology, Dräger, Set</b>	NiMH power supply unit T4, charging module, plug-in power supply (worldwide) for 1 charging module.	0,8	579801603
	<b>Charging module X-am</b>	For Gas detectors X-am 2500,5000, without Adapter.	0,304	579801605
	<b>Inductive back cover Dräger</b>	For Gas detectors X-am 3500 to charge device	0,4	579809376
	<b>Vehicle mount for Gas detector X-am 3500</b>		0,4	579809976
	<b>Vehicle adapter 12V/24V, Dräger</b>	Vehicle adapter for operating Pac III and X-am 2500, 5000.	0,084	579801606
	<b>Vehicle mount for 1 Charging module, Dräger</b>	Includes a holder and rubber strap for 1 charging module.	0,5	579801608
	<b>Strap for vehicle mount</b>	Additional holding strap for vehicle mount.	0,1	579801607

## GAS DETECTION TECHNOLOGY

ENVIRONMENTAL EQUIPMENT



Product	Name	Description	Weight (kg)	Part no.
	<b>External pump for X-am 2500,5000</b>	The device is inserted into the pump, which starts automatically. Hose length of 30 meters is allowed.	0,74	579801609
	<b>Hand pump adapter</b>	Adapter for Dräger X-am 2500, 5000 to operate device, for example, with a rubber bellows pump	0,27	579801610
	<b>CSE Case set for Dräger X-am 2500, 5000</b>	Scope of delivery: External pump including battery, carrying strap, Viton hose three meters.	1,68	579801611
	<b>Simultaneous Test Set I</b>	Measurement of acidic gases (hydrochloric acid), hydrogen cyanide, carbon monoxide, basic gases (ammonia), nitrogen oxide gases (nitrogen dioxide).	0,1	579801590
	<b>Simultaneous Test Set II</b>	Measurement of sulphur dioxide, chlorine, hydrogen sulphide, phosphine, phosgene.	0,1	579801591
	<b>Simultaneous Test Set III</b>	Measurement of ketones (acetone), alcohols (methanol), aromatics (toluene), aliphatic compounds (n-hexane), chlorinated compounds (perchloroethylene).	0,1	579801592

## GAS DETECTION TECHNOLOGY

Product	Name	Description	Weight (kg)	Part no.
	<b>Simultaneous Test Inorganic substances</b>	Measurement of carbon monoxide, hydrocyanic acid, hydrochloric acid, nitrous gas, formaldehyde.	0,1	579801593
	<b>Tube pump accuro</b>	Manual one-handed gas detector pump for short-term measurements.	0,44	579801588
	<b>Gas detector PAC 6000 CO</b>	ATEX approval, IECEx approval, measuring range 0-2000 ppm (CO), temperature range from -30 °C to +50 °C, IP68.	0,67	579808446
	<b>Gas detector PAC 6000 O<sup>2</sup></b>	ATEX approval, IECEx approval, measuring range 0-25 vol.-% (O <sup>2</sup> ), temperature range from -30 °C to +50 °C, IP68.	0,67	579808447
	<b>Gas detector PAC 6500 CO</b>	ATEX and IECEx approval, measuring range 0-2000 ppm (CO), alarm threshold 30/60 ppm, temperature range from -30 °C to +55 °C, IP68.	0,67	579808448
	<b>Gas detector PAC 6500 O<sup>2</sup></b>	ATEX and IECEx approval, measuring range 0-25 vol.-% (O <sup>2</sup> ), temperature range from -30 °C to +55 °C, IP68.	0,67	579808449
	<b>Gas detector PAC 8500 H<sup>2</sup>S/CO</b>	ATEX and IECEx approval, measuring range 0-100ppm (H <sup>2</sup> S) 0-2000ppm (CO), alarm threshold H <sup>2</sup> S 5/10ppm, CO 30/60 ppm, IP68.	0,67	579808450
	<b>Gas detector PAC 8500 O<sup>2</sup>/CO</b>	ATEX and IECEx approval, measuring range 0-100ppm (H <sup>2</sup> S) 0-2000ppm (CO), alarm threshold H <sup>2</sup> S 5/10ppm, CO 30/60 ppm, IP68.	0,67	579808451

## DOSE RATE METER

ENVIRONMENTAL EQUIPMENT

Product	Name	Description	Weight (kg)	Part no.
	<b>Dose Rate Meter 6150AD1/E</b>	For dose rates below 10 mSv/h. Areas for dose rate (DL) and photon energy: DL analogue: 1 $\mu$ Sv/h - 1000 mSv/h, DL digital: 0,1 $\mu$ Sv/h - 999 mSv/h, DL calibratable: 0,2 mSv/h - 999 mSv/h, Energy range: 45 keV - 2,6 MeV Additional features: no	0,4	579800479
	<b>Dose Rate Meter 6150AD5/E</b>	For dose rates below 10 mSv/h. Areas for dose rate (DL) and photon energy: DL analogue: 1 $\mu$ Sv/h - 1000 mSv/h, DL digital: 0,1 $\mu$ Sv/h - 999 mSv/h, DL calibratable: 0,2 mSv/h - 999 mSv/h, Energy range: 45 keV - 2,6 MeV Additional features: yes	0,4	579800481
	<b>Dose Rate Meter 6150AD2/E</b>	If dose rates above 10 mSv/h are not expected, the 6150AD2/E or AD6/E is preferable because the more sensitive detector is better suited for low levels. Areas for dose rate (DL) and photon energy: DL analogue: 1 $\mu$ Sv/h - 1000 mSv/h, DL digital: 0,1 $\mu$ Sv/h - 999 mSv/h, DL calibratable: 0,2 mSv/h - 999 mSv/h, Energy range: 45 keV - 2,6 MeV Additional features: no	0,4	579800478
	<b>Dose Rate Meter 6150AD6/E</b>	If dose rates above 10 mSv/h are not expected, the 6150AD2/E or AD6/E is preferable because the more sensitive detector is better suited for low levels. Areas for dose rate (DL) and photon energy: DL analogue: 1 $\mu$ Sv/h - 1000 mSv/h, DL digital: 0,1 $\mu$ Sv/h - 999 mSv/h, DL calibratable: 0,2 mSv/h - 999 mSv/h, Energy range: 45 keV - 2,6 MeV Additional features: yes	0,4	579800480
without image	<b>Gamma probe 6150AD-15/E</b>	Calibratable, high dose power probe, power supply from 6150AD.		579800498
without image	<b>Gamma probe 6150AD-18/E</b>	Calibratable, low dose power probe, power supply from 6150AD.		579800497
	<b>Teletector Probe 6150AD-t/E</b>	The calibratable Teletector Probe 6150AD-t/E is a portable probe which, in conjunction with a dose rate meter 6150AD, is used to measure photon radiation (gamma and X-rays) in the quantity of H*(10).		579800491
	<b>Scintillator Probe 6150AD-b/E</b>	The 6150AD-b/E scintillator probe only works with the 6150AD5/E and 6150AD6/E versions of the dose rate meter. The power supply comes from the 6150AD.		579800496

## HAZARDOUS MATERIALS FITTINGS

Product	Name	Description	Weight (kg)	Material	Part no.
	<b>Adapter Storz C 52 to Thread DN50</b>	Threaded coupling, Adapter with Seal	1,35	Stainless steel	579802548
	<b>Adapter TW-MK 50 to Storz C 52</b>	Adapter with Seal	1,35		579802569
	<b>Adapter Storz, C 52 to TW-VK 50</b>	Adapter with Seal	1,35		579802571
	<b>Adapter TW VK80 to DN50</b>	Connection piece with Seal	1,5		579802581
	<b>Adapter TW VK80 to VK50</b>	Connection piece with Seal	2		579802583
	<b>Adapter TW MK80 to DN50</b>	Connection piece with Seal	2		579802584
	<b>Adapter TW MK80 to VK50</b>	Connection piece with Seal	1		579802585
 image might vary	<b>Suction pipe for acid DN50/Storz C 52</b>	Pipe approximately 1000 mm long, with foot valve, protective cage, and pipe elbow, with cold protection cover (45°).	1,3	Stainless steel	579802556
	<b>Suction pipe for acid DN32/Thread DN50</b>	Pipe approximately 1000 mm long, with foot valve, protective cage, and pipe elbow, with cold protection cover (45°).			579802600
	<b>Suction pipe for acid DN32/TW-VK50</b>	Pipe approximately 1000 mm long, with foot valve, protective cage, and pipe elbow, with cold protection cover (45°).			579802601
without image	<b>Spout DN50/ Storz C 52</b>	Safety spout with a 90° pipe bend, sieve cylinder, and footplate, cold protection, and seal. 1000 mm long.	5	Stainless steel	579802557
	<b>Spout DN50/ Thread DN50</b>	Safety spout with a 90° pipe bend, sieve cylinder, and footplate, cold protection, and seal. 1000 mm long.	5		579802602
	<b>Spout DN50 TW-MK50</b>	Safety spout with a 90° pipe bend, sieve cylinder, and footplate, cold protection, and seal. 1000 mm long.	5		579802603
	<b>Quick-connect faucet Storz C 52</b>	With Seals, DN 50, 2x Storz C	0,6		579802558

## HAZARDOUS MATERIALS FITTINGS

ENVIRONMENTAL EQUIPMENT



Product	Name	Description	Weight (kg)	Material	Part no.
 without image  without image	<b>Suction basket DN50</b>	With Perbunan valve ball, foot plate with suction strainer and seals.	1,6	Stainless steel	579802560
	<b>Suction basket DN50 TW- MK50</b>	With Perbunan valve ball, foot plate with suction strainer and seals.			579802561
	<b>Suction basket DN50 TW- VK50</b>	With Perbunan valve ball, foot plate with suction strainer and seals.			579802562
	<b>Suction basket DN50, Storz C</b>	With Perbunan valve ball, foot plate with suction strainer and seals.			579806441
 image might vary	<b>Measuring pipe DN50 K/M DN50</b>	Pipe 45° elbow, 300mm long with seal, tapered connection/nut	0,4	Stainless steel	579802565
	<b>Measuring pipe DN50 TW-MK 50</b>	Pipe 45° elbow, 300mm long with seal			579802566
	<b>Measuring pipe DN50 TW-VK 50</b>	Pipe 45° elbow, 300mm long with seal			579802567
 image might vary	<b>Pipe elbow 90° DN50 G-K/M DN50</b>	Pipe elbow with Seal side length ca. 350mm	1,5	Stainless steel	579802572
	<b>Pipe elbow 90° DN50 TW-MK/VK 50</b>	Pipe elbow with Seal, side length ca. 350mm			579802573
without image	<b>Pipe elbow 45° DN50 G-K/M DN50</b>	Pipe elbow with Seal side length ca. 350mm	1,5	Stainless steel	579802574
	<b>Pipe elbow 45° DN50 TW-MK/VK 50</b>	Pipe elbow with Seal, side length ca. 350mm	1,5	Stainless steel	579802575
	<b>Connection piece DN50</b>	Connection piece with Seal Tapered connection/nut x tapered connection/nut	1	Stainless steel	579802576
	<b>Connection piece Thread both ways DN50</b>	Connection piece with Seal, Thread x Thread	0,9	Stainless steel	579802578
without image	<b>Spacer for Tank wagon KWZ 5½ to DN50</b>	Tank wagon spacer KWZ 5½ with Seal	3	Stainless steel	579802591
	<b>Spacer for Tank wagon KWZ 5½ to TW- VK50</b>	With VK 50 Tank wagon coupling Tank wagon spacer KWZ 5½ with Viton Seal	3	Stainless steel	579802592

## HAZARDOUS MATERIALS FITTINGS

Product	Name	Description	Weight (kg)	Material	Part no.
without image	<b>Flange with counter flange G DN50</b>	Threaded fitting for integration into collapsible tanks, seal, chain, cap & screw, self-locking nuts.	0,5	Stainless steel	579802598
	<b>Flange with counter flange TW/VK50</b>	Threaded fitting for integration into collapsible tanks, seal, chain, cap & screw, self-locking nuts.			579802599
	<b>C-wrench DN25-65</b>	DIN 1810	0,2	Stainless steel	579802604
	<b>C-wrench DN65-100</b>	DIN 1810			579802605







## HAZARDOUS MATERIAL PUMPS/DIAPHRAGM PUMP

ENVIRONMENTAL EQUIPMENT

Product	Name	Description	Weight (kg)	Part no.
	<b>Hazardous material transfer pump MAST GUP 3-1,5</b>	DIN 14427:2013-12, explosion-proof, acid couplings DN 50, self-priming up to 8.4 m, 400V, 1.5 m connecting cable CEE.	81	579800265
	<b>Hazardous material transfer pump MAST GUP 3-1,5 TW</b>	DIN 14427:2013-12, explosion-proof, tank truck couplings TW 50, suction side VK 50, pressure side MK 50, self-priming up to 8.4 m, 400V, 1.5 m connecting cable CEE.	81	579800266
	<b>Hazardous material pump ELRO GUP 3 - 1,5-RV</b>	DIN 14427:2013-12, explosion-proof, acid couplings DN 50, self-priming up to 9 m, 400V, 1.5 m connecting cable with explosion-protected plug CEAG	110	579800357
	<b>Hazardous material pump ELRO GUP 3 - 1,5-TW</b>	DIN 14427:2013-12, explosion-proof, tank wagon couplings DN 50, self-priming up to 9 m, 400V, 1.5 m connecting cable with explosion-protected plug CEAG, connection coupling TW MK 50	110	579800358
	<b>Hazardous material transfer pump ELRO GP 20/10 EX</b>	Explosion-protected, connection nozzle KL manifold (stainless steel), self-priming up to 9 m, 400V, 1.5 m connection cable with CEAG Ex-plug	100	579800359
	<b>Connection kit for GP 20/10 EX with C coupling</b>		10	579800360
	<b>Diaphragm pump Storz C 52</b>	Pump for transferring heavily contaminated media, maximum delivery head appr. 6m, maximum suction lift appr. 5m, highly resistant to acids and alkalis, made of stainless steel	11,6	579802549
	<b>Diaphragm pump K/M-G DN50</b>	as part no. 579802549	11,6	579802550
	<b>Diaphragm pump TW-MK50/ VK50</b>	as part no. 579802549	11,6	579802551







## ADDITIONAL HAZARDOUS MATERIAL PUMPS

Product	Name	Description	Weight (kg)	Part no.
	<b>Barrel pump set JESS-BERGER JP-280 ALU 230 V</b>	Complete pump set for petroleum products. Incl.: 2 m mineral oil hose 1" (NW 25), 2 pcs. hose clamps stainless steel, 1 pc. Dispensing gun aluminum 1". Immersion depth: 1000 mm, Flow rate: 112 l/min, Head: 16 m, Medium temperature: max.50 °C, Viscosity: 1000 mPas, Density: 1.9	8	579819712
	<b>Barrel pump set JESS-BERGER JP-164 24 V, 400 W</b>	Complete pump set for mineral oil products. Incl.:2 m mineral oil hose 1" (NW 25)2 pcs. hose clamps stainless steel1 pc. Dispensing nozzle aluminum 1". Immersion depth: 1000 mm, Flow rate: 66 l/min, Head: 7,5 m, Medium temperature: max.80 °C, Viscosity: 300 mPas, Density: 1.3	8	579819714
	<b>Barrel pump set JESS-BERGER EX-JP-440</b>	Complete pump set for flammable media. Incl: 2 m multi-purpose hose, conductive 1" (NW 25) 2 hose connections made of stainless steel 1.4571, internal thread 1 1/4" or internal thread 1" respectively1 tap gun made of nickel-plated brass, 1" (DN 25)1 potential equalization cable set (anti-static set). Immersion depth: 1000 mm, Flow rate: 82 l/min, Head: 9 m, Viscosity: 400 mPas, Density: 1.3	10	579819713
	<b>Extraction device, emergency suitcase pump</b>	Air-operated double diaphragm pump, robust and lightweight, resistant to acids and bases, 200-300 l pumping capacity with a compressed air cylinder	12,88	579804667
	<b>Hand pump K 10 C</b>	Hose set, hand-operated piston pump for pumping from barrels and small containers.	2,4	579816273
	<b>Telescopic tube</b>	extendable length 490 - 925 mm		579816274
	<b>Emergency suitcase pump Albert Kuhn</b>	consisting of: double diaphragm pump, 2m pressure hose, 1.5m suction hose, 2m suction hose with strainer, 7m air hose, pressure regulator 300bar, earthing cable, case.	9,1	579806457
	<b>Hand pump UV Alu with hose kit</b>	Volume 720ml, with Hose 1500mm	2,4	579807167

## CONTAINMENT TANKS

Product	Name	Description	Weight (kg)	Part no.
	<b>Containment tank for Extinguishing water, Protect</b>	Space-saving liquid storage tank for firefighting operations, emergencies, and environmental protection. It automatically erects itself when filled, no support frame required. Easily transportable thanks to small packing size. Suitable for storing extinguishing water and process water. Overall diameter: 225 cm.  Round, open at the top, self-erecting with a floating collar.	16	579802627 3000 l
			22	579802625 5000 l
	<b>Containment tank for Oil, Protect</b>	Space-saving liquid storage tank for firefighting operations, emergencies, and environmental protection. It automatically erects itself when filled, no support frame required. Easily transportable thanks to small packing size. Suitable for storing extinguishing water and process water. Overall diameter: 225 cm.  Round, open at the top, self-erecting with a floating collar.	18	579802628 3000 l
			27	579802629 5000 l
	<b>Containment tank closed 3000 l for Oil, Protect</b>  <b>Containment tank closed 5000 l for Oil, Protect</b>	Closed and cushion-shaped, material weight 1100 g/m <sup>2</sup> , tear strength 2500 N/50 mm, resistant to mineral oil.	23	579802630
			38	579802631
	<b>Containment tank PVC 3.000 l, open, with Support frame, Folding silo</b>	Incl. Packing bag and repair kit.	44	579800000
	<b>Containment tank open PVC 5.000 l, Folding silo</b>	Open Containment tank self-erecting from PES/PVC. Volume 5000 l.	23	579800003

## CONTAINMENT TANKS

Product	Name	Description	Weight (kg)	Part no.
<b>ACCESSORIES CONTAINMENT TANK</b>				
without image	<b>Packing bag for Capacity 1000 l - 3000 l</b>	PVC coated, for Extinguishing water & Mineral oil Containment tank, Capacity 1000 l - 3000 l.	1,5	579802632
	<b>Packing bag for Capacity 5000 l - 10000 l</b>	PVC coated, for Extinguishing water & Mineral oil Containment tank, Capacity 5000 l - 10000 l.	1,7	579802633
	<b>Filling/drainage fittings Alu DN 110</b>	Filling/drainage fittings made of Aluminium DN 110	9	579815481
	<b>Filling/drainage fittings VA DN 52</b>	Filling/drainage fittings made of Stainless steel DN 50 Tank wagon / acid coupling	4	579800007
	<b>Filling/drainage fittings Messing DN 52</b>	Filling/drainage fittings made of brass DN 52	3,5	579800002
	<b>Double-acting piston pump</b>	Double-acting piston pump for filling the float collar of containment tanks	0,9	579800008
	<b>Ground sheet 4 x 4 m</b>	Ground sheet 4 x 4 m PES/PVC for open containment tank 5000 l.	15	579800009
	<b>Ground sheet 2 x 2,5 m</b>	Ground sheet 2 x 2,5 m Alcryn for open containment tank 5000 l.	7	579800010
	<b>Containment tarpaulin for Oil 4 x 4 m with hand straps</b>	PVC coated	21	579802634

## CONTAINMENT BASIN

ENVIRONMENTAL EQUIPMENT





Product	Name	Description	Weight (kg)	Part no.
	<b>Emergency basin Otter Type 60</b>	45 l, space-saving, large capacity, flexible basin shape. Quickly deployable, easy to clean, quick to stow.	1,7	579800505
	<b>Emergency basin Otter Type 80</b>	102 l, space-saving, large capacity, flexible basin shape. Quickly deployable, easy to clean, quick to stow.	3	579800507
	<b>Emergency basin Otter Type 100</b>	160 l, space-saving, large capacity, flexible basin shape. Quickly deployable, easy to clean, quick to stow.	3,7	579800509
	<b>Packing bag for Emergency basin Otter Type 60</b>	Suitable for containment basin, 45 l, 60 x 60 cm.	0,2	579800506
	<b>Packing bag for Emergency basin Otter Type 80</b>	Packing bag for containment basin, 102 l, 80 x 80 cm.	0,35	579800508
	<b>Packing bag for Emergency basin Otter Type 100</b>	Packing bag for containment basin, 160 l, 100 x 100 cm.	0,4	579800510
	<b>Containment basin Ecco- tarp ET 01 S Set</b>	For short-term storage of industrial liquids, oil products, and chemicals, set consists of a 25 l containment basin, bag, protective liner, and ground sheet.	2,9	579808281
	<b>Containment basin Ecco- tarp, ET 02 M</b>	Volume 75 l, for short-term storage of industrial liquids, oil products, and chemicals, with bag.	4	579809009
	<b>Multi-purpose containment basin ECCOTARP ET 03 L</b>	Volume 175 l, for short-term storage of industrial liquids, oil products, and chemicals.	4	579809010
	<b>Containment basin, Ecco- tarp ET 03 L Set, 175 l</b>	For short-term storage of industrial liquids, oil products, and chemicals, set consists of a 175 l containment basin, bag, protective liner, and ground sheet.	5,6	579807476
	<b>Multi-purpose containment basin ECCOTARP ET 04 XL DECON</b>	Volume 450 l, For short-term storage of industrial liquids, oil products, and chemicals.	9,8	579805714
	<b>Multi-purpose containment basin ECCOTARP ET 051 XXL EASYPACK</b>	Volume 1600 l, For short-term storage of industrial liquids, oil products, and chemicals.	9,8	579808397

## CONTAINMENT DEVICES AND CONTAINERS

Product	Name	Description	Weight (kg)	Part no.
	<b>Foldable containment funnel ECCOTARP</b>	Comes standard with aluminium fire department coupling C52.	3	579805783
	<b>Drip mat Ecco tarp Type 1000 P</b>	Equipped with a replaceable absorbent insert, can be hung, or anchored in windy weather.	1,5	579807586
without image	<b>Absorbent lining Ecco tarp for Drip mat 1000P Universal</b>	The absorbent lining should be chosen according to the type of liquid to be collected: universal, water-repellent, chemical-resistant.	0,5	579807587
	<b>Run-off containment</b>	4 pieces, made of stainless steel, stackable.	14,5	579803381
	<b>Run-off containment</b>	4 pieces, made of stainless steel, stackable.	0,6	579802613
	<b>Wide-neck canister 6 l, HD-PE</b>	Opening Ø 88 mm, Professional version for versatile applications, undetachable, wide-neck screw cap with retention strap.	1,39	579816111
	<b>Wide-neck canister 22 l, HD-PE</b>	Opening Ø 88 mm, ideal for storing drinking water and food, and has good chemical resistance against fats, resins, alkalis, oils, and acids.	1,39	579804403
	<b>Wide-neck canister 20l, square, screw cap and 2 handles</b>	For the storage of oil-binding agents, screw cap D-150/140. White with red lid.	1	579804923
	<b>Foaming agent canister - Plastic, 20 l, empty, yellow</b>	DIN 14452. Empty. Specifically for vehicle loading according to DIN and wall hydrant cabinets.	1,4	579804404
	<b>Hand ladle with handle 1 l</b>	1 l With Stainless steel handle and cold protection.	0,3	579802611
	<b>Hand ladle with handle</b>	5 l With Stainless steel handle and cold protection.	0,5	579802612

## CONTAINMENT DEVICES AND CONTAINERS

ENVIRONMENTAL EQUIPMENT







Product	Name	Description	Weight (kg)	Part no.
	<b>Funnel for transferring liquids</b>	Diameter 250 mm	0,5	579802614
without image	<b>Funnel 250 mm</b>	Diameter 250 mm.	0,5	579803304
	<b>Bucket 10 l, stainless steel</b>	Without base ring, 10 l.	2	579802615
	<b>Bucket 15 l</b>	With base ring, 15 l.	2	579802616
without image	<b>Lid for 15 l Bucket</b>	For 15 l Bucket.	0,1	579802617
	<b>Mortar bucket / construction bucket 12 l</b>	Without base ring, 10 l.	0,4	579804616

## DECONTAMINATION EQUIPMENT

Product	Name	Description	Weight (kg)	Part no.
	<b>Wedges for sealing, set, Wood, 20 pieces.</b>	DIN 14555-T3. Packed in synthetic fibre bag.	20	579803294
	<b>Plugs for sealing, set 20 pieces.</b>	DIN 14555-T3. Packed in synthetic fibre bag.	30	579803295
	<b>Plugs for sealing, Wood, 12 pieces</b>	DIN 14555-T3. Packed in synthetic fibre bag.	2,1	579805394
	<b>Plugs for sealing, 20 pieces.</b>	Made of Soft wood, 5 x 90/25 mm Ø, 5 x 60/10 mm Ø, 10 x 30/10 mm Ø, packaged approx. 3 kg.	20	579804680
	<b>Rubber sealing collar DEN- SO®-Tec</b>	The collar is impermeable to moisture and stable against aqueous electrolyte solutions.	1,2	579803296
	<b>Hemp for sealing</b>	Set with 5 pieces in polybag.	1	579803297
	<b>Sealant - Plastic-Fermit</b>	Temperature resistant from -20° C to +100° C.	0,3	579803298
	<b>Mouldable sealant</b>	Paste-like, shapeless, plastic.	0,5	579803299
	<b>Sealing paste - Leck-Stop</b>	Applicable in case of accidents involving liquid chemicals, such as alkaline, acidic, cleaning agents, etc. In case of particularly aggressive or strongly separating chemicals, the sealing may need to be repeated.	0,7	579803301
	<b>Sealing tape - PTFE</b>	Pure sintered PTFE tape, chemically resistant to aggressive media, length 12m, width 12mm.	0,1	579803356
	<b>ChemTape® 55 m- Role, 50 mm wide</b>	Special adhesive tape for sealing seams and taping gloves, boots, and chemical protective suits.	0,5	579804661
	<b>Lead wool</b>	Versatile. Capacity: 2 kg, packaged in Polybag.	2	579803357
without image	<b>Cleaning wool</b>	Cleaning wool in bag	2	579804691



## DECONTAMINATION EQUIPMENT

ENVIRONMENTAL EQUIPMENT

Product	Name	Description	Weight (kg)	Part no.
	<b>Canal quick-sealant Drain stop, complete set</b>	Complete set 70 x 70. Drain stop individual 70 x 70. Antifreeze concentrate 10 l canister. Wall mount.	15	579803302
	<b>Canal quick-sealant Drain stop</b>	Drain stop individual 70 x 70	0,9	579803303
	<b>Magnetic drain cover Magni-Seal 60x60 cm</b>  <b>Magnetic drain cover Magni-Seal 100x100 cm</b>	adheres to magnetic surfaces; can be stored rolled up; easy to handle, ideal for emergency measures	0,5	579804655  579806442
	<b>Drain cover 750 x 750 mm</b>	Resistant to mineral oil and liquid-tight. Tear-resistant.	1,9	579803335
	<b>Foam seal plate</b>		1,7	579803336
	<b>Spill bag 15</b>	Oil- and chemical-resistant. Self-sealing for safe transport of captured liquids. Volume 15 l.	5	579803337
	<b>Spill bag 100</b>	Oil- and chemical-resistant. Self-sealing for safe transport of captured liquids. Volume 100 l.	0,8	579803339









## DECONTAMINATION EQUIPMENT

Product	Name	Description	Weight (kg)	Part no.
	<b>Tarpaulin 4 x 6 m</b>	Heavy, multi-layered tarpaulin. Resistant to mineral oil, with mesh fabric and eyelets on the edges. Double, tape-reinforced edge.	2	579803360
	<b>Woven tarpaulin 4 x 5 m</b>	Heavy, multi-layered tarpaulin. Resistant to mineral oil, with mesh fabric and eyelets on the edges. Double, tape-reinforced edge.	1,6	579806065
without image	<b>Sand bag made of jute</b>	With fastener	0,1	579803313
	<b>Flat bag made of polyethylene</b>	Made of transparent polyethylene.	0,4	579803314

## BINDING AGENTS

ENVIRONMENTAL EQUIPMENT

Product	Name	Description	Weight (kg)	Part no.
	<b>Oil binding agents Oil-Ex 82</b> Type I+II+III/RSF	Oil and chemical absorbent, universal, medium weight granules, for floors and bodies of water, packaging of 40 l per bag	10	579800500
	<b>Oil binding agents Puren Oil-Ex Allwetter</b> Type III/R	Oil and chemical absorbent, lightweight, for floors and roads. Packaging: 40 l per bag	15	579800502
	<b>Oil binding agents Oil-Ex hart</b> Type III/R	Oil and chemical absorbent, for large bodies of water, harbour basins, and wastewater treatment plants, for long-term use. Packaging: 45 l per bag.	23	579800503
	<b>Oil binding agents Oil-Ex Würfel</b> Type I+II/SF	Oil and chemical absorbent, for large bodies of water, harbour basins, and wastewater treatment plants, for long-term use. Packaging: 45 l per bag.	10	579800504
	<b>BioVersal BSG 8 PE Continuous pressure spray device</b>	With hand pump unit, operating pressure of 3 bar. For 8 l of BioVersal-water mixture (1:25). Coverage of up to 18 square meters or 90 meters of oil spill.	10,4	579806565
	<b>BioVersal Concentrate Canister 10 kg</b>	Liquid oil remover, pH-neutral, easily biodegradable, dermatologically tested, approved as oil spill clean-up agent: MPA NRW - Approval no. 22 000 2061 03.	10	579805613

## BINDING AGENTS

Product	Name	Description	Weight (kg)	Part no.
	<b>BioVersal Concentrate Canister 25 kg</b>	Liquid oil remover, pH-neutral, easily biodegradable, dermatologically tested, approved as oil spill clean-up agent: MPA NRW - Approval no. 22 000 2061 03.	25	579809180
	<b>Oil barrier HexaDyn 0,13mx3m</b>	Oil absorbent barrier with connecting hooks, holding capacity of 222 L. Sales unit = 4 barriers	10	579802488
	<b>Oil barrier HexaDyn 0,13x5m</b>	Oil absorbent barrier with connecting hooks, holding capacity of 169 L. Sales unit = 4 barriers	8,3	579802489
	<b>Oil barrier HexaDyn 0,20x3m</b>	Oil absorbent barrier with connecting hooks, holding capacity of 350 L. Sales unit = 4 barriers	15,2	579802490
	<b>Oil barrier HexaDyn 0,20x5m</b>	Oil absorbent barrier with connecting hooks, holding capacity of 297 L. Sales unit = 4 barriers	12,5	579802491
	<b>Oil-absorbent cloth HexaDyn 0,5x0,4m Type WDP 101</b>	Cloth to absorb oil, absorption capacity 144 l.	7,2	579802492
	<b>Oil-absorbent cloth HexaDyn 0,40x0,5m</b>	Cloth to absorb oil, absorption capacity 113l	6	579802493
	<b>Oil-absorbent role HexaDyn 0,40x40m</b>	Role to absorb oil, absorption capacity 180 l	8,6	579802494
	<b>Oil-absorbent role HexaDyn 0,80x40m</b>	Role to absorb oil, absorption capacity 180 l	8,6	579802495
	<b>Oil-absorbent curtain HexaDyn 0,48x30m</b>	Oil absorbent curtain with longitudinal rope to connect, absorption capacity 160l	12	579802496
	<b>Oil-absorbent emergency set B HexaDyn</b>	Emergency set with various oil-absorbent products, absorption capacity 50l	3,5	579802497
	<b>Chemical-absorbent emergency set B HexaDyn</b>	Emergency set with various chemical-absorbent products, absorption capacity 50l	3,5	579802498

## BINDING AGENTS

ENVIRONMENTAL EQUIPMENT

Product	Name	Description	Weight (kg)	Part no.
 	<b>Oil-absorbent role HexaDyn 0,40x15 m</b>	Role to absorb oil, absorption capacity 24l	2,1	579802499
	<b>Chemical-absorbent role HexaDyn 0,40x15 m</b>	Role to absorb chemicals, absorption capacity 24l		579802500
   	<b>Universal Binding cord HexaDyn 7,5 cm x 1,20 m</b>	Suction hose to absorb oil, absorption capacity 80l	8	579802501
	<b>Binding cord for chemicals HexaDyn 7,5 cm x 1,20 m</b>	Suction hose to absorb chemicals, absorption capacity 80l		579802502
	<b>Universal Binding cord HexaDyn 7,5 cm x 3 m</b>	Suction hose to absorb oil, absorption capacity 80l		579802503
	<b>Binding cord for chemicals HexaDyn 7,5 cm x 3 m</b>	Suction hose to absorb chemicals, absorption capacity 80l		579802504
 	<b>Universal absorption cloth „First“ Light weight, 0,40 x 0,50 m</b>	Cloth to absorb all types of liquids, absorption capacity 144l	7,2	579802505
	<b>Absorption cloth for chemicals „First“ Light weight, 0,40 x 0,50 m</b>	Cloth to absorb chemicals, absorption capacity 144l		579802511
 	<b>Universal absorption cloth „First“ Heavy weight, 0,40 x 0,50 m</b>	Cloth to absorb all types of liquids, absorption capacity 113l	6	579802506
	<b>Absorption cloth for chemicals „First“ Heavy weight, 0,40 x 0,50 m</b>	Cloth to absorb chemicals, absorption capacity 113l		579802512

## BINDING AGENTS

Product	Name	Description	Weight (kg)	Part no.
	<b>Chemical-absorbent role „First“ Light weight, 0,40 x 60 m</b>	Role to absorb chemicals, absorption capacity 173l	8,6	579802513
	<b>Universal absorption role „First“ Light weight, 0,40 x 60 m</b>	Role to absorb all types of liquids absorption capacity 173 l		579802507
	<b>Universal absorption role „First“ Light weight, 0,80 x 60 m</b>	Role to absorb all types of liquids absorption capacity 173 l		579802508
	<b>Chemical-absorbent role „First“ Light weight, 0,80 x 60 m</b>	Role to absorb chemicals, absorption capacity 173 l		579802514
	<b>Universal absorption role „First“ Heavy weight, 0,40 x 60 m</b>	Role to absorb all types of liquids, absorption capacity 180 l	7,2	579802509
	<b>Universal absorption role „First“ Heavy weight, 0,80 x 60 m</b>	Role to absorb all types of liquids, absorption capacity 180 l		579802510
	<b>Chemical-absorbent role „First“ Heavy weight, 0,40 x 60 m</b>	Role to absorb chemicals, absorption capacity 180 l		579802515
	<b>Chemical-absorbent role „First“ Heavy weight, 0,80 x 60 m</b>	Role to absorb chemicals, absorption capacity 180 l		579802516



# PERSONAL PROTECTIVE EQUIPMENT (PPE)





## FIREFIGHTER CLOTHING

Product	Name	Description	Size	Part no.
	<p><b>Combat jacket WATEX Fire-Brake</b></p>	<p>EN 469:2005, Xf2/Xr2/Y2/Z2, reflective stripes analogous HuPF Part 1 07/20, PSA Cat. III</p> <p>Large turn-down collar with wide collar flap to completely cover the collar opening, flap with Velcro closure, front with quick-release zipper, two inserted side pockets with flaps and Velcro closure, under the left flap a loop with carabiner hook.</p> <p>Mounted FUG pockets with flaps and Velcro closure on the left and right side of the chest. Under the flap, a Velcro strip is attached to secure the radio device. Microphone holders are located on the left and right shoulder area.</p> <p>Above the chest pockets, there is a loop tape for name patches or to attach a shoulder pad. Holder for a bendable headlamp on the front cover strip. The sleeves have tabs and Velcro closure for width adjustment, plus movement gusset in the armpit area. Wind protection with knitted cuffs in the sleeves.</p> <p>Attached interior pocket on the right with Velcro closure and a detachable back patch in fluorescent yellow with the inscription FIRE DEPARTMENT.</p> <p>Features:</p> <ul style="list-style-type: none"> <li>- Base color dark blue with yellow contrasting threads</li> <li>- Shoulder pads firmly sewn into outer fabric</li> <li>- Elbow reinforcement made of silicone-coated special fabric</li> <li>- Knitted cuffs with thumb loops</li> <li>- Moisture barrier in jacket and sleeve hem</li> <li>- Reflective stripes and Velcro straps secured with double stitching to prevent tearing</li> <li>- Inspection opening in jacket hem with Velcro closure</li> <li>- Jacket length in normal size range 85 cm.</li> </ul>	<p>42-68 / S42-S68 / L42-L68</p>	<p>579816414</p>



PERSONAL PROTECTIVE EQUIPMENT





## FIREFIGHTER CLOTHING

Product	Name	Description	Size	Part no.
	<b>Combat jacket WATEX Desert Guard</b>	EN 469:2005, Xf2/Xr2/Y2/Z2, Reflective coating according HuPF Part 1 07/20 with double seam, PSA Cat. III  Highly breathable layer construction, quick-release zipper (panic zipper), pre-shaped sleeve with Kevlar/silicone elbow reinforcement, mounted shoulder padding, knitted cuffs with thumb hole, two inserted chest pockets for radios, napoleon pocket under the front cover strip. Moisture barrier in jacket and sleeve hem, carabiner hook in the left side pocket.	42-66 / S42-S66 / L42-L66  42-66 / S42-S66 / L42-L66	579816405  579819274
	<b>Combat jacket WATEX Desert Guard, segmented</b>	EN 469:2005, Xf2/Xr2/Y2/Z2, Segmented reflective striping according HuPF Part 1 07/20, PPE Cat. III, jacket length 82 cm  Highly breathable layer construction, quick-release zipper (panic zipper), pre-shaped sleeve with Kevlar/silicone elbow reinforcement, mounted shoulder padding, knitted cuffs with thumb hole, two inserted chest pockets for radios, napoleon pocket under the front cover strip. Moisture barrier in jacket and sleeve hem, carabiner hook in the left side pocket.	42-66 / S42-S66 / L42-L66  42-66 / S42-S66 / L42-L66	579819272  579819276
	<b>Combat jacket WATEX Fire-Jack, back letters "FIRE BRIGADE"</b>	EN 11612:2015, EN 15614:2007, PSA-Cat. II, Segmented warning/reflective stripes according HuPF 09/2006, lightweight single-layer construction.  This single-layer jacket is designed for use in forest fires and technical assistance. It features a high collar, a front zipper concealed by a cover strip with Velcro, an upper arm pocket with pen compartments, flap size suitable for placing local badges, elastic waistband on the sides, two attached chest pockets with securing Velcro under the flaps, antenna loops and microphone holders on the back with Velcro for fixing a shoulder patch or name tag, two attached side pockets with top and side access, with flaps and Velcro closures, left pocket with a strap including a carabiner hook, elbow reinforcement made of the same outer fabric, sleeves with Velcro straps for adjusting the width, ergonomic cut, and a drawstring with a stopper in the jacket hem.	42-66 / S42-S66 / L42-L66  42-66 / S42-S66 / L42-L66	579816091  579816092



## FIREFIGHTER CLOTHING

Product	Name	Description	Size	Part no.
	<b>Combat pants WATEX Desert Guard</b>	EN 469:2005, Xf2/Xr2/Y2/Z2, Reflex stripes according HuPF Part 4 with double stitching, PSA Cat. III  Knee reinforcement made of Kevlar/Silicone with padding, shortened hem on the back of the pants, and inserted side pockets. Inspection opening, sturdy and highly flexible suspenders system detachable from the back of the pants with a Velcro system, extra wide strap bands (50 mm wide) in red, with padded shoulder protection made of upper fabric. The strap bands connect with a padded back panel that prevents the suspenders from slipping. Sturdy suspender buckles on the front of the pants.	42-66 / S42-S66 / L42-L66	579819275
	<b>Combat pants WATEX Desert Guard, sand</b>		42-66 / S42-S66 / L42-L66	579816410
	<b>Combat pants WATEX Desert Guard, segmented</b>	EN 469:2005, Xf2/Xr2/Y2/Z2, Segmented warning/ reflection stripes according HuPF Part 4, PSA Cat. III  Knee reinforcement made of Kevlar/Silicone with padding, shortened hem on the back of the pants, and inserted side pockets. Inspection opening, sturdy and highly flexible suspenders system detachable from the back of the pants with a Velcro system, extra wide strap bands (50 mm wide) in red, with padded shoulder protection made of upper fabric. The strap bands connect with a padded back panel that prevents the suspenders from slipping. Sturdy suspender buckles on the front of the pants.	42-66 / S42-S66 / L42-L66  42-66 / S42-S66 / L42-L66	579819277  579819273

## FIREFIGHTER CLOTHING



Product	Name	Description	Size	Part no.
	<b>Combat pants WATEX Fire-Brake</b>	<p>EN 469:2005, Xf2/Xr2/Y2/Z2, Segmented warning and reflective striping according HuPF Part 4, PSA Cat. III</p> <p>Firefighter pants with slightly extended back. Stable and elastic red suspenders, sewn onto the back of the pants, with snap closure at the front. Fly and waistband with Velcro closure and elastic band. Two patch bellow pockets with flaps and Velcro closures, with an additional knife pocket on the right side. Velcro closures for adjusting the width of the legs. Moisture-blocking seals and abrasion-resistant materials at the hems. Inspection opening.</p> <p>Features:</p> <ul style="list-style-type: none"> <li>- Base color dark blue with yellow contrast threads</li> <li>- All reflex stripes and velcro straps are double-stitched to prevent tearing</li> <li>- Two inserted side pockets</li> <li>- Knee insulation is firmly sewn into the knee reinforcement made of silicone-coated special fabric</li> </ul>	42-68 / S42-S68 / L42-L68	579816415
	<b>Trousers WATEX Fire-Jack</b>	<p>EN 11612:2015, EN 15614:2007, PSA-Cat. II, Segmented warning and reflective stripes according HuPF 09/2006 with a detachable suspender system.</p> <p>Designed for use in forest and vegetation fires as well as technical rescue operations. Features detachable suspenders system with quick-release mechanism, a fitted waistband with lateral elastic band, wider cut in the back area, waist closure with snap and Velcro, zipper fly, two inserted side pockets with concealed access, two rear pockets with flap and Velcro closure, 7 belt loops, two patch bellows pockets with flaps and Velcro closure, ergonomic knee reinforcement made of coated para-aramid with firmly sewn padding, abrasion protection at the hem of the trousers, and Velcro closure for adjusting the leg width.</p>	42-66 / S42-S66 / L42-L66	579816093

## FIREFIGHTER CLOTHING

Product	Name	Description	Size	Part no.
	<b>Trousers WATEX Fire-Jack</b>	EN 11612:2015, EN 15614:2007, PSA-Cat. II, Segmented warning and reflective stripes according HuPF 09/2006 standard, detachable suspender system	42-66 / S42-S66 / L42-L66	579816094
	<b>Combat overall WATEX Waldbrand</b>	EN 11612:2015, EN 15614:2007, PSA-Cat. II, Segmented warning/reflection stripes, increased visibility, high-necked stand-up collar  2-way front zipper covered by flap with Velcro closure, two chest pockets with flaps and Velcro closure, microphone loops on right and left sides of collar, upper arm pocket with flap and Velcro closure, sleeve with tab and Velcro closure at hem, two pockets on back with elasticated opening for water bottles, two thigh pockets with zippered opening, elastic waistband, ventilation opening with zipper below armpit on torso and on back of thigh, knee reinforcement made of coated Kevlar fabric with padding, side seam at leg hem with zipper for easy donning	42/44-66/68	579816095

PERSONAL PROTECTIVE EQUIPMENT

## FIREFIGHTER CLOTHING

Product	Name	Description	Colour	Part no.
<b>ACCESSORIES</b>				
	<b>Dönges clothing bag</b>	In order to prevent the spread of contamination, the emergency personnel can undress on the open bag, take off their protective clothing and pack it. This is easy to handle as the bag can be opened almost completely, including the bottom, with a zipper.		579808891
	<b>High visibility vest</b>	EN ISO 20471 Class 2 (Successor EN 471). Fully retroreflective stripes all around. Polyester.  As above, cotton.	orange	579807810
			orange	579804738
	<b>High visibility vest</b>	According EN ISO 20471, Class 2, without print, with 2 reflective strips all around.	yellow	579804481





## FIREFIGHTER CLOTHING

Product	Name	Description	Colour	Part no.
	<p><b>Dönges Identification vest</b></p>	<p>The Dönges identification vest is truly a functional vest. Thanks to many detailed solutions, the vest offers much more than the actual task of marking the function of its user.</p> <p>For a lot of equipment:</p> <p>There is plenty of space for equipment in the generous pockets. Whether writing pad, radio, lamp, knife or mobile phone - everything can be conveniently stowed away here. Many loops to secure the equipment and attach a headset.</p> <p>Adjustment:</p> <p>Thanks to hook and loop adjustment on the side, the width of the vest can be adjusted. So, it always fits perfectly which reduces the risk to get caught unintentionally.</p> <p>Name and function labels can be attached to the fleece areas on the chest and back.</p> <p>Features:</p> <ul style="list-style-type: none"> <li>- Universal size, adjustable in width with Velcro on the sides</li> <li>- Hook-and-loop patches on the chest, left and right, each measuring 13 x 5 cm</li> <li>- Double hook-and-loop patch on the back for attaching two Velcro patches (each 38 x 8 cm)</li> <li>- Yellow-silver-yellow segmented reflective strips for better visibility</li> <li>- Two front pockets with Velcro closure, located on the sides, measuring 15 x 16 x 3 cm (H x W x D)</li> <li>- Two chest pockets for equipment with Velcro closure, measuring 20 x 9 x 6 cm (H x W x D)</li> <li>- Chest pockets can be adjusted in size with Velcro, additional holding loop and D-ring for securing equipment</li> </ul> <p>Any accessories in the product photos are for illustration purposes only and are not included in the scope of delivery. The vest is supplied without accessories.</p>	<p>blue</p>	<p>579810003</p>

## FIREFIGHTER CLOTHING

Product	Name	Description	Colour	Part no.
	<b>Dönges Identification vest</b>	<p>Features:</p> <ul style="list-style-type: none"> <li>- Universal size, adjustable via Velcro on the sides</li> <li>- Fleece surfaces on the chest, left and right, each 13 x 5 cm</li> <li>- Double fleece surface on the back for attaching two Velcro patches (each 38 x 8 cm)</li> <li>- Reflective yellow-silver-yellow stripes for better visibility</li> <li>- Two patch pockets with Velcro closure on the front sides, 15 x 16 x 3 cm (H x W x D)</li> <li>- Two chest pockets for equipment with Velcro closure, 20 x 9 x 6 cm (H x W x D)</li> <li>- Inner chest pockets can be reduced in size via Velcro, additional holding loop and D-ring for securing equipment</li> <li>- Holding loops for communication headset in the shoulder area</li> </ul>	green	579810004
	<b>Dönges Identification vest</b>	<p>Any accessories in the product photos are for illustration purposes only and are not included in the scope of delivery. The vest is supplied without accessories.</p>	yellow	579810005
	<b>Dönges Identification vest</b>		black/ white, checkered	579815947
	<b>Dönges Identification vest</b>		white	579816221

## FIREFIGHTER CLOTHING





Product	Name	Description	Colour	Part no.
	<b>Dönges Identification vest</b>	<p>Features:</p> <ul style="list-style-type: none"> <li>- Universal size, adjustable via Velcro on the sides</li> <li>- Fleece surfaces on the left and right chest, each measuring 13 x 5 cm</li> <li>- Double fleece surface on the back for attaching two Velcro patches (each measuring 38 x 8 cm)</li> <li>- Yellow-silver-yellow reflective stripes for better visibility</li> <li>- Two patch pockets on the front sides with Velcro closure, measuring 15 x 16 x 3 cm (H x W x D)</li> <li>- Two chest pockets for equipment with Velcro closure, measuring 20 x 9 x 6 cm (H x W x D)</li> <li>- Inner chest pockets can be reduced in size via Velcro, with additional holding loop and D-ring for securing equipment</li> <li>- Holding loops for communication headset in the shoulder area</li> </ul>	red	579816222
	<b>Dönges Identification vest</b>	<p>Any accessories in the product photos are for illustration purposes only and are not included in the scope of delivery. The vest is supplied without accessories.</p>	purple	579816223
	<b>Reflective sign for identification vest 38x8 cm</b>		High visibility yellow	579815919
without image	<b>Set of signs</b>	Customized print (black) according to customer specifications, sign colour: Yellow		579806769
	<b>Standby bag for High visibility vest</b>			579808391



## PROTECTIVE CLOTHING



Product	Name	Description	Size	Part no.
	<b>Chemical protection suit CPS 5900</b>	Lightweight and gas-tight for single use: only provides protection against industrial chemicals and warfare agents.	S M L XL XXL	579801521 579801522 579801523 579801524 579801525
	<b>Chemical protection suit CPS 7900</b>	Gas-tight, reusable. Outstanding protection against chemicals, chemical warfare agents, and other hazardous substances. Certification EN 943.	S M L XL XXL	579801526 579801527 579801528 579801529 579801530
	<b>Chemical protection overall</b>	Safety classification PSA Category III, Type 3/4/5+6, Liquid-tight, zipper with double adhesive cover.	M L XL XXL XXXL	579802857 579802858 579802859 579802860 579802861
	<b>Chemical protection overall Tychem® F</b>	Meets the requirements of EN 14126, Cat. III, Type 3/4/5/6, protection against numerous inorganic chemicals, biological and organic hazards, as well as contamination by radioactive particles.	XL XXL	579804851 579805205

**PROTECTIVE CLOTHING**



Product	Name	Description	Colour	Part no.
	<b>Heat-protective poncho</b>	Heat-protective clothing 14530/cape poncho with gloves and packing bag. Material: aluminized glass	silver	579800011
	<b>Heat-protective coat</b>	Heat-protective clothing FORM II. Material: aluminized glass. Suitable for fire brigade helmet up to Gallet F1.	silver	579800012
	<b>Heat-protective suit 2000</b>	DIN EN 1486:2008-04, fixed hood suitable for various helmets, adjustable suspenders, heat-protective boots, gloves, including packing bag.	silver	579800014
	<b>Heat-protective suit 2500</b>	DIN EN 1486:2008-04, fixed hood suitable for various helmets, adjustable suspenders, heat-protective boots, gloves, including packing bag.	silver	579800015

PERSONAL PROTECTIVE EQUIPMENT

## PROTECTIVE CLOTHING



Product	Name	Description	Size	Part no.
	<b>Heat-protective suit 5500</b>	DIN EN 1486:2008-04, fixed overshoes with galoshes, gauntlet gloves, detachable helmet fits with all types of mask straps, silver		579800018
without image	<b>Oil cleanup – Protective jacket ISOPANT</b>	For use in oil spills and pipeline work with a risk of liquids catching fire. Resistant to acids and alkalis, permanently waterproof and windproof. Smooth-fitting without pockets, with a lapel collar and concealed zipper. Ball sleeves with elastic cuffs. Surface resistance at 5 x 108Ω. Certified to EN 531, EN 467, EN 343. PPE category III.	up to incl. size 54	579800020
			up to incl. 56-60	579800021
without image	<b>Oil cleanup – Protective overall ISOPANT</b>	For use in oil spills and pipeline work with a risk of liquids catching fire. Resistant to acids and alkalis, permanently waterproof and windproof. Adjustable waist, elastic and adjustable suspenders, leg ends with elastic cuffs, chest bib with attached pocket, no side pockets but with pass-throughs. Surface resistance at 5 x 108Ω. Certified according to EN 531, EN 467, EN 343. PSA Category III	up to incl. size 54	579800022
			of size 56-60	579800023
	<b>Oil cleanup – Protective combination suit ISOPANT</b>	For use in oil spills and pipeline work with a risk of liquids catching fire. Resistant to acids and alkalis, permanently waterproof and windproof. Collar with lapels and concealed zipper, ball sleeves and elastic cuffs at the ankles, ventilation slots under the arms, belt with quick-release buckle. Without pockets, without pass-throughs. Surface resistance of 5 x 108Ω. Certified according to EN 531, EN 467, EN 343. PSA Category III	50/52 (S)	579800024
			54/56 (M)	579800025
			58/60 (L)	579800026
without image	<b>Oil cleanup – Protective hood ISOPANT</b>	With vest attachment and five-finger gloves, suitable for EN protective helmet		579800027
without image	<b>Packing bag ISOPANT®</b>	Pack bag for ISOPANT(R) equipment complete with boots.		579800031

## PROTECTIVE CLOTHING



Product	Name	Description	Size	Part no.
	<b>Husqvarna Technical Waist trousers 20A</b>	KWF certified, according EN 381 Class 1 (20 m /s), all-around leg protection, Reinforcement on knees	S M L XL XXL	579816786 579816787 579816788 579816789 579816790
	<b>Husqvarna Technical Overall 20A</b>	KWF certified, according EN 381 Class 1 (20 m/s), all-around leg protection, reinforcement on lower leg, ventilation zippers on back of legs	S M L XL XXL	579816792 579816794 579816795 579816797 579816798
	<b>Husqvarna Forest jacket Technical Arbor 20</b>	according EN 381 Class 1 (20 m/s), Velcro for hook and loop adjustment at end of sleeves, cut protection in chest, shoulder, arm and stomach area.	S M L XL	579816800 579816803 579816804 579816805

PERSONAL PROTECTIVE EQUIPMENT

## PROTECTIVE CLOTHING

Product	Name	Description	Size	Part no.
	<b>Forestry work trousers Stihl Dynamic</b>	DIN EN 381-5:1995-06, Class 1, Design C (all-around leg protection), knee areas double reinforced	S M L XL XXL	579801791 579801792 579801793 579801794 579801795
	<b>Cut protection and high-visibility jacket Stihl Protect MS</b>	EN 381, Protection class 1 = 20 m/s, Design A, cut protection in chest, shoulder, arm and stomach area	S M L XL XXL	579807357 579807358 579807356 579807359 579807360
	<b>Forestry work overall Basic Design C</b>	EN 381 Part 5 Design C Class 1, cut-resistant lining in legs, elastic, adjustable suspenders	54 56 58 60 62 64	579816779 579815563 579816758 579809814 579816780 579816781
	<b>Forestry work protec- tion jacket - Forest Jack</b>	EN 381-11 Class 1, Upper arm area highlighted in warning color, cut-resistant lining in sleeve and upper body area	54 56 58 60 62 64	579816782 579815562 579816783 579815561 579816784 579816785

**PROTECTIVE CLOTHING**

Product	Name	Description	Size	Part no.
	<b>Cut protection and high-visibility overall, Forest Jack</b>	Description: EN 381-5, Class 1, Design C, KWF certified, cut-resistant lining in legs	54 56 58 60 62 64	579808203 579806530 579807108 579805580 579809619 579807109
	<b>Cut protection and high-visibility jacket, Forest Jack</b>	EN 381-11, Class 1, Cut-resistant lining in sleeve and chest area (front and back)	54 56 58 60 62 64	579808204 579808206 579807110 579806152 579809620 579807111
	<b>Cut protection all-around leg Klassik</b>	EN 381-5 Class 1, KWF certified (K-EG-2006/4361, K-EG-4389/5780), Form C, 9 layers Cut protection PES/PP	One size	579804416

PERSONAL PROTECTIVE EQUIPMENT

## GLOVES

Product	Name	Description	Size	Part no.
	<b>Husqvarna Cut-protection Gloves Technical</b>	EN ISO 11393 Class 1 (20 m/s), Cat. II according EN 388, palm made of durable, naturally water-resistant, index finger has a touch screen-friendly knuckle so you can use your smartphone with your gloves on	8 9 10	579816808 579816811 579816812
	<b>Cut-protection Gloves Stihl Dynamic</b>	DIN EN 381-7, Form A, Protection class Class 1 (20 m/s), Schutzeinlage in beiden Handrücken	8 9 10 11	579801827 579801828 579801829 579801830
	<b>Cut-protection Gloves Stihl FUNCTION Pro- tect MS</b>	EN 381-7, Protection class Class 0 (16 m/s), Protec- tive insert in both backs of the hand	8 9 10 11	579808477 579805029 579805030 579805031
	<b>Fire brigade glove THL 5</b>	EN 388, EN 420, anatomical fit, highest tactility and cut protection	7 8 9 10 11 12	579808317 579808318 579808319 579808320 579808321 579808322
	<b>Gloves Askö Split Rescue</b>	EN 388, Reinforcements made of heat-resistant split leather on the palm, providing protection and thermal insulation against contact heat according to EN 407	7 8 9 10 11 12	579805927 579805928 579805607 579805608 579805610 579805611
	<b>Fire brigade gloves Seiz ONE-4- ALL</b>	EN659:2003+A1:2008+AC:2009, All-purpose glove, cut protection class level 4 out of 5, waterproof.	7 8 9 10 11	579816845 579816846 579816847 579816848 579816849

## GLOVES

Product	Name	Description	Size	Part no.
	<b>Fire brigade gloves Seiz Fire-Fighter Evolution</b>	EN 659:2003 + A1:2008 + AC:2009, Level 4 of 5, Cut resistance according ISO 13997 - Level D, waterproof, long	7 8 9 10 11	579816816 579816817 579816818 579816819 579816820
	<b>Fire brigade gloves Seiz Fire-Fighter ZIP (FF ZIP)</b>	EN659:2003+A1:2008+AC:2009, Level 3 of 5, Cut resistance according ISO13997-Level C, waterproof, short, with ZIP`N`CLOSE-System	7 8 9 10 11	579816830 579816831 579816832 579816833 579816834
	<b>Fire brigade gloves Seiz Fire-Fighter Anatomic</b>	EN 659:2003 + A1:2008 + AC:2009, Level 4 of 5, Cut resistance according ISO 13997 - Level E, waterproof, long	7 8 9 10 11	579816835 579816836 579816837 579816838 579816839
	<b>Fire brigade gloves Seiz Thermo- Fighter</b>	EN659:2003+A1:2008+AC:2009, Level 3 of 5, Cut resistance according ISO13997-Level C, waterproof, Heat-resistant, impregnated Special leather	7 8 9 10 11	579816840 579816841 579816842 579816843 579816844
	<b>Fire brigade gloves Seiz® Supersoft</b>	DIN EN 659:2008-06, waterproof and breathable, Cuff made of heat-resistant and impregnated special leather, 3M reflective stripes	7 8 9 10 11	579804347 579804346 579804345 579804128 579804860





PERSONAL PROTECTIVE EQUIPMENT



## GLOVES

Product	Name	Description	Size	Part no.
	<b>Fire brigade gloves Seiz "Fire-Fighter Premium"</b>	DIN EN 659:2008-06, Seiz® Heat Absorber, double closure system, 3M Reflective stripes	7 8 9 10 11	579804344 579804343 579804342 579804127 579808008
	<b>Working gloves</b>	Made of pigskin leather, lined palm, canvas cuff. Protection class 1	10	579802888
	<b>Chemical protection gloves Sol-Knit®</b>	EN388, EN374, EN407, Category 3, rough texture, carrier material cotton.	9 10 11	579805694 579802855 579805695
	<b>Single-use Gloves Latex</b>	Powder-free, with rolled edge, seamless shape. Reversible for wearing on either side.	M L XL	579805646 579802862 579804377
	<b>Single-use Gloves Nitril</b>	PSA-Category 3, EN 374, EN 388, EN 1186, Powder-free.	M L XL XXL	579815475 579815476 579815477 579815939

## BOOTS

Product	Name	Description	Size	Part no.
	<b>Safety boots "Heavy Duty" S5</b>	EN 345 S5, Slip-resistant sole, oil and acid resistant, antistatic, 38 cm shaft.	40 41 42 43 44 45 46 47	579802847 579802848 579802849 579802850 579802851 579802852 579802853 579802854
	<b>Shaft boots NBR</b>	DIN EN 15090:2006-10, Category F3A, EN 20345 S5 PHRO, 37 cm	37/38 39 40/41 42 43 44 45 46/47 48 49/50	579804543 579804544 579804545 579804546 579804547 579804548 579804549 579804550 579804551 579804552
	<b>Laced boots Primus 21 SP</b>	EN ISO 15090:2012 F2A AN CI HI3 SRC. Oil, petrol, and acid resistant. Slip resistance SRC, shaft height 23 cm.	41 42 43 44 45 46	579804138 579804339 579804340 579804341 579804861 579807620
	<b>Chest wader with safety boots S5</b>	Adjustable straps, welded boots S5 with reinforcement ribs.	40 41 42 43 44 45 46 47	579802864 579802865 579802866 579802867 579802868 579802869 579802870 579806619
	<b>Chest wader army design</b>	EN ISO 20345 SRA, according TL 8415-157, with Safety boots S5, fabric is coated with PVC on both sides	40 41 42 43 44 45 46 47	579807618 579807617 579806582 579807616 579805876 579806583 579804900 579807619

PERSONAL PROTECTIVE EQUIPMENT

# MAXIMUM PRECISION AND ERGONOMY IN USE

The Next Generation of Turntable Ladders with Magirus SmartControl

The new generation of Magirus turntable ladders with SmartControl represents a groundbreaking user-friendliness, precise control and ergonomic operation of turntable ladders. The solution not only stands for networked control, but also supports emergency services with smart, automated functions and a great variety of camera views - individually adjustable and streamable. Thus, the turntable ladder can be controlled safely and with unrivalled precision. Experience the firefighting technology of the future that is already available today!



More  
about  
Smart  
Control



NEXT GENERATION FIREFIGHTING

# MAXIMUM PROTECTION: THE FIRE BRIGADE HELMET MAGIRUS PROTECTUS P1

The Magirus Protectus P1 helmet is an excellent choice for firefighting in both indoor and outdoor situations. Our new full-shell helmet, Type B/3b, provides maximum protection during all operations, as it can withstand extreme temperatures and high mechanical stress. Thanks to its ergonomic neck area, it offers firefighters greater mobility and less strain on their spine.

The Magirus Protectus P1 also stands out for its one helmet size, lightweight design, and perfect fit. All components of the helmet have been extensively tested for practicality. The helmet also allows for the integration of communication systems into the head spider.

## DESIGNED FOR CHALLENGING DEPLOYMENTS

Firefighting operations push humans and equipment to their limits. Therefore, the Magirus Protectus P1 helmet complies with all current standards such as EN 443:2008, EN 16471, and EN 16473. The Magirus Protectus P1 is made of thermoplastic high-temperature material, which is formed into its ergonomic shape through precise manufacturing processes. This provides high strength and impact resistance under extreme conditions during operations.

## LIGHT AND ROBUST

The adjustable axes allow for perfect balancing of the center of gravity in the helmet and ensure comfortable and fatigue-free work for firefighters. The innovative design of the helmet shell enables maximum protection against lateral deformations.







#### AVAILABLE COLOURS



#### HIGHLIGHTS

- **FRONT PLATE:** Interchangeable front plate that can be equipped with the logo of the fire brigade or a helmet lamp
- **VISOR:** Class 1 for better visibility and longer wearing comfort – also available in tinted gold
- **MASK ADAPTOR:** User-friendly design that allows all common respiratory protection masks to be attached
- **ADJUSTMENT WHEEL:** Integrated low-profile adjustment wheel that can be easily operated with gloves
- **ACCESSORIES:** Interchangeable cover for adaptor to accommodate accessories such as a second helmet lamp, thermal imaging camera

**MAGIRUS PROTECTUS P1**

Product	Name	Description	Colour	Part no.
	<b>Magirus Fire brigade helmet</b>	Visor transparent	chrome	579818302
		Visor transparent Eye visor transparent		579818409
		Visor transparent Eye visor tinted		579818410
		Visor gold		579818411
		Visor gold Eye visor transparent		579818412
		Visor gold Eye visor tinted		579818413
	<b>Magirus Fire brigade helmet</b>	Visor transparent	red	579818414
		Visor transparent Eye visor transparent		579818415
		Visor transparent Eye visor tinted		579818416
	<b>Magirus Fire brigade helmet</b>	Visor transparent	yellow	579818417
		Visor transparent Eye visor transparent		579818418
		Visor transparent Eye visor tinted		579818419
	<b>Magirus Fire brigade helmet</b>	Visor transparent	noctilucant	579818420
		Visor transparent Eye visor transparent		579818421
		Visor transparent Eye visor tinted		579818422
	<b>Magirus Fire brigade helmet</b>	Visor transparent	luminous	579818423
		Visor transparent Eye visor transparent		579818424
		Visor transparent Eye visor tinted		579818425

PERSONAL PROTECTIVE EQUIPMENT

## MAGIRUS PROTECTUS P1



Product	Name	Description	Colour	Part no.
	<b>Magirus Fire brigade helmet</b>	Visor transparent	blue	579818426
		Visor transparent Eye visor transparent		579818427
		Visor transparent Eye visor tinted		579818428
	<b>Magirus Fire brigade helmet</b>	Visor transparent	green	579818429
		Visor transparent Eye visor transparent		579818430
		Visor transparent Eye visor tinted		579818431
	<b>Magirus Fire brigade helmet</b>	Visor transparent	black	579818433
		Visor transparent Eye visor transparent		579818434
		Visor transparent Eye visor tinted		579818435
	<b>Magirus Fire brigade helmet</b>	Visor transparent	silver	579818436
		Visor transparent Eye visor transparent		579818437
		Visor transparent Eye visor tinted		579818438
	<b>Magirus Fire brigade helmet</b>	Visor transparent	white	579818440
		Visor transparent Eye visor transparent		579818441
		Visor transparent Eye visor tinted		579818442

## ACCESSORIES MAGIRUS PROTECTUS P1

Product	Name	Description	Weight (kg)	Part no.
without image	<b>Sticker Kit</b>	Replacement part		579818443
without image	<b>Sticker Kit</b>	Replacement part		579818444
	<b>Eye visor transparent</b>	to retrofit existing Protectus P1. Scope of delivery: Visor, Assembly material		579818445
	<b>Eye visor tinted</b>	to retrofit existing Protectus P1. Scope of delivery: Visor, Assembly material		579818446
without image	<b>Visor transparent</b>	Replacement part		579818447
	<b>Visor gold</b>	Replacement part		579818448
	<b>Neck protection NOMEX</b>	to retrofit existing Protectus P1		579818449
without image	<b>Neck protection Aluminium</b>	to retrofit existing Protectus P1		579818450
	<b>Adaptor right</b>	Replacement part		579818451
	<b>Adaptor left</b>	Replacement part		579818452
	<b>Hand-held lamp 3315Z0 LED</b>	IP67, ATEX-Zone 0, 138 Lumen, Push Button, Illumination mode ON/OFF, Battery type AA (3x)	0,18	579818100





## ACCESSORIES MAGIRUS PROTECTUS P1

Product	Name	Description	Weight (kg)	Part no.
	<b>Helmet-Com Headset Savox HC-200</b>	with Nexus plug to connect to C-C440 or RSM C-C550 with dual microphone and helm adaptor		579817798
	<b>Savox C-C440/M7-3</b>	for MTP6000, MTP6550		579817799
	<b>Speaker microphone Savox C-C550/M7-2</b>	Push-To-Talk with Headset connection, spiral cable, 2 big PTT keys, IP67, for Headsets with 4-pin quick-disconnect connector		579817800





## HELMETS

Product	Name	Description	Colour	Part no.
	<b>Forest helmet Husqvarna Technical</b>	EN 352, EN 397, EN 1731, kwf certified, very lightweight and stable, individually adjustable and ventilated with an innovative system		579816865
	<b>Forest helmet Husqvarna Functional</b>	EN 352, EN 397, EN 1731, Mesh visor, ear protection adjustable laterally and vertically		579807990
	<b>Helmet set Stihl FUNCTION Basic</b>	EN 352, EN 397, EN 1731, Lightweight helmet set with a large visor and ventilation openings on both sides.		579806950
	<b>Helmet set Stihl Advance Nylon</b>	EN 352, EN 397, EN 1731, Integrated rain channel, intelligent visor swivel system.		579806870
	<b>Helmet set Stihl FUNCTION Universal</b>	EN 352, EN 397, EN 1731, Lightweight helmet set with large visor and ventilation openings on both sides.		579808433
	<b>Helmet set Stihl DYNAMIC Ergo</b>	EN 352, EN 397, EN 1731, Lightweight helmet set with a large visor and ventilation openings in the upper area.		579808434

## HELMETS

Product	Name	Description	Colour	Part no.
	<b>Helmet set Stihl DYNAMIC X-Ergo</b>	EN 352, EN 397, EN 1731, Optimized helmet set with large metal mesh visor and ventilation openings in the upper area.		579808435
	<b>Helmet set Stihl ADVANCE Vent</b>	EN 352, EN 397, EN 1731, Helmet set with a large metal mesh visor and ventilation openings distributed over the entire helmet shell.		579808436
	<b>Helmet set Stihl ADVANCE X-Vent</b>	EN 352, EN 397, EN 1731, Helmet set with large spring steel mesh visor and ventilation openings distributed over the entire helmet shell.		579808437
	<b>Forestry work helmet 3M, Dönges</b>	EN 397. Ear muffs EN 352-3. Face protection EN 1731. Sun/rain protection. With UV indicator.		579802856
	<b>Integrated protection glasses Stihl</b>	For Helmet sets ADVANCE Vent and ADVANCE X-Vent.		579808438
	<b>Protection goggles uvex ultrasonic 9302</b>	Full-face goggles with transparent lenses, transparent. UV 400, 2-1.2 W I B9 KN DIN CE.		579808600

STRAPS



Product	Name	Description	Part no.
	<b>Fire brigade strap Type A</b>	with Twist lock, Size 1, holes of two-prong buckle are reinforced with metal eyelets. as above, Size 2 as above, Size 3 as above, Size 4	579815606  579815607 579815608 579815609
	<b>Fire brigade strap Type B</b>	with Twist lock, Size 1, holes of two-prong buckle are reinforced with leather. as above, Size 2 as above, Size 3 as above, Size 4  with twist lock mechanism, Size 1, holes of two-prong buckle are reinforced with leather. as above, Size 2 as above, Size 3 as above, Size 4	579802879  579802880 579802881 579802882  579802883  579802884 579802885 579802886
	<b>Fire brigade strap Artex Type FHA</b>	Size 1, EN 358, DIN 14927:2015-05, Carabiner with screw lock and multifunctional loop. as above, Size 2 as above, Size 3 as above, Size 4	579806154  579806155 579806156 579806157
	<b>Fire brigade strap Artex Type FHB</b>	Size 1, Twist lock mechanism, without redirection, reinforced with leather. as above, Size 2 as above, Size 3 as above, Size 4	579808334  579808336 579808337 579808338

PERSONAL PROTECTIVE EQUIPMENT

# WILDLAND FIREFIGHTING EQUIPMENT







## FIREFIGHTER HELMETS

Product	Name	Description	Colour	Part no.
	<b>Firefighter helmet vft1 (RAL 1023)</b>	<p>The vft 1 helmet was developed to meet the requirements of emergency personnel involved in vegetation fire suppression and technical assistance. It is made from high-quality materials and provides a high level of protection with a protective visor and an ear protection rim specially designed to protect the ears. The vft 1 is a comfortable and versatile helmet that can be equipped with a range of accessories.</p> <p>External features: The helmet is made of PC/ABS and features ventilation, goggles attachment, headlight attachment clips, flashlight attachment, foldable face shield, and clearing grid. Additionally, hearing protection, neck protection, and integrated radio and video systems can be incorporated.</p> <p>Internal features: The internal strap comes in multiple sizes (XS to XL) and is adjusted using a strap band. Together with the breathable padded fabric, it forms a completely ergonomic and comfortable strap.</p> <p>Norms: EN 16471/14, EN 16473/14, EN 12482/12, EN 397:2012+A1:2012, EN 443/08</p>	yellow	579817272
	<b>Firefighter helmet vft1, (RAL 1026)</b>		bright yellow	579817273
	<b>Firefighter helmet vft1, (RAL 2008)</b>		orange	579817274
	<b>Firefighter helmet vft1, (RAL 2008)</b>		bright orange	579817276

WILDLAND FIREFIGHTING EQUIPMENT

## FIREFIGHTER HELMETS

Product	Name	Description	Colour	Part no.
	<b>Firefighter helmet vft1, (RAL 3020)</b>		red	579817277
	<b>Firefighter helmet vft1, (RAL 9003)</b>		white	579817278
	<b>Firefighter helmet vft1, (RAL 5017)</b>		blue	579817279
	<b>Firefighter helmet vft1, (RAL 6018)</b>		green	579817280
	<b>Firefighter helmet vft1, (RAL 9005)</b>		black	579817281

## FIREFIGHTER HELMETS





Product	Name	Description	Colour	Part no.
	<b>Firefighter helmet vft2 Yellow (RAL 1023)</b>	<p>The new vft2 firefighting helmet for forest fires has been designed with the aim of meeting the requirements of emergency personnel during forest fire incidents.</p> <p>External features: The helmet is made of ABS/PC and features ventilation, goggles attachment, headlight attachment clips, flashlight attachment, and a foldable protective grid. Additionally, hearing protection, neck protection, and integrated radio and video systems can be incorporated.</p> <p>Internal features: The internal strap is made of EPS and comes in multiple sizes (XS to XL). Its function is to distribute the impact forces. It is adjusted using a strap band and, together with the breathable padded fabric, forms a completely ergonomic and comfortable strap.</p> <p>Norms: EN 16471/14, EN 16473/14, EN 12492/12, EN 397: 2012 + A1: 2012, EN 443/08</p>	yellow	579817282
	<b>Firefighter helmet vft2 Orange (RAL 2008)</b>		orange	579817283
	<b>Firefighter helmet vft2 Red (RAL 3020)</b>		red	579817284
	<b>Firefighter helmet vft2 White (RAL 9003)</b>		white	579817285



## FIREFIGHTER HELMETS







Product	Name	Description	Colour	Part no.
	<b>Firefighter helmet vft2 Blue (RAL 5017)</b>		blue	579817286
	<b>Firefighter helmet vft2 Green (RAL 6018)</b>		green	579817287
	<b>Firefighter helmet vft2 Black (RAL9005)</b>		black	579817288
without image	<b>Firefighter helmet vft2, Dove</b>		grey	579817289

## ACCESSORIES FIREFIGHTER HELMETS



Product	Name	Description	Colour	Part no.
	<b>Holder for vft1</b>			579817300
	<b>Holder for Kit - vft2/3 Helmet</b>			579817301
	<b>Flashlight holder vft1</b>			579817302
without image	<b>Holder Helmet lamp for vft1</b>			579817303
	<b>Picatinny Rail Adapter vft1</b>	The Picatinny rail adapter provides a simple and fast attachment system for most accessory components used in forest fire suppression and rescue operations. Can be easily attached to protective helmets.		579817304

WILDLAND FIREFIGHTING EQUIPMENT



## ACCESSORIES FIREFIGHTER HELMETS

Product	Name	Description	Colour	Part no.
	<b>Picatinny Kit vft2-vft3</b>			579817305
	<b>vft1 ventilated protection goggles</b>	Made from high-quality materials that ensure the necessary protection even under the most extreme conditions.		579817306
	<b>Vft Helmet bag</b>	You can conveniently and securely store the helmet and all accessory parts in the storage and transport bag.		579817310
	<b>Polycarbonate protective visor 2 mm vft1</b>	Only for vft1 Helmets		579817316
	<b>Fire brigade protective goggles vft1</b>	Made from high-quality materials that ensure the necessary protection even under the most extreme conditions.		579817321
	<b>Univet Protective goggles 611K01001 black</b>	Double polycarbonate lenses with an anti-fog and scratch-resistant coating. Made from high-quality materials, the protective goggles provide the necessary protection under the toughest conditions.		579817322

## ACCESSORIES FIREFIGHTER HELMETS

Product	Name	Description	Size	Part no.
	<b>VFT Protective mask + Filter</b>	FFP3 particle filters and fastening straps included in scope of delivery		579817324
	<b>VFT Protective mask (without filter)</b>	Fastening straps included in scope of delivery		579817325
	<b>Xtreme Mask + P3 R filter (Particle)</b>	Consists of a textile mask, inner half-mask, 2 P3 R filters (particle filters), and fastening straps		579817326
	<b>vft Neck cover</b>	EN ISO 11612/15, EN 15614/07, EN ISO 13688/13. The VFT neck cover is compatible with any protective helmet.		579817328





## WILDLAND FIRE GEAR

Product	Name	Description	Size	Part no.
	<b>Wildland Firefighter Jacket 1 Layer + Inner lining - Yellow</b>	<p>Wildland firefighting jacket with inner lining for high protection against direct attacks.</p> <ul style="list-style-type: none"> <li>- 4 easy-to-open front pockets for gloves, one of which is for portable radios</li> <li>- Interior pocket with a waterproof membrane for documents</li> <li>- Chest identification patch with Velcro closure</li> <li>- Shoulder-mounted attachment ring for radio harnesses</li> <li>- Adjustable cuffs: inner elastic cuff and outer cuff with Velcro closure</li> <li>- Raised collar at the back for neck protection Adjustable collar flap with Velcro closure</li> <li>- Retention system for the Vallfrest mask</li> <li>- Quick-closing safety zipper in the centre with an easy-opening system</li> <li>- Fabric made of three-layered 265 g/cm<sup>3</sup> NOMEX and VISCOSE-FR fibres for perfect insulation against heat and radiation for the wearer, with NOMEX seams and reflective strips for high visibility. EN 15614 certified</li> <li>- Lining material: Flame-resistant 100% cotton</li> <li>- Composition: Lenzing F.R. 65%   Nomex 30%   Kevlar 5%</li> <li>- Lining weight: 260 g/m<sup>2</sup></li> <li>- Jacket weight: 270 g/m<sup>2</sup></li> <li>- Personal Protective Equipment (PPE) category: III</li> </ul>	XS	579817332
			S	579817333
			M	579817334
			L	579817335
			XL	579817336
			XXL	579817337
			3XL	579817338
	<b>Wildland Firefighter Pants 1 Layer + Inner lining - Green</b>	<p>Flame-resistant wildland firefighting pants with inner lining for high protection against direct attacks.</p> <ul style="list-style-type: none"> <li>- 6 pockets in total. Double knee-side pocket with flap, two slanted front pockets of the French type, and two back pockets</li> <li>- The buckle has a width of 40 mm, made with double fabric</li> <li>- 5 loops for threading a wide belt</li> <li>- Front closure with button and zipper</li> <li>- Adjustment through Velcro closure at the back of the pants</li> <li>- Double reflective bands for high visibility on both legs below the knee</li> <li>- Front layer with inner lining for better protection and a breathable rear layer for improved breathability</li> <li>- Lining material: Flame-resistant 100% cotton</li> <li>- Lining weight: 260 g/m<sup>2</sup></li> <li>- Pants weight: 270 g/m<sup>2</sup></li> <li>- Fabric composition: Lenzing F.R. 65%   Nomex 30%   Kevlar 5%</li> </ul>	XS	579817340
			S	579817341
			M	579817343
			L	579817344
			XL	579817345
			XXL	579817346
			3XL	579817347





## WILDLAND FIRE GEAR

Product	Name	Description	Size	Part no.
	<b>Wildland Firefighter Overall vft Hi-Viz</b>	<p>Entire firefighting fire brigade suit with high visibility, fire-resistant, and three-color design. Provides the highest protection against flames, abrasions, and tears during operations in forest areas. Inner lining made of flame-resistant treated cotton for maximum protection and breathability.</p> <ul style="list-style-type: none"> <li>- 2 chest pockets and 2 hip pockets, all with hidden zippers, concealed by an oversized lapel for easy opening with gloves</li> <li>- Adjustable cuffs with Velcro closure</li> <li>- High collar at the back for neck protection</li> <li>- Adjustable lapel with Velcro closure for neck protection</li> <li>- Adjustment through Velcro closure at the hem of the pants</li> <li>- Central, quick-opening safety zipper and easy opening system, completely concealed with a lapel</li> <li>- Horizontal silver reflective bands on the chest, waist, forearms, and ankles</li> <li>- Inner lining at the front from waist to ankles for maximum radiation protection</li> <li>- Inner lining in elbow area for maximum abrasion protection</li> <li>- Quick opening system with semi-circular zipper in the back area, without having to loosen the upper part</li> <li>- Side opening in pants hem with a zipper, covered by piping. This opening allows the garment's hem to be adjusted to different footwear, making it much more comfortable</li> </ul>	S	579817393
			M	579817394
			L	579817395
			XL	579817396
			XXL	579817397
			3XL	579817398
	<b>vft Wildland Firefighter Gloves</b>	<p>The Fire Brigade Gloves vft provide high protection against radiation, scratches, and cuts. EN 659:2003+A1:2008+AC:2009 certified.</p> <p>Their ergonomic design ensures maximum comfort when working with manual tools, thanks to the independent thumb model that maintains a natural hand position.</p> <p>Specifications:</p> <ul style="list-style-type: none"> <li>- Fire-resistant gloves with five fingers</li> <li>- Outer layer made of leather</li> <li>- Kevlar® lining</li> <li>- Sympatex® membrane on palm and back of the hand</li> <li>- Camel-coloured cuff made of reversed leather with a carabiner hook and yellow reflective band</li> <li>- Closure with a Velcro strap</li> <li>- Ergonomic model with independent thumb</li> <li>- Long version with Velcro closure for maximum radiation protection</li> <li>- Gloves with highest strength</li> </ul>	7	579817380
			8	579817381
			9	579817382
			10	579817383
			11	579817384
			12	579817385

## WILDLAND FIRE GEAR



Product	Name	Description	Size	Part no.
	<b>Firefighter boots vft Xtreme Boots</b>	Boots for wildland fire, EN 15090:2012, protection class F1PA+HI3+CI+SRC, heat-resistant sole up to 300°C	39	579819624
			40	579819625
			41	579819626
			42	579819627
			43	579819628
			44	579819629
			45	579819630
			46	579819631
			47	579819632
			48	579819633
	<b>Xtreme Pack</b>	<p>The Xtreme Pack backpack features an ergonomic, breathable strap system.</p> <p>The design provides full freedom of movement for flexible work with hand tools. The belt includes a 2.8-liter hydration system and the Molle system, allowing for configuration of accessories every user needs. It offers high abrasion, cut, and tear resistance.</p> <p>Made from Cordura 1000D and breathable mesh fabric. Built-in hydration system in the strap. Includes the Hydrapack® system with an external hose and mouthpiece, and a capacity of 2.8 l with a top opening system for easy filling and cleaning. The container is FDA-approved, PVC-free, and BPA-free. Customization for customers. Possibility to attach a shield or logo.</p>		579817399
	<b>Xtreme Pack Personal Pouch</b>	Central pocket where food, maps, and other items can be securely stored and protected against external forces.		579817400
	<b>1L Cover</b>	Side pocket for carrying 1-liter fire torches, water bottles, or personal items.		579817401
	<b>vft Transmitter Holder</b>	Radio pouch for attaching to the backpack using the MOLLE system on the shoulder.		579817402

## ACCESSORIES WILDLAND FIRE GEAR





Product	Name	Description	Part no.
	<b>2.8L HYDRAPAK System + Hydra Fusion Hose 91 cm</b>	Hydrapak® system for storage in the central belt pouch, capacity of 2.8 l. Includes a drinking hose and mouthpiece.	579817403
	<b>Xtreme Shelter XS17</b>	The Xtreme Shelter is equivalent to a fire-resistant blanket that provides protection from direct flame and heat exposure through reflection.	579817404
without image	<b>Xtreme Shelter XS21</b>		579817405
without image	<b>Xtreme Shelter for training</b>		579817406
	<b>Extinguishing backpack vft 20L Orange</b>	The new Vallfirest backpack represents a step forward in terms of professional and ergonomic equipment.	579817410
without image	<b>Water backpack extinguisher tank 17,5l</b>	consists of a start-up pump built into a chromed brass, a 17. 5 l tank and an anti-kink hose.	579819634
	<b>Flexible Extinguisher backpack 18l</b>	Jet:> 8 m, Spraying:> 3 m, Launch volume: 120 cm3/cycle, 100 mm filler neck, with watertight cap	579819635







## ACCESSORIES WILDLAND FIRE GEAR

Product	Name	Description	Part no.
	<b>Hose carrying backpack vft (with bag)</b>	To help fire brigades carry hoses and other heavy loads such as motor pumps, water tanks and other elements needed to extinguish wildland fires.	579816375
	<b>Hose carrying backpack vft (without bag)</b>		579816108

## WILDLAND FIREFIGHTING TOOLS

Product	Name	Description	Part no.
	<b>Multipurpose tools Gorgui Classic</b>	The Gorgui multifunction tool was exclusively designed to combat forest fires.	579817489
	<b>Multipurpose tools Gorgui</b>		579817490
	<b>Transport sheath for Gorgui Classic</b>	Transport sheath for Gorgui, designed for carrying the tool on the back while keeping hands free, with cut protection.	579817491
	<b>Gorgui Carrying bag</b>		579817492
	<b>VFT fire beater</b>	New compact fire beater with an elastic telescopic handle that extends up to 2 m.	579817495

## WILDLAND FIREFIGHTING TOOLS

Product	Name	Description	Part no.
	<b>ALASKA Fire beater</b>	The 45-degree angle in working mode facilitates pressure against the ground and utilizes physical effort more efficiently.	579817496
	<b>Fire rake McLeod- Tool</b>	Sturdy specialized tool for applying wound strips on forest floors. The sharp-edged blade on one side cuts through roots, while the rake effortlessly digs into dry and hard soil. The Nupla fiberglass handle is practically indestructible.	579804285
	<b>Fire brigade axe Pulaski</b>	NUPLA handle nearly indestructible. High-quality forged axe head. Excellent electrical insulation.	579804148
	<b>Fire rake</b>	Very sturdy specialized rake for creating firebreaks on forest floors. Its sharp teeth effortlessly dig into dry and hard soils. The Nupla fiberglass handle is practically indestructible.	579815342
	<b>vft 1L Drip lamp</b>	Drip torches, designed to indirectly attack with technical fire as firewalls, burning out, escape fires, self-protection fires and to create safe zones.	579817497

# HELISKID – WATER, WHENEVER AND WHEREVER YOU NEED IT

“Heliskid” is a compact and versatile fire suppression module designed for small transport vehicles. It is specifically designed for direct fire-fighting operations using hose lines in remote areas. This firefighting module can be transported on the ground or by air and features six times the water capacity of conventional firefighting modules, as well as a built-in high-pressure pump.

## FEATURES

- Quick and easy setup
- Optimized filling time - can be filled using a helicopter
- Water available in hard-to-reach areas through helicopter transport
- Easy to transport on pickups due to its compact size and light weight
- Telescopic legs for loading, unloading, and stabilizing on any terrain

## TECHNICAL DATA

- Available engine power: 13/18/23 HP
- Delivery capacity at 10 bar: 240/355/363 l/min.
- Weight: 350 kg without water / 3350 kg with full tank
- Assembly requires a minimum of 2 persons
- Further information available upon request





**HIGHLIGHTS:**

- Foldable 3000L canvas tank
- 4 lifting points
- 4-stage motor pump with various engines (see next page)
- 12L fuel tank
- Reinforced aluminium main structure
- Telescopic structure

Part no. 579817503

## PORTABLE WATER TANKS

Product	Name	Description	Weight (kg)	Part no.
	<b>Portable water tank 8.000 l</b>	Self-righting made of PVC, incl. Carrying bag and repair kit, tiltable up to 12°, Surface weight: approximately 1400 g/m², Air-fillable buoyancy with 3/8" air connection, equipped with 8 external D-rings at the bottom, includes 4 attachment loops with carabiner hooks. Packing dimension (LxWxH) 900x700x50 mm - without connection fittings	35	579815973
	<b>Portable water tank 10.000 l</b>	Packing dimension (LxWxH) 1000x700x50 mm	45	579809609
	<b>Portable water tank 15.000 l</b>	Packing dimension (LxWxH) 1150x750x60 mm	50	579817977
	<b>Ground sheet 4 x 4 m</b>	for open portable water tank 8000 l	15	579817978
	<b>Ground sheet 5 x 5 m</b>	for open portable water tank 10000 & 15000 l	15	579817979
	<b>Filling and emptying valve A 110 4"</b>	Made of aluminium with brass slider	10	579815481
	<b>Filling and emptying valve B 75 2,5"</b>	Made of aluminium with brass slider	9	579805859
	<b>Filling and emptying valve C 2"</b>	Made of aluminium with brass slider	8	579816916

## EXTINGUISHING MODULE/PORTABLE PUMPS

Product	Name	Description	Length (m)	Part no.
	<b>Heliskid 3000L BH4-13H</b>	The Heliskid is a compact and versatile firefighting module designed for small transport vehicles. It is specifically designed for direct fire attack using hose lines in remote areas.  For more information, please inquire		579817503
without image	<b>Heliskid 3000L BH4-18</b>			579817504
	<b>Heliskid 3000L BH4-23</b>			579817505
	<b>Portable pump BH1</b>	UNE-EN 14466:2006. Portable pump vft Black Hawk 1, the lightweight and robust portable pump is equipped with a single-stage centrifugal pump and a 4-stroke Honda engine, designed for rapid intervention in vegetation fires. It offers a powerful and balanced combination with a maximum pressure of up to 6.9 bar and a maximum flow rate of up to 260 l/min. - Manual suction system - Extremely lightweight (dry weight of 9.5 kg). Ergonomically shaped handle on top for comfortable carrying - Engine displacement: 49.4 cm <sup>3</sup> - Max. flow rate: 260 l/min - Max. pressure: 6.9 bar	9,5	579817507
without image	<b>Portable pump BH1</b>	without manual suction system	9,5	579817508
	<b>Portable pump BH4-13</b>	UNE-EN 14466:2006. High efficiency, high performance. It is equipped with a 4-stage centrifugal pump and can be combined with 3 different 4-stroke gasoline engines. It achieves a maximum pressure of up to 28.8 bar and a maximum flow rate of 397 l/min. - Engine displacement: 389 cm <sup>3</sup> - Max. flow rate: 380 l/min - Max. pressure: 25.8 bar	56,5	579817509
without image	<b>Portable pump BH4-18</b>	Engine displacement: 570 cm <sup>3</sup> - Max. flow rate: 397 l/min. - Max. pressure: 28,8 bar	61	579817510
	<b>Portable pump BH4-23</b>	Engine displacement: 627 cm <sup>3</sup> - Max. flow rate: 397 l/min. - Max. pressure: 28,8 bar	62	579817511
	<b>Portable pump BP4</b>	The BP4 portable pump is robust and powerful, equipped with a 4-stage centrifugal pump and a 125cc two-stroke engine. This combination allows for working with high flow rates and high pressure over long distances and uphill conditions.  - Max. flow rate: 370 l/min. - Max. pressure: 26,2 bar	22	579817512

## ACCESSORIES EXTINGUISHING MODULE/PORTABLE PUMPS

Product	Name	Description	Length (m)	Part no.
without image	<b>Speed increase vft Pumps</b>			579817513
	<b>4-stage VFT pump (VFT_4SP)</b>			579817514
	<b>vft Pump clamp</b>			579817515
	<b>Suction hose 1.5</b>	for Portable pump BH1 with Storz coupling		579817516
	<b>Plastic suction hose Oversleeve 1-1/2" Storz 52-C // L=3m</b>			579817519
	<b>Plastic suction hose Oversleeve 2" Storz 52-C // L=3m</b>			579817523
	<b>Manual suction pump Storz 52-C</b>			579817528
	<b>vft Pumps Repair kit - 2-, 3- and 4-stage pumps</b>	Contains various tools for the disassembly and assembly of 2-stage, 3-stage, and 4-stage vft pumps.		579817549
	<b>Beamlines SG 540 vft</b>			579817560
without image	<b>Foam system for centrifugal pump skid units</b>			579817575
	<b>Foam system for diaphragm pump skid units</b>			579817576
	<b>Valve manifold D25-D25 (Inlet D25)</b>			579817577
without image	<b>Valve manifold D25-D25 (Inlet C45)</b>			579817578



## ACCESSORIES EXTINGUISHING MODULE/PORTABLE PUMPS

Product	Name	Description	Length (m)	Part no.
	<b>4-layer Hose 25mm - Storz coupling</b>	4-layer fire brigade pants made of fabric, 100% high-strength thread, fully protected and waterproofed by a layer of highly resistant synthetic nitrile rubber, forming a homogeneous three-layer construction without the use of any adhesives.	20	579817586
	<b>4-layer Hose Storz C 42</b>		15 20	579817587 579817588
	<b>4-layer Hose Storz B 75</b>	Features: - Abrasion resistance - Cold resistance - Ozone resistance - Chemical resistance - Heat resistance	15	579817589
	<b>3-layer Hose 25mm - Storz coupling</b>		15 20 25 30	579817609 579817610 579817611 579817612
	<b>3-layer Hose Storz C 42</b>		15 20 25 30	579817613 579817614 579817615 579817616
	<b>3-layer Hose Storz B 75</b>		15 30	579817617 579817618



# FIRE STATION EQUIPMENT



# THE BTL SERIES: FULLY AUTOMATIC AND PROCESS-CONTROLLED BATTERY TESTING AND CHARGING SYSTEM

The devices of the „BTL“ series are fully automatic, processor-controlled battery testing and charging systems with integrated parking space monitoring. Multiple parameters such as on-board voltage, battery charge level, etc. are checked every 50 milliseconds. Depending on the control result, the testing and charging systems react by pulsing the charge, or issuing an optical and acoustic alarm when a fault is detected. The error message can be forwarded to the control center, pagers, or an alarm system through the potential-free alarm output. The batteries are charged gently and supplied with power only as long as necessary.

Pölz's intelligent parking space monitoring devices deliver top performance for the safety of your fleet. However, like anywhere electricity is transported, heat is generated. Therefore, when choosing the installation location for our devices, sufficient ventilation needs to be ensured.

## TECHNICAL DATA

- Power supply 230 V
- Maximum power consumption max. 1800 W
- Minimum battery capacity 32 Ah
- Length of charging cable 4x2,5 mm<sup>2</sup> (max. 50m)
- Protection class IP 21
- Rated frequency 50 Hz
- Rated output voltage 30 V / max. 16 A
- Ambient temperature -20 °C to +50 °C
- Protection class I (according to DIN EN 61558)
- Potential-free alarm output max. 10 A / 230 V
- Optional accessories are available upon request.





#### CONTROL PARAMETERS

- On-board voltage
- Charge level
- Defect
- Connector
- Detection of 12/24 V battery or battery system

## CHARGING DEVICES

Product	Name	Description	Weight (kg)	Part no.
	<b>Battery testing and charging device BTL 2016/4</b>	Fully automatic, processor-controlled battery testing and charging systems with integrated parking space monitoring, including BTL device plug	12	579804785
	<b>Alarm output plug BTL</b>	Suitable for device BTL 2016/4 for intelligent parking space monitoring	0,1	579804786
	<b>Holder for BTL</b>		0,4	579804787
	<b>Automatic Charger Votronic VAC 1224-16 Station with Coiled cable 5m</b>	Charging power 12 and 24 V/16 A. Rated voltage (AC) 230 V. Operating voltage range (AC) 190-265 V	1,4	579804907
	<b>Automatic Charger Votronic VAC 1215 Station with Coiled cable 5m</b>	Charging power 12V/15 A. Rated voltage (AC) 230 V. Operating voltage range (AC) 190-265 V	1,4	579806140
without image	<b>Charging plug Votronic according DIN 14690 incl. Cable gland</b>	2-pin cable connectors with cable gland according to DIN 14690 suitable for automatic cable reels or coiled cables.	0,1	579804908
	<b>Automatic cable reel BEOS SFB 150</b>	4m cable FX 30 with BEOS 3-pin plug to connect with flange coupling of the vehicle installation cable	5	579816866

## CHARGING DEVICES

Product	Name	Description	Weight (kg)	Part no.
	<b>Automatic hose reel BEOS Stand By Flex STD 260</b>	6m PU hose (max. 10 bar) with bend protection spring and pull-out stopper, without quick disconnect coupling	8	579816867
	<b>Quick disconnect coupling</b>	Pressure-locking with signal-colored ripcord NW 5,0 IG 1/4"	0,1	579816868
without image	<b>Vehicle connection hose, extended length 4m</b>	Rotatable G1/4 connection, extreme flexibility, 15bar, -40 °C to 85 °C	0,1	579816869
	<b>Length 6m</b>		1,2	579816870
	<b>Length 8m</b>		1,5	579816871

## MAGIRUS SERVICELINE RED BOX (PART NO. 579816180)

Your range of products for daily turntable ladder maintenance

 SERVICE Line

### Product description

Contains all the necessary products you need for the care and maintenance of your turntable ladder. All products are optimally designed for your requirements.

### Advantages

- All in one box
- Contents can be reordered separately
- Exclusively original Magirus or Magirus certified products







Reorder  
in time!

## MAGIRUS SERVICELINE RED BOX (PART NO. 579816180)

Quantity	Product	Part number	see Page
1	Magirus CONTROL CS	503792276	5
1	LUBE TF	579933573	7
4	Magirus HI-TEC GREASE	579941811	8
1	Magirus LADDERSSET GREASE	503792279	8
1	CL 633 MO	503869611	9
2	Magirus ADHESIVE LUBRICANT	579942745	10
1	GREASE OG	579933572	10
2	N 113	42465072	11
1	Anti-Seize	1094240	11
1	Fin Clean All	579933571	13
4	Hy-Flex gloves size 10		
1	Brush Set & Spatula		
1	Magirus suitcase		



# MOUNTS/STORAGE



## HOSE COMPARTMENTS WOOD

MOUNTS/STORAGE

Product	Name	Description	Length (mm)	Part no.
	<b>Hose compartment B</b> <b>Compartment high</b> <b>Wood</b> <b>H=550 mm</b> <b>Depth=500 mm</b>	Hose compartment B – 1 Section	162	503854970
		Hose compartment B – 2 Sections	314	503855208
		Hose compartment B – 3 Sections	465	503855210
		Hose compartment B – 4 Sections	617	503855215
		Hose compartment B – 5 Sections	768	503855217
		Hose compartment B – 6 Sections	920	503855226
		Hose compartment B – 7 Sections	1071	503855228
		Hose compartment B – 8 Sections	1223	503855232
		Hose compartment B – 9 Sections	1374	503855234
		Hose compartment B – 10 Sections	1526	503855236
	<b>Hose compartment C</b> <b>Compartment high</b> <b>Wood</b> <b>H=500 mm</b> <b>Depth=450 mm</b>	Hose compartment C – 1 Section	122	503856151
		Hose compartment C – 2 Sections	233	503856152
		Hose compartment C – 3 Sections	345	503856153
		Hose compartment C – 4 Sections	456	503856154
		Hose compartment C – 5 Sections	568	503856155
		Hose compartment C – 6 Sections	679	503856156
		Hose compartment C – 7 Sections	791	503856157
		Hose compartment C – 8 Sections	902	503856158
		Hose compartment C – 9 Sections	1014	503856159
		Hose compartment C – 10 Sections	1125	503856160
	<b>Hose compartment D</b> <b>Compartment high</b> <b>Wood</b> <b>H=500 mm</b> <b>Depth=450 mm</b>	Hose compartment D – 1 Section	122	503869670
		Hose compartment D – 2 Sections	233	503869671
		Hose compartment D – 3 Sections	345	503869674
		Hose compartment D – 4 Sections	456	503869675
		Hose compartment D – 5 Sections	568	503869676
		Hose compartment D – 6 Sections	679	503869677
		Hose compartment D – 7 Sections	791	503869678
		Hose compartment D – 8 Sections	902	503869679
		Hose compartment D – 9 Sections	1014	503869680
		Hose compartment D – 10 Sections	1125	503869681





## HOSE COMPARTMENTS WOOD

Product	Name	Description	Length (mm)	Part no.
	<b>Hose compartment B</b> <b>Compartment deep</b> <b>Wood</b> <b>H=500 mm</b> <b>Depth=550 mm</b>	Hose compartment B - 1 Section	162	503855197
		Hose compartment B - 2 Sections	314	503855269
		Hose compartment B - 3 Sections	465	503855270
		Hose compartment B - 4 Sections	617	503855273
		Hose compartment B - 5 Sections	768	503855274
		Hose compartment B - 6 Sections	920	503855277
		Hose compartment B - 7 Sections	1071	503855278
		Hose compartment B - 8 Sections	1223	503855300
		Hose compartment B - 9 Sections	1374	503855301
		Hose compartment B - 10 Sections	1526	503855305
	<b>Hose compartment C</b> <b>Compartment deep</b> <b>Wood</b> <b>H=450 mm</b> <b>Depth=500 mm</b>	Hose compartment C - 1 Section	122	503856171
		Hose compartment C - 2 Sections	233	503856172
		Hose compartment C - 3 Sections	345	503856173
		Hose compartment C - 4 Sections	456	503856174
		Hose compartment C - 5 Sections	568	503856175
		Hose compartment C - 6 Sections	679	503856176
		Hose compartment C - 7 Sections	791	503856177
		Hose compartment C - 8 Sections	902	503856178
		Hose compartment C - 9 Sections	1014	503856179
		Hose compartment C - 10 Sections	1125	503856180
	<b>Hose compartment D</b> <b>Compartment deep</b> <b>Wood</b> <b>H=450 mm</b> <b>Depth=500 mm</b>	Hose compartment D - 1 Section	122	503869692
		Hose compartment D - 2 Sections	233	503869693
		Hose compartment D - 3 Sections	345	503869694
		Hose compartment D - 4 Sections	456	503869695
		Hose compartment D - 5 Sections	568	503869696
		Hose compartment D - 6 Sections	679	503869697
		Hose compartment D - 7 Sections	791	503869698
		Hose compartment D - 8 Sections	902	503869699
		Hose compartment D - 9 Sections	1014	503869700
		Hose compartment D - 10 Sections	1125	503869701

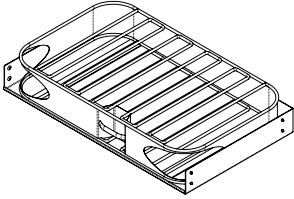

### INDIVIDUAL PARTS HOSE COMPARTMENT

	Side panel B Wood	503854967
	Side panel C Wood	503856149
	Side panel B Aluminium	503855178
	Side panel C Aluminium	503855534
	Spacer B	500278361
	Spacer C	500278362
	Strap - C	500525268
	Strap - B	500525267
	Rivet	41800620
	Aluminium Pipe (Piece goods)	500509369

## STORAGE FOR HOSE CARRYING BASKETS

Product	Name	Description	Length (mm)	Part no.
 	<b>Hose carrying basket Storage Upright vertical</b>	Hose carrying basket B 1 piece	530	500286788
	<b>Hose carrying basket Storage Upright vertical</b>	Hose carrying basket B 2 pieces		503855749
	<b>Hose carrying basket Storage Upright vertical</b>	Hose carrying basket B 3 pieces		503855750
	<b>Hose carrying basket Storage Upright vertical</b>	Hose carrying basket B 4 pieces		503855751
	<b>Hose carrying basket Storage Upright vertical</b>	Hose carrying basket C/D 1 piece		500286787
	<b>Hose carrying basket Storage Upright vertical</b>	Hose carrying basket C/D 2 pieces		503855717
	<b>Hose carrying basket Storage Upright vertical</b>	Hose carrying basket C/D 3 pieces		503855718
	<b>Hose carrying basket Storage Upright vertical</b>	Hose carrying basket C/D 4 pieces		503855721
	<b>Hose carrying basket Storage horizontal</b>	Hose carrying basket B,C horizontal	534	42217267
	<b>Hose carrying basket Storage vertical</b>	Hose carrying basket "B" 3 pieces (B,C,B+C combined)	945	500286171
	<b>Hose carrying basket Storage vertical</b>	Hose carrying basket "B" 4 pieces (B, C, B+C combined)		500286172
	<b>Hose carrying basket Storage vertical</b>	Hose carrying basket "C" 4 pieces (B, C, B+C combined)		503809575
	<b>Hose carrying basket Storage vertical</b>	Hose carrying basket "B" 3 pieces (B, C, B+C combined)		503809579
	<b>Hose carrying basket Storage vertical</b>	Hose carrying basket "B" 2 pieces (B, C, B+C combined)		579933303
	<b>Hose carrying basket Storage vertical</b>	Hose carrying basket "C" 3 pieces (B, C, B+C combined)		579933304

## STRAPS

Product	Name	Description	Length (mm)	Part no.
	<b>Strap blue</b> <b>Strap red</b>	Strap blue 25 mm Strap red 25 mm	Piece goods	500525271 42217400
	<b>Strap with Grommet blue</b>	Strap with Grommet blue 50 mm	660	503152449
	<b>Strap with Grommet red</b>	Strap with Grommet red 50 mm	660	41052938
	<b>Strap with Grommet blue</b>	Strap with Grommet blue 50 mm	500	503152457
	<b>Strap with Grommet red</b>	Strap with Grommet red 50 mm	500	41052942
	<b>Strap with Grommet blue</b>	Strap with Grommet blue 50 mm	270	503152451
	<b>Strap with Grommet red</b>	Strap with Grommet red 50 mm	270	41052939
	<b>Strap with Grommet blue</b>	Strap with Grommet blue 50 mm	100	503152447
	<b>Strap with Grommet red</b>	Strap with Grommet red 50 mm	100	41052937
	<b>Strap with Grommet blue</b>	Strap with Grommet blue 50 mm	80	503152455
	<b>Strap with Grommet red</b>	Strap with Grommet red 50 mm	80	41052941
<b>Strap with Grommet blue</b>	Strap with Grommet blue 50 mm	35	503152453	
<b>Strap with Grommet red</b>	Strap with Grommet red 50 mm	35	41052940	

STRAPS

MOUNTS/STORAGE

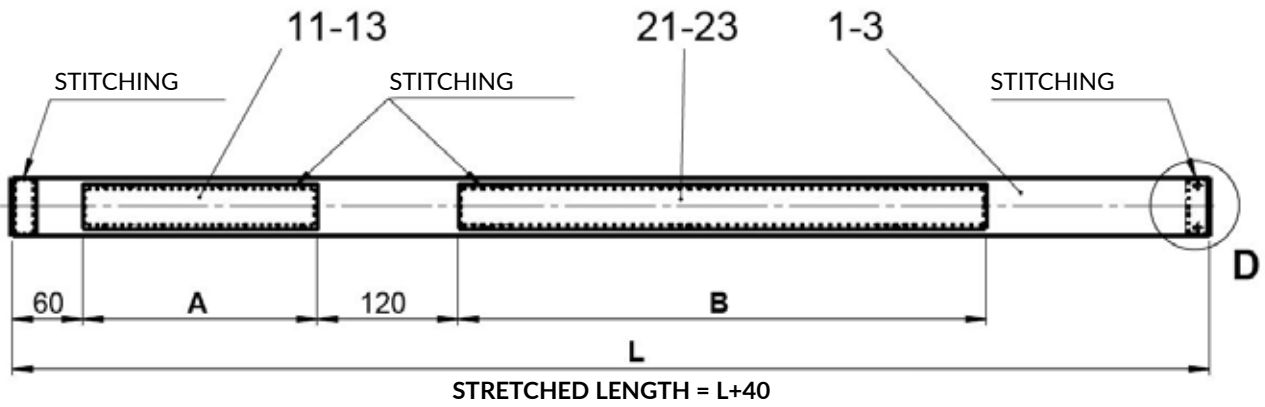







Retaining strap 50 mm			Part no.			Use
A	B	L	Red	Blue	Black	
200	450	1460		503799345		1x4 Replacement cylinders
200	200	650	500290104	500294259		1x2 / 2x2 Replacement cylinders
80	100	440	41085672	500294254		2x Hose carriers
80	100	360	500290223	500294253		4x1 Replacement cylinders
80	150	510	41086544	500294255		1x Foaming agent container
100	150	550	41086542	500294256		Hose protection ramps
80	260	570	41086376	500294257		Ventilation connection
100	150	650	41085533	500294258		Foam pipe
100	150	730	41086543	500294260		2x Foaming agent container
200	200	960	500290105	500294261		1x4 Replacement cylinders
200	200	1080	41086287	500294263		Storage hose carrier Across
200	450	1710	41081308	500294265		2x C-Hose compartment
200	450	1920	41081255	500294266		2x B-Hose compartment
100	160	820	41052098	503151939		Be- U. Ventilation
150	260	740	41052094	503152437		B-Pressure hose 5m
200	450	860	41050646	503152435		1x4 Replacement cylinders
200	170	580	41052935	503152433	41052801	Lf8/6 Allr.
50	100	390	41052934	503152431	42217531	Rw2
200	345	1600	41052933	503152429	41576671	Lf8/6
200	345	870	41052932	503152425	41575124	Rw-Gwg / Bza
200	190	650	41052931	503152423	41575123	Rw-Gwg / Bza
200	450	1190	41052930	503152421	41572806	B-Hose 30m
200	150	675	41052929	503152419	41573091	Lf24-Bza
200	200	880	41052928	503152417	41589063	B-Pressure hose 5m
200	450	1260	41052927	503152415	41585917	B-Hose 35m
200	450	1120	41052926	503152413	41585739	B-Hose compartment
200	450	1020	41052925	503152409	41585738	C-Hose compartment



A = Velcro strips, B = Fleece strips, L = extended length





## STRAPS

Product	Name	Description	Length (mm)	Part no.
	<b>Lashing strap blue Lashing strap blue Lashing strap blue Lashing strap blue Lashing strap blue Lashing strap red Lashing strap red Lashing strap red Lashing strap red</b>	Lashing strap blue 25 mm Lashing strap blue 25 mm Lashing strap blue 25 mm Lashing strap blue 25 mm Lashing strap blue 25 mm Lashing strap blue 25 mm Lashing strap red 25 mm Lashing strap red 25 mm Lashing strap red 25 mm Lashing strap red 25 mm Lashing strap red 25 mm	2400 1600 1200 800 450 450 2400 1600 1200 800 450	503151299 503151301 503151303 503151305 503151307 41052958 41052957 41052956 41052955 41052954
	<b>Lashing strap with Quick lock</b>	Blue 25 mm wide	1000	503200322
	<b>Lashing strap with Quick lock</b>	Red 25 mm wide	1000	500252858
	<b>Fastening strap with Buckle</b>	Strap Blue with Magirus Lettering Width 40mm	840	500525273
	<b>Fastening strap with Buckle</b>	Strap with Buckle Blue und Magirus Lettering Width 40mm	170	500525275
	<b>Disk</b>	Disk to fasten narrow Straps 25x25x3 mm	25	41961106
	<b>Disk</b>	Disk to fasten broad Straps 55x20x3 mm	55	41585891

**ELASTICS**

MOUNTS/STORAGE

Product	Name	Description	Part no.
	<b>Elastic cord</b>	Elastic cord piece goods Clamp ring for securing the elastic cord (2x) Hook without handle Hook with handle  Elastic cords need to be configured individually using the respective part numbers.	41807515 41966823 3505121 3505120
	<b>Clamps</b>	Clamps	500024319

## SMALL PARTS

Product	Name	Description	Length (mm)	Part no.
	<b>Aluminium angle profile</b>	To secure boxes and storage in the equipment room Aluminium angle profile 40x40x6	Piece goods	41051225
	<b>PVC grey</b> <b>PVC blue</b>	This PVC is inserted into the aluminium angle profile to avoid direct contact between aluminium boxes and the aluminium surface of the angle profile.	Piece goods Piece goods	41051227 503164187
	<b>PVC-Angle profile</b>	To secure boxes and storage in the equipment room PVC Profile 40x40x6		500289082
	<b>Handle yellow</b>	Handle yellow 125x48,5		503164351
	<b>Stop red</b> <b>Stop blue</b> <b>Stop blue</b>	Stop red 36x20x15 Stop blue 36x20x15 Stop blue 33x20x15		500289081 500527770 500527771
	<b>Stop blue</b>	Stop blue 33x20x15 Nose for Aluminium Angle profile		503164241
	<b>Roller stand</b> <b>Roller</b>	For compartmentalized removal of long boxes (requires both items).		41051230 41051228
	<b>Locking pin</b>	For stop at the end of the aluminium angle profiles.		41051385
	<b>Box lock</b>	Use in equipment room to avoid boxes coming loose.		503154067

## SMALL PARTS





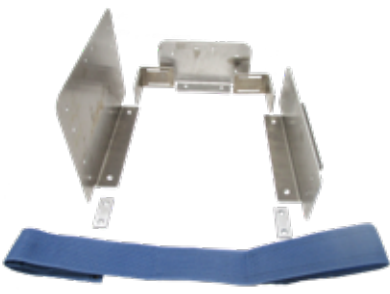

Product	Name	Description	Length (mm)	Part no.
	<b>Lock</b>	Use in equipment room Ø 61mm, 22mm high		41682553
	<b>Clamping spring</b>	Clamping spring up to Ø 15 mm Clamping spring up to Ø 25 mm Clamping spring up to Ø 30 mm Clamping spring up to Ø 40 mm Clamping spring up to Ø 60 mm Clamping spring up to Ø 70 mm		41800625 41800218 3464505 1236763 1236761 2761694
	<b>Knurled screw</b>	Knurled screw M6x15 It is used for the battery box in the crew compartment under the seat box S2 or for various covers of the central electrical system.		500277969
	<b>Hinge</b>	Aluminium hinge 60x60mm (roof box)		500576013
	<b>Hinge</b>	Aluminium friction hinge 50 x 55 mm used in the equipment room.		500254526
	<b>Latch blue</b> <b>Latch red</b>	Latch blue Latch red		500525893 500263115

## SMALL PARTS



Product	Name	Description	Length (mm)	Part no.	
	<b>Shelf bracket</b>	Height 100mm Depth 40mm	900	503836314	
			800	503836313	
			700	503836312	
			600	503836311	
			550	503836310	
			500	503836309	
			450	503836308	
			400	503836307	
			350	503836306	
			300	503836305	
			250	503836304	
			200	503836303	
			150	503836302	
			100	503836300	
			Height 200mm Depth 40mm	900	503836334
			Height 200mm Depth 40mm	800	503836333
			Height 200mm Depth 40mm	700	503836332
			Height 200mm Depth 40mm	600	503836331
			Height 200mm Depth 40mm	550	503836330
			Height 200mm Depth 40mm	500	503836329
			Height 200mm Depth 40mm	450	503836328
			Height 200mm Depth 40mm	400	503836327
		Height 200mm Depth 40mm	350	503836326	
	Height 200mm Depth 40mm	300	503836325		
	Height 200mm Depth 40mm	250	503836324		
	Height 200mm Depth 40mm	200	503836323		
	Height 200mm Depth 40mm	150	503836322		
	Height 200mm Depth 40mm	100	503836320		
	<b>Connecting bracket</b>	Connecting bracket for shelf bracket 50mm adjustable	75	503836360	

## MOUNTING BRACKETS

MOUNTS/STORAGE

Product	Name	Description	Part no.
	<b>Mounting bracket rectangular</b>	Mounting bracket with Aluminium Buffer Inner dimension with buffer: Ø 50mm Inner dimension without buffer: approximately Ø 80mm	41680963
	<b>Aluminium buffer for mounting bracket</b>	Used for attaching the roof winch.	41938769
	<b>Mounting bracket rectangular</b>	Mounting bracket without rubber buffer to attach smaller roof winch 80 x 80 mm Rubber buffers need to be ordered separately, see next item.	500509538
	<b>Rubber buffer for Mounting bracket</b>	Height 40 mm Height 30 mm Height 24 mm Height 22,5 mm Height 18 mm Height 15 mm Height 10 mm	1230117 1240263 1236504 1236506 500509360 1230793 1236502
	<b>Tension bearing for round parts</b>	Tension bearing maximum Ø 35 mm Tension bearing maximum Ø 40 mm	41680873 500247811
	<b>Rubber buffer for Tension bearing</b>	Ø 14 x 6 mm Ø 20 x 6 mm For reducing the clamping diameter.	3442175 3420979
	<b>Mounting bracket</b>	with long rubber with short rubber for example, for vertical storage of axes	41586171 41586170

## LATCHES

Product	Name	Description	Part no.
	<b>Lock</b>	Right lock ball head red Left lock ball head red	41969793 41581965
		Disk dimension: 50x24mm Application: E.g., light bridge storage, spotlight container storage.	
	<b>Lock</b>	Right lock ball head black Left lock ball head black	503869622 503869618
		Disk dimension: 50x24mm Application: E.g., light bridge storage, spotlight container storage.	
	<b>Latch bolt</b>	Latch bolt with tapered pin complete	41584406
		Latch bolt complete	500501509
		Latch bolt base	41680639
		Handle	1236643
		Spring	1236641
		Tension pin	1115405
		Cylindrical replacement bolt	41800168

## ADDITIONAL STORAGE

MOUNTS/STORAGE

Product	Name	Description	Part no.
	<b>Bolt</b>	Standard bolt for various storage options in the basket, such as spotlights or aluminium containers, chainsaws, and other aluminium containers.	500561771
	<b>Box RC300</b>	Storage box, outside of basket, on left side, for e.g., nozzle pipes and hoses	503832570
	<b>Box RC300</b>	Storage box, outside of basket, on right side, for e.g., nozzle pipes and hoses	503832652
	<b>Box RC400</b>	Storage box, outside of basket, on left and right side, for e.g., nozzle pipes and hoses	503189366
	<b>Storage Ramps</b>	Storage Ramps under rotating gearbox, left side	503844169
	<b>Storage Ramps</b>	Storage Ramps under rotating gearbox, right side	503844168
	<b>Storage Monitor</b>	Storage at rotating gearbox, for e.g., a monitor	500257154
	<b>Storage at rotating gearbox</b>	Multifunctional storage at rotating gearbox, above-floor installation, for e.g., a monitor.	503844376







## ADDITIONAL STORAGE

Product	Name	Description	Part no.
	<b>Storage at rotating gearbox</b>	Multifunctional storage at rotating gearbox, flush-floor installation, for e.g., a monitor.	503844377
	<b>Retaining disc</b>	Plastic retaining disc Storz A Plastic retaining disc Storz B-C	503152224 3477258
	<b>Retaining disc</b>	Retaining disc Steel sheet galvanized A	579930150
	<b>Retaining disc</b>	Retaining disc Steel sheet galvanized B	500262575
	<b>Retaining disc</b>	Retaining disc Steel sheet galvanized C	500262576
	<b>Storage Coupling wrench</b>	1 Coupling wrench ABC DIN 14822 Length 470mm Width 23mm	41961457
	<b>Storage Coupling wrench</b>	2 Coupling wrench ABC DIN 14822 Length 470mm Width 46mm	41961458
	<b>Storage Coupling wrench</b>	3 Coupling wrench ABC DIN 14822 Length 470mm Width 69mm	41961459
	<b>Storage Coupling wrench</b>	4 Coupling wrench ABC DIN 14822 Length 470mm Width 92mm	41961460
	<b>Plastic box</b>	Plastic box (for chainsaw accessories) 130x92mm	2760741
	<b>Bag</b>	For Storz C- coupling or foam gun Ø 90mm	41967179
	<b>Protective cover</b>	Protective cover for flashing warning lights	4461731
	<b>Hanger</b>	Plastic hanger	98474370
	<b>Hanger</b>	Aluminium hanger	503161686

## ADDITIONAL STORAGE

Product	Name	Description	Part no.
	<b>Reflector</b>	Reflector, self-adhesive 91x61mm	42215541
	<b>Handle</b>	1) Handle 280x30x55mm (length x width x height) e.g., handle for equipment compartment 2) Plug for long handle (41681079) 3) Handle 170x28x52mm (length x width x height) e.g., handle for equipment compartment, drawer GR 4) Handle 190x51x35mm (length x width x height) e.g., handle for roof box	41681079 42225612 503867596 86003590
	<b>Distributor storage</b>	CK/CV/BK/BV	579933566
	<b>Additionally required for retrofit:</b> 1 x rubber band 2 x retaining grommet	Length 300 mm	2761385 500024319
	<b>Chock Storage</b>	Chock Storage/Bearing plate Chock Storage/Holder Chock Storage/Bearing plate	41681171 41681167 41681162
	<b>Frame made of Aluminium</b>	for 2 manhole hooks LxW 175x61 mm 37 mm Internal dimension	41961138
	<b>Spade Storage</b>	LxW 186x40mm	2760986
	<b>Snow scoop Storage</b>		42218159
	<b>Clamping spring for Respiratory protection</b>		41575495

## ADDITIONAL STORAGE

Product	Name	Description	Part no.
	<b>Clamp jaw for Respiratory protection</b>		503200942
	<b>Nozzle Storage</b>	LxW 170x45mm	41972939
	<b>Nozzle Storage C</b>	for Nozzles with Connection Storz C for Ø 90 mm	41053501
	<b>Nozzle Storage B</b>	for Nozzles with Connection Storz B for Ø 110 mm	41053502
	<b>Protective cover for Hooligan tool</b>		500277366
	<b>Nozzle storage</b>	Storage for 1x B-nozzle Storage for 1x C-nozzle Storage for 2x C-nozzle	503836643 500265550 503836641

## ADDITIONAL STORAGE

MOUNTS/STORAGE

Product	Name	Description	WxH (mm)	Part no.
	<b>Spare PA bottle storage Ø 115mm</b>	Single storage	130x130	503799108
		Double storage stacked	130x260	500278025
		3 storage compartments stacked	130x390	500278026
		4 storage compartments stacked	130x520	500278027
		4 storage compartments square	260x260	500278028
	<b>Spare PA bottle storage Ø 140mm</b>	Single storage	155x155	500278030
		Double storage stacked	155x310	500278031
		3 storage compartments stacked	155x465	500278032
		4 storage compartments stacked	155x620	500278033
	<b>Spare PA bottle storage Ø 155mm</b>	4 storage compartments square	310x310	500278034
		Single storage	170x170	500278036
	<b>Spare PA bottle storage Ø 165mm</b>	Double storage stacked	170x340	500278037
		3 storage compartments stacked	170x510	500278038
		4 storage compartments stacked	170x680	500278039
		4 storage compartments square	340x340	503799651
		Single storage	180x180	503151494
	Double storage stacked	180x360	503799663	
	3 storage compartments stacked	180x540	503799665	
	4 storage compartments stacked	180x720	503799666	
	4 storage compartments square	360x360	503799664	
	<b>Single-use gloves Storage</b>	LxWxH 251x140x90mm		503832750
	<b>Bag for manhole hook etc.</b>			41964014

NEXT GENERAT



# MAXIMUM RESCUE LOAD – MINIMUM EFFORT

The Magirus **RESCUESUPPORT RS300** basket stretcher support

Whether for challenging rescues of persons or to support conventional operations at heights and depths - the RescueSupport RS300 from Magirus offers emergency services another simple and effective solution for rescuing people weighing up to 300 kg quickly and safely. In conjunction with a turntable ladder it ensures to transport them gently. Thanks to a set-up time of only 20 seconds, the basket stretcher support is quickly ready to use. Experience the firefighting technology of the future that is already available today!

More  
about the  
RS300



## TELESCOPIC SLIDE ALUMINIUM

MOUNTS/STORAGE

Product	Name	Description	Width (mm)	Part no.
	<b>Telescopic slide 450</b>	Sheet metal load-bearing capacity 130kg Slide load-bearing capacity 190kg Total length 490mm Extended 420 mm Height 80,5mm	240	579931045
			365	579931046
			415	579931047
			465	579931048
			515	579931049
			615	579931050
			665	579931051
			715	579931052
			815	579931053
			865	579931054
			915	579931055
1015	579931056			
1165	579931057			
	<b>Telescopic slide 540</b>	Sheet metal load-bearing capacity 130kg Slide load-bearing capacity 190kg Total length 580mm Extended 510 mm Height 80,5mm	240	579931060
			365	579931061
			415	579931062
			465	579931063
			515	579931064
			615	579931065
			665	579931066
			715	579931067
			815	579931068
			865	579931069
			915	579931070
1015	579931071			
1165	579931072			
	<b>Telescopic slide 630</b>	Sheet metal load-bearing capacity 130kg Slide load-bearing capacity 190kg Total length 670mm Extended 615 mm Height 80,5mm	240	579931074
			365	579931075
			415	579931076
			465	579931077
			515	579931078
			615	579931079
			665	579931080
			715	579931081
			815	579931082
			865	579931083
			915	579931084
1015	579931085			
1165	579931086			
	<b>Telescopic slide 750</b>	Sheet metal load-bearing capacity 130kg Slide load-bearing capacity 190kg Total length 790mm Extended 720 mm Height 80,5mm	240	579931089
			365	579931090
			415	579931091
			465	579931092
			515	579931093
			615	579931094
			665	579931095
			715	579931096
			815	579931097
			865	579931098
			915	579931099
1015	579931100			
1165	579931101			

## TELESCOPIC SLIDE ALUMINIUM

Product	Name	Description	Width (mm)	Part no.
	<b>Telescopic slide 950</b>	Sheet metal load-bearing capacity 130kg Slide load-bearing capacity 190kg Total length 990mm Extended 920 mm Height 80,5mm	240	579931104
			365	579931105
			415	579931106
			465	579931107
			515	579931108
			615	579931109
			665	579931110
			715	579931111
			815	579931112
			865	579931113
			915	579931114
1015	579931115			
1165	579931116			
	<b>Telescopic slide 1250</b>	Sheet metal load-bearing capacity 130kg Slide load-bearing capacity 190kg Total length 1290mm Extended 1220 mm Height 80,5mm	240	579931119
			365	579931120
			415	579931121
			465	579931122
			515	579931123
			615	579931124
			665	579931125
			715	579931126
			815	579931127
			865	579931128
			915	579931129
1015	579931130			
1165	579931131			
	<b>Telescopic slide 1100</b>	Sheet metal load-bearing capacity 250kg Slide load-bearing capacity 300kg Total length 1140mm Extended 920 mm Height 80,5mm	415	579931134
	<b>Telescopic slide 1250</b>	Sheet metal load-bearing capacity 250kg Slide load-bearing capacity 300kg Total length 1290mm Extended 1220 mm Height 80,5mm	665	579931140
			865	579931141
			515	579931142
	<b>Telescopic slide</b>	Rotatable for Generator Total length 535mm Extended 500mm	715	500286522

Further configurations upon request

## PROFILE TECHNOLOGY

MOUNTS/STORAGE

Product	Name	Description	Part no.	
	<b>Strip profile</b>	Strip profile 1W 30x30	500509026	
	<b>Strip profile</b>	Strip profile 2W 50x30	500509021	
	<b>Strip profile</b>	Strip profile 2W 55x30	500509024	
	<b>Strip profile</b>	Strip profile 3W 70x30	500509025	
	<b>Strip profile</b>	Strip profile 3W 55x50	500509027	
	<b>Strip profile</b>	Strip profile 4W 70x55	500509022	
	<b>Strip profile</b>	Strip profile 2W 50x50	500283213	
	<b>Strip profile</b>	Strip profile 2W 62,5x52,5	500509028	
	<b>Strip profile</b>	Strip profile 2W 55,2x52,5	500509023	
	<b>Accessories:</b>			
	<b>Aluminium cover strip</b>	Aluminium cover strip	41830444	
	<b>Rubber cover strip</b>	Rubber cover strip	500261221	
	<b>Strip</b>	Strip	41830234	
	<b>Clamping piece M8</b>	Clamping piece M8	41582831	
<b>Clamping piece M6</b>	Clamping piece M6	41585534		
<b>Clamping piece M5</b>	Clamping piece M5	41587035		
<b>Countersunk screw M8 with lock</b>	M8x19 Countersunk screw	41823771		
<b>Cover strip</b>	Cover strip for backlighting	503174141		
	<b>Corner fitting</b>	Corner fitting-L 90° 50 x 50 mm	41585295	
		Corner fitting-L 90° 100 x 100 mm	41585296	
		Corner fitting-L 135° 115 x 115 mm	41585782	
		Corner fitting-L 120° 115 x 115 mm	41585783	
		Corner fitting-L 135° 65 x 65 mm	41585785	
		Corner fitting-L 150° 65 x 65 mm	41585787	
		Corner fitting-L 45° 65 x 65 mm	41586520	
		Corner fitting-L 90° 50 x 38 mm	41087332	
		Corner fitting-U B = 40 mm	41588639	
		Corner fitting-U B = 45 mm	41588640	
		Corner fitting-U B = 50 mm	41588641	
		Corner fitting-U B = 55 mm	41588642	
		Corner fitting-U B = 60 mm	41588643	
		Corner fitting-U B = 65 mm	41588644	
		Corner fitting-U B = 70 mm	41588645	
		Corner fitting-U B = 75 mm	41588646	
		Corner fitting-U B = 80 mm	41588647	
		Corner fitting-U B = 85 mm	41588648	
	Corner fitting-U B = 90 mm	41588649		



# MERCHANDISE



# A LADDER FOR THE HISTORY BOOKS

The „Ulmer Leiter“ was a revolution for both Magirus and the entire firefighting industry. In 1872, this completely redesigned ladder was introduced in Germany, and it was destined to achieve international success.



The special feature of this ladder was the mounting of its end on an axis, which made manoeuvring in narrow streets noticeably easier. This was particularly useful during operations in big cities. Furthermore, the ladder provided firefighters with a time advantage, as it could be set up within a minute and remained movable even when fully extended.

With these and other innovations, Magirus won a gold medal at the Vienna World Exhibition one year later. This significant success ultimately paved the way for the company to build its first factory.

## „ULMER LEITER“ WITH FIGURE C.D. MAGIRUS - 1872

- RIETZE historical collector's model
- Scale 1:43
- In special packaging „Magirus“

Part no. 579803459









## MODELS

Product	Name	Description	Colour	Part no.
	<b>„Ulmer Leiter“ with figure C.D. Magirus - 1872</b>	RIETZE historical collector's model: „Ulmer Leiter“ by Conrad Dietrich Magirus. Limited edition. Scale: 1:43.	brown / blue	579803459
	<b>Magirus „SLG 3000“ (1941)</b>	LUCKY TOYS metal model. Scale: 1:43.		579803461
	<b>Magirus-Deutz „TLF 16“ (1964)</b>	LUCKY TOYS metal model. Scale: 1:43.		579803462
	<b>Magirus „LF 8“ (1965)</b>	LUCKY TOYS metal model: Historical model of the firefighting vehicle „LF 8“ (1965). Scale: 1:43.	red	579803465
	<b>Magirus-Deutz „TLF 16“ THW (1964)</b>	LUCKY TOYS metal model: Tank firefighting vehicle „TLF 16“ for the Federal Agency for Technical Relief (1964). Scale: 1:43.	blue	579803463
	<b>Magirus „M32L-AS“ (Euro 6)</b>	RIETZE plastic model. Scale 1:87.		579807150
	<b>Magirus „M32L“ (Euro 3)</b>	BBURAGO metal model: Turntable ladder „M32L“ on Euro 3 chassis. Scale 1:50.	red	579803470



## MODELS

Product	Name	Description	Colour	Part no.
	<b>Magirus „M32L“</b>	RIETZE plastic model: Turntable ladder „M32L“. Collector's model in special packaging „Magirus“. Scale 1:87.	red	579803476
	<b>Magirus „M32L-AS“</b>	RIETZE plastic model. Articulated turntable ladder „M32L-AS“. Collector's model in special packaging „Magirus“. Scale 1:87.	red	579803477
	<b>Magirus „HLF 20 ALUFIRE 3“</b>	RIETZE plastic model. Collector's model in special packaging „Magirus“. Scale 1:87.	red	579803481
	<b>Magirus „HLF 20 Team Cab“</b>	RIETZE plastic model. Collector's model in special packaging „Magirus“. Scale 1:87.		579807149
	<b>Magirus „Rescue vehicle“</b>	RIETZE plastic model. Collector's model in special packaging „Magirus“. Scale 1:87.	red	579803482
	<b>Magirus „MK“</b>	RIETZE plastic model. MK series with „München“ labelling. Scale 1:87.	red	579803483
	<b>Magirus „Rescue vehicle“</b>	BBURAGO metal model Rescue vehicle. Scale 1:50.	red	579804888

## CHILDREN

Product	Name	Description	Colour	Part no.
	<b>Teddy bear „Magirus“</b>	Soft plush toy with "Magirus" printed on the neck scarf. Sitting approximately 20 cm tall.	beige / red	579803485
	<b>Children's toy „Power Worker fire brigade“</b>	BIG, made of durable plastic. Fire ladder can be extended, redated, and swivelled up to 41 cm.	red	579803486
	<b>Magirus „Turntable ladder“</b>	SIKU metal model. Scale: 1:50.	red	579803489
	<b>Magirus „Tank pumper“</b>	SIKU metal model. Scale: 1:50.	red	579803490
	<b>Children Baseball Cap „Magirus“</b>	Stitched „Magirus“ Logo.	white	579803491
	<b>Children's ride-on car „Magirus fire brigade“</b>	FERBEDO with trailer hitch, whisper tires, blue light, and siren. For children aged 1 - approximately 4 years. Size: 59x30x42 cm.	red	579815610
	<b>Sled Carver Snoop „Magirus“</b>	FERBEDO Children's sled made of high-quality plastic, with pulling rope and blue light. For children aged 4 and above. Size: 105x47x18 cm.	red	579807467

**CHILDREN**









Product	Name	Description	Colour	Part no.
	<b>Bedding set „Firefighter“</b>	BASSETTI: Duvet 135x200 cm and pillow 50x80 cm.	white / black	579803497
	<b>Bedding set „Firefighter“</b>	BASSETTI: Duvet 135x200 cm and pillow 80x80 cm.	white / black	579803498

MERCHANDISE

## ACCESSORIES

Product	Name	Description	Colour	Part no.
	<b>Magirus beer mug</b>	The classic 0.5L stoneware mug with "Magirus" printing.		579816942
	<b>Design bottle opener</b>	Metal, with „Magirus“ printing.	red / silver	579804417
	<b>Salt and pepper shaker „Magirus“</b>	WMF, stainless steel, discreet engraving on the back with "Magirus" logo.	silver	579803501
	<b>Grill utensils „Magirus“</b>	Tongs, fork, and turner made of stainless steel, packaged in a high-quality aluminium case, with laser engraving "Magirus".	silver	579803507
	<b>Water bottle „Magirus“</b>	0,5l water bottle with „Magirus“ printing 0,75l water bottle with „Magirus“ printing	silver black	579816968 579818122
	<b>Thermal cup „Magirus“</b>	Silver, with engraving „Magirus“, 2 cups. Volume: 0,75 l.	silver	579803524

## ACCESSORIES

Product	Name	Description	Colour	Part no.
	<b>Coffee mug</b>	Ceramic coffee mug with „Magirus“ logo. Capacity: 0,3 l.	black	579803525
			red	579803526
	<b>Cooler „Magirus“</b>	Insulated cooler bag with spacious main compartment and roll-top closure. Suitable for up to 12 cans.	brown	579818116
	<b>Lunch box „Dinner-Box“ Range</b>	Breakfast box, food-safe, versatile. Available with „Magirus Range“ or „TLF 3000-W“ design. Size: 185x128x65 mm.	white	579816598
	<b>Lunch box „Dinner-Box“ TLF 3000-W</b>		white	579816599
	<b>Lighter „Magirus“</b>	BIC, with „Magirus“ printing.	black	579803521
	<b>Pocket knife „Magirus“</b>	Stainless steel/wood, with foldable scissors, knife, can opener, bottle opener, corkscrew, awl, file, hole punch, fish scaler, and Phillips screwdriver.	silver / brown	579803522
	<b>USB stick „Magirus“</b>	Stainless steel with engraving of „Magirus“.	silver	579803504



## ACCESSORIES

Product	Name	Description	Colour	Part no.
	<b>Wooden wedge</b>	Wedge made of beech wood with printing „Magirus“	brown	579804351
	<b>Multifunctional light „Magirus“</b>	Flashlight with magnet. Equipped with 7 LEDs as front lights, 18 LEDs as work lights, and 6 LEDs as red blinking light. Includes batteries (3 x AAA)	silver	579803505
	<b>Safety flashlight „Magirus“</b>	Sturdy flashlight with window emergency hammer and seatbelt cutter, laser engraving „Magirus“. It has 6 LEDs and a xenon lamp. Includes belt pouch and batteries.	silver	579803506
	<b>„M“ pin, cast</b>	Metal cast pin, painted in red, with 1 pin on the back and a butterfly clasp.	red	579816370
	<b>Keychain „Carabiner“</b>	Aluminium carabiner with fabric strap and keyring, featuring the imprint „Magirus“.	black	579803511
	<b>Keychain „Tools“</b>	Matte silver metal, packaged in a gift box. It includes a folding nail file, pocket knife, bottle opener, and mini scissors.	silver	579803512
	<b>Lanyard „Magirus“ long</b>	Neck strap, 20 mm wide, with a carabiner hook and detachable key section. Imprint „Magirus“.	black	579803515
	<b>Lanyard „Magirus“ short</b>	Neck strap, 20 mm wide, with a carabiner hook and imprint „Magirus“.	black	579803516
	<b>Automatic umbrella „Magirus“</b>	Aluminium umbrella with foam grip and „Magirus“ logo.	white	579803517
	<b>Ink pen „Magirus“</b>	Ceramic-tip pen with imprint „Magirus“. Blue ink.	black	579807334
	<b>Ballpoint pen „Magirus“</b>	With imprint „Magirus“. Blue ink.	white	579803518







## ACCESSORIES

Product	Name	Description	Colour	Part no.
	<b>Notepad „Magirus“</b>	DIN A4, 50 sheets.	white	579803519
	<b>Leisure backpack Magirus</b>	Features embroidered „Magirus“ logo, original 3M safety reflective stripes, convenient strap holder, and multiple organizational compartments. Volume: 35 litres.	black/red	579816129
	<b>Puzzle „Magirus Mercury 125“</b>	RAVENSBURGER, 500 pieces.	colourful	579803510
	<b>Document bag „Magirus“</b>	A4-sized document folder with many storage compartments and attachable clipboard.		579808700
	<b>Towel „Magirus“</b>	Material: Terry cloth, size: 140x67 cm	grey	579816971
	<b>Shower towel „Magirus“</b>	Material: Terry cloth, size: 100x50 cm	grey	579816972
	<b>Ball pen „Magirus“ historic</b>	Metal, with historical „Magirus“ logo.		579803520
	<b>Magirus key holder Turntable low profile chassis</b>			5798909653

## BOOKS

Product	Name	Description	Colour	Part no.
	<b>Book „Magirus“ 2014 - DE</b>	People – Company – Products in German.	white / colourful	579803528
	<b>Book „Magirus“ 2014 - EN</b>	People – Company – Products in English.		579803529
	<b>Book „Magirus“ 2014 - FR</b>	People – Company – Products in French.		579803530
	<b>Book „Magirus“ 2014 - IT</b>	People – Company – Products in Italian.		579803531
	<b>Book „Fire emotion“</b>	History, Vehicles, Technology and Emotions. Bilingual edition, German and English.	white / colourful	579803533

## CLOTHING

Product	Name	Description	Colour	Part no.
	<b>Belt, male „Magirus“</b>	Black, Leather Belt with Metal Buckle and Laser Engraving „Magirus“, approximately 125-130 cm long, 35 mm wide.	black	579803523
	<b>MAGIRUS Socks Male</b>		black	579816965
	<b>MAGIRUS Socks Female</b>		black	579816967
	<b>Baseball Cap „Fire Fighter Academy“</b>	Embroidered with „Magirus Fire Fighter Academy“ Logo.	black	579803581
	<b>Baseball Cap „Magirus“</b>	Embroidered with „Magirus“-Logo.	black	579803582
	<b>Beanie „Magirus“</b>	Embroidered with „Magirus“-Logo.	black	579803583
	<b>Bandana multifunctional scarf „Magirus“</b>		black	579816969
	<b>Bandana multifunctional scarf „Magirus“</b>		grey	579816970

# OUR DOCUMENT CASE MAGIRUS: PRACTICAL, HANDY, EASY TO CARE FOR & VERSATILE



The flexible Magirus document case (DIN A4 format) features many different document compartments. Two pen holders ensure that writing materials are always available when needed. The clipboard inside the bag is secured with a Velcro strap and can be used for holding notepads, for example. A carabiner with keyring, which can be attached to one of the loops, and an integrated tablet holder provide even more convenience. Transparent compartments on the outside of the bag allow for personalized identification (e.g., by inserting a business card).

## FEATURES

- The washable exterior material is very easy to care for and durable.
- Additional loops with metal rings are attached to the front and back, allowing the bag to be easily carried with an optional shoulder strap.

## Part Sales Terms and Conditions - Vehicle Parts, Replacement Engines/Units, and Accessories (As of 05/

### I. Exclusive Applicability

The seller provides its services exclusively based on these sales terms and conditions, unless otherwise agreed upon in writing between the contracting parties. The buyer acknowledges the seller's sales conditions. Deviating terms and conditions of the buyer shall only apply if and to the extent that the seller expressly acknowledges them in writing. This also applies in cases where the seller has not expressly objected to them or provides its services, either in whole or in part, without explicit objection.

### II. Payment

1. The purchase price and prices for additional services are due for payment upon delivery of the purchased item and handover or transmission of the invoice. The seller is entitled to transmit invoices, including interim and final invoices, electronically.
2. The buyer may only set off claims against the seller if the buyer's counterclaim is undisputed or has been confirmed by a legally binding judgment. This does not apply to the buyer's counterclaims arising from the same sales contract. The buyer may only assert a right of retention to the extent that it is based on claims arising from the same contractual relationship.
3. If the buyer fails to pay the due purchase price and prices for additional services or fails to do so in accordance with the contract, the seller may withdraw from the contract and/or claim damages instead of performance in the event of the buyer's culpable breach of duty, provided that the seller has unsuccessfully set a reasonable deadline for performance by the buyer, unless setting a deadline is dispensable according to legal provisions.

### III. Delivery and Delayed Delivery

1. Delivery dates and deadlines, whether binding or non-binding, must be specified in writing. Delivery deadlines commence upon conclusion of the contract.
2. If an agreed non-binding delivery deadline or non-binding delivery period is exceeded, the buyer may request the seller to deliver within ten days. The seller is deemed to be in delay upon receipt of the request. If the buyer is entitled to claim compensation for delay, such compensation is limited to a maximum of 5% of the agreed purchase price in cases of slight negligence on the part of the seller.

3. If the buyer wishes to withdraw from the contract and/or claim damages instead of performance in addition to the rights mentioned in Section 2 of this clause, the buyer must set a reasonable deadline for delivery to the seller after the expiry of the ten-day period specified in Section 2 of this clause. In cases of slight negligence, the buyer's claim for damages instead of performance is limited to a maximum of 25% of the agreed purchase price. If the buyer is a legal entity under public law, a special public asset, or a business operator acting in the exercise of their commercial or independent professional activity at the time of contract conclusion, claims for damages in cases of slight negligence are excluded.

If, while the seller is in delay, delivery becomes impossible due to accidental circumstances, the seller is liable according to the above-mentioned limitations of liability. The seller is not liable if the damage would have occurred even with timely delivery.

4. If a binding delivery date or binding delivery period is exceeded, the seller is already in delay upon exceeding the delivery date or delivery period. The buyer's rights are then determined in accordance with Section 2, sentence 3, and Section 3 of this clause.
5. The limitations of liability and exclusions of liability in this section do not apply to damages resulting from grossly negligent or intentional breach of obligations by the seller, its legal representative, or its vicarious agents, as well as in cases of injury to life, body, or health.
6. Force majeure or operational disruptions occurring at the seller's or its suppliers' premises, which temporarily prevent the seller from delivering the purchased item at the agreed-upon date or within the agreed-upon period, without the seller's own fault, will extend the deadlines and periods mentioned in clauses 1 to 4 of this section by the duration of the performance disruptions caused by these circumstances. If such disruptions result in a delay of more than four months, the buyer may withdraw from the contract. Other rights of withdrawal remain unaffected.

### IV. Delivery of Replacement Engines and Units

In exchange for a used engine or unit, a reconditioned engine or unit of the same model with the same design features will be delivered. Minor deviations in execution are reserved. The used engines/units to be exchanged must be delivered by the buyer to the seller within 14 days from the delivery date of the replacement engine/unit, completely assembled, cleaned, and without oil, in an unbroken, welded, and crack-free condition, without damage to the crankshaft. If the delivered used engines/units do not meet these condition requirements, a deduction will be made from the core deposit or an additional charge will be applied. Complaints regarding the condition of the used parts must be made within eight weeks from the delivery date. The exchanged used engine or unit becomes the property of the seller at the time of delivery. The buyer expressly declares that the delivered used part is in their unencumbered ownership or that they are authorized or empowered to transfer ownership and that no third-party rights.

### V. Acceptance

1. The buyer is obligated to accept the purchased item within eight days from the receipt of the notification of availability. In case of non-acceptance, the seller may exercise their legal rights.
2. If the seller claims damages based on a legal entitlement, such damages shall amount to 10% of the purchase price. The damages may be higher or lower if the seller proves a higher damage or the buyer proves that no or lesser damage has occurred.

## VI. Retention of Title

1. The purchased item remains the property of the seller until full payment has been made for the seller's claims arising from the purchase contract.  
If the buyer is a legal entity under public law, a public-law special fund, or a business operator acting in the exercise of their commercial or independent professional activity at the time of contract conclusion, the retention of title also applies to claims that the seller has against the buyer from the ongoing business relationship until the settlement of claims related to the purchase. Upon the buyer's request, the seller is obliged to waive the retention of title if the buyer has irrevocably fulfilled all claims related to the purchased item and adequate security exists for the remaining claims from the ongoing business relationship.
2. The buyer is entitled to process and resell the purchased item in the ordinary course of business as long as they are not in default. Pledges or assignments for security purposes are not permitted. The buyer hereby assigns, as security, any claims arising from the resale or any other legal grounds concerning the purchased item to the seller up to the invoice amount as stated in Section I, „Payment,“ Clause 1. The seller authorizes the buyer, revocably, to collect the assigned claims in their own name for the seller's account. This collection authorization can only be revoked if the buyer fails to fulfill their payment obligations properly.

## VII. Liability for Material Defects

1. Claims of the buyer for material defects expire within two years for new vehicle parts and within one year for used parts, starting from the time of delivery of the purchased item. If the buyer is a legal entity under public law, a public-law special fund, or a business operator acting in the exercise of their commercial or independent professional activity at the time of contract conclusion, claims for material defects expire within one year for new vehicle parts, starting from the time of delivery of the purchased item; for used vehicle parts, the liability for material defects is excluded.
2. The shortening of the limitation period and the exclusion of liability for material

defects in Clause 1 of this section do not apply to damages resulting from grossly negligent or intentional breach of duties by the seller, their legal representative, or their vicarious agents, as well as in cases of injury to life, body, or health.

3. If the seller is liable for damages caused by slight negligence in accordance with statutory provisions, their liability is limited: Liability only exists for breaches of material contractual obligations, i.e., those obligations that the purchase contract imposes on the seller according to its content and purpose or whose fulfillment is essential for the proper execution of the purchase contract and on which the buyer regularly relies and can rely. This liability is limited to the typically foreseeable damage at the time of contract conclusion.  
The personal liability of the seller's legal representatives, vicarious agents, and employees for damages caused by slight negligence is excluded.  
The limitations of liability and exclusions of liability stated above apply accordingly to this provision.
4. Regardless of any fault on the part of the seller, the seller's liability remains unaffected in cases of fraudulent concealment of a defect, assumption of a guarantee, or assumption of a procurement risk and under the Product Liability Act.
5. In the case of rectification of defects, the following applies:
  - a) The buyer must assert claims for material defects against the seller; in the case of oral notifications of claims, the buyer must be provided with a written confirmation of receipt.
  - b) Replaced parts become the property of the seller.

## VIII. Liability for Other Damages

1. Other claims of the customer not governed by Section VII, „Liability for Material Defects,“ expire within the regular statutory limitation period.
2. Liability for delivery delays is conclusively regulated in Section III, „Delivery and Delivery Delays.“ For other claims for damages against the seller, the provisions in Section VII, „Liability for Material Defects,“ Clause 3 and 4 apply accordingly.

## IX. Jurisdiction/Applicable Law

1. The exclusive place of jurisdiction for all present and future claims arising from the business relationship with merchants, including claims based on bills of exchange and checks, is the seller's place of business.
2. The same place of jurisdiction applies if the buyer does not have a general place of jurisdiction within the country, has relocated their domicile or habitual residence outside the country after the conclusion of the contract, or their domicile or habitual residence is not known at the time of filing the lawsuit. In all other cases, the buyer's domicile is considered the place of jurisdiction for claims brought by the seller against the buyer.
3. These terms of sale and all legal relationships arising from them are exclusively subject to the laws of the Federal Republic of Germany, excluding the United Nations Convention on Contracts for the International Sale of Goods dated 11 April 1980 (CISG).

## X. Notice in accordance with Section 36 of the Consumer Dispute Resolution Act (VSBG)

Notice in accordance with Section 36 of the Consumer Dispute Resolution Act (VSBG) The seller will not participate in a dispute resolution procedure before a consumer arbitration board within the meaning of the VSBG and is not obliged to do so.

## INDEX A-Z

Accessories .....	399
Additional hazardous material pumps .....	297
Additional storage .....	384
Additional tools .....	247
Basket stretcher .....	200
Battery test & charging system .....	364
Binding agents .....	306
Books .....	403
Boots .....	330
Chainsaws Husqvarna .....	165
Chainsaws Stihl .....	167
Charging devices .....	366
Children .....	397
Clothing .....	404
Compressed-air cylinders .....	273
Containment tanks .....	298
Current-carrying equipment .....	88
Decontamination equipment .....	303
Defibrillators .....	214
Document case Magirus .....	405
Dose rate meter .....	292
Drone Magirus .....	76
Elastics .....	378
<b>ENVIRONMENTAL EQUIPMENT .....</b>	<b>287</b>
Escape & rescue devices .....	278
Extinguishing module/portable pumps .....	359
Fan LEADER BatFan 3 Li+ .....	120
Fire blanket – passenger cars LEADER STOP .....	61
Fire blankets .....	60
Fire extinguisher .....	56
Fire extinguisher Magirus .....	53
<b>FIRE EXTINGUISHING EQUIPMENT .....</b>	<b>47</b>
<b>FIRE STATION EQUIPMENT .....</b>	<b>363</b>
Firefighter clothing .....	312
Firefighter helmet Magirus Protectus P1 .....	332
Firefighter helmets .....	342
First-aid boxes & backpacks .....	210
<b>FITTINGS &amp; HOSES .....</b>	<b>11</b>
Floodlights .....	107
Foam fittings .....	62
Foaming agents .....	64
Gas detection technology .....	288
Generator Instagrid .....	81
Generators Magirus .....	80
Generator MSE 14 Super Silent Plus .....	78
Generators Eisemann .....	85



## INDEX A-Z

Generators Endress.....	82
Gloves .....	327
Hand lamps .....	94
Hazardous material pumps/Diaphragm pump .....	296
Hazardous materials fittings.....	293
Heliskid .....	356
Helmets .....	338
High pressure fire-extinguishing devices.....	50
Hose carrying basket flexattack® „Waldbrand“ .....	20
Hose carrying baskets .....	21
Hose compartments.....	372
Hose integration system Easy-Fix.....	18
Hoses .....	16
Hydraulic rescue equipment Lukas.....	128
Hydraulic rescue equipment Weber.....	143
Hygiene station MAGIRUS .....	263
Illuminators.....	105
Jumping cushions .....	203
Ladders MUNK Rettungstechnik .....	186
Lashing straps.....	244
Latches.....	383
Magirus M-Eye Drone .....	74
<b>MERCHANDISE .....</b>	<b>393</b>
Model „Ulmer Leiter“ .....	394
Models .....	395
Monitors .....	43
Mounting brackets .....	382
<b>MOUNTS/STORAGE .....</b>	<b>371</b>
Nozzle Magirus QC (Quick Connect) .....	34
Nozzles .....	37
Nozzles Magirus.....	35
One-person hose reels.....	255
Our high-performance portable pump Magirus Fire 1500 .....	68
Our Magirus ServiceLine portfolio .....	368
<b>PERSONAL PROTECTIVE EQUIPMENT (PPE).....</b>	<b>311</b>
Plasma cutters .....	179
Pneumatic rescue equipment Vetter.....	152
Portable pumps .....	70
Portable water tanks .....	358
Power tools .....	239
Pressure hoses .....	12
Privacy screen/Sheltering tent .....	215
Profile technology .....	392
Protective clothing .....	321

## INDEX A-Z

Protective equipment .....	347
Pull & lifting equipment.....	241
Pumps Mast .....	180
Recover-E-Bag.....	59
Rescue and working platforms .....	189
Respiratory masks.....	271
Respiratory monitoring.....	276
<b>RESPIRATORY PROTECTION.....</b>	<b>265</b>
Roll containers.....	261
Ropes/ Rope bags .....	198
Round & webbing slings.....	242
SCBA systems .....	266
Scoop stretchers & vacuum mattresses .....	207
Separating tools .....	174
Shackles .....	246
Slings/Rescue blankets.....	204
Small parts.....	379
Smoke shutters .....	127
Snow chains.....	254
Spine boards .....	208
Stirrup & extinguishing backpack pumps and fire buckets .....	48
Storage for hose carrying baskets.....	374
Straps .....	340
Straps .....	375
Stretcher rescue lanyard .....	193
Stretchers .....	206
<b>TECHNICAL EQUIPMENT.....</b>	<b>73</b>
Telescopic slide aluminium .....	390
Thermal imaging cameras .....	283
Thermal imaging cameras Magirus .....	280
Tool boxes and cases .....	233
Tool set Fall arrest/Pulley.....	191
Tools .....	218
Traffic cones & folding signs .....	116
Transfer pumps.....	67
Vacuum cleaners.....	184
Vallfirest heavy-load carrying system .....	49
Ventilation equipment .....	122
Ventilation equipment Magirus .....	121
Warning & barrier material .....	118
Warning lights .....	111
Water-conducting fittings.....	24
Wildland fire gear .....	349
<b>WILDLAND FIREFIGHTING EQUIPMENT .....</b>	<b>341</b>
Wildland firefighting tools .....	354

## Batteries

In connection with the sale of batteries or the delivery of devices containing batteries, the seller is obligated to inform you of the following: As an end user, you are legally obliged to return used batteries. You can return batteries to the seller or at designated collection points (e.g., municipal collection points or retail stores) free of charge after use. You can also send the batteries back to the seller by mail. The seller will reimburse you for the postage of returning your old battery.

The symbols depicted on the batteries have the following meanings:



= Battery must not be disposed of in household waste

Pb = Battery contains more than 0.004% lead by weight

Cd = Battery contains more than 0.002% cadmium by weight

Hg = Battery contains more than 0.0005% mercury by weight

